



# **GAS INSTALLATION & SERVICE STANDARDS**

May 2026, Rev. 0

# Table of Contents

REVISION LOG .....	4
<b>SECTION 1: Introduction</b> .....	5
1.1 Purpose .....	5
1.2 Service Territory.....	5
1.3 Contact Information.....	5
1.4 Abbreviations.....	6
1.5 Definitions.....	7
<b>SECTION 2: Pipeline Facilities Overview</b> .....	10
<b>SECTION 3: VGS Service and Energy Efficiency Programs</b> .....	11
<b>3.1 Service Department</b> .....	11
<b>3.2 Energy Efficiency Programs</b> .....	11
<b>SECTION 4: DigSafe® &amp; Cross Bores</b> .....	12
4.1 DigSafe® .....	12
4.2 Cross Bores.....	12
<b>SECTION 5: Laws &amp; Governing Codes</b> .....	14
5.1 Federal .....	14
5.2 State .....	14
5.3 City & County .....	14
<b>SECTION 6: Right-of-Way Agreements, Land Use, &amp; Encroachments</b> .....	15
6.1 Right-of-Way Agreements.....	15
6.2 Land Use Information.....	15
6.3 Encroachments .....	16
<b>SECTION 7: General Requirements for Developers, Contractors &amp; Builders</b> .....	18
7.1 General Application and Scheduling Requirements .....	18
7.2 Site Plans and Site Preparation .....	18
<b>SECTION 8: Gas Mains &amp; Service Lines</b> .....	22
8.1 Gas Mains.....	22
8.2 Gas Service Lines .....	22
<b>SECTION 9: Meters, Regulators, Piping, Roofs, and Barricades</b> .....	26
9.1 Meters .....	26
9.2 Regulators .....	27
9.3 Piping, Tubing and Connectors .....	29
<b>9.3.1 Piping</b> .....	29
<b>9.3.2 Corrugated Stainless Steel Tubing (CSST)</b> .....	29
<b>9.3.3 Flexible Appliance Connectors</b> .....	30
9.4 Roofs for Meters/Regulators.....	30
9.5 Barricades/Barriers .....	30
9.6 Gas Meter Recess.....	33

9.7	Gas Meter Enclosures .....	34
9.8	Elevated Gas Pressure .....	36
9.9	Pressure Tests .....	36
<b>SECTION 10: Working in the Vicinity of Gas Lines .....</b>		<b>37</b>
<b>SECTION 11: Infill Services &amp; Natural Gas Service Line Installation .....</b>		<b>39</b>
11.1	Infill Services .....	39
11.2	Natural Gas Service Line Installation.....	39
<b>SECTION 12: Fuel Lines, Pool Heaters &amp; Underground Piping .....</b>		<b>41</b>
12.1	Getting Started:.....	41
12.2	Next Steps - Customer & Contractor Responsibilities.....	41
12.3	Final Steps.....	42
<b>SECTION 13: Natural Gas Service to Mobile Homes and Mobile Home Parks.....</b>		<b>43</b>
13.1	Feasibility .....	43
13.2	Natural Gas Distribution Main .....	43
13.3	Natural Gas Service Lines.....	43
13.4	Conversion of Appliances .....	44
<b>SECTION 14: Customer Dig Guidelines .....</b>		<b>46</b>
14.1	Permits .....	46
14.2	Easements .....	46
14.3	Digging within a Public Right of Way .....	46
14.4	Dig Safe .....	46
14.5	Scheduling of Construction.....	46
14.6	Construction .....	47
<b>Appendix A: Meter Diagrams .....</b>		<b>49</b>
<b>Appendix B: VGS Pressure Test Form.....</b>		<b>58</b>

## REVISION LOG

Revision Date	Approver	Changes
2026	Chris LeForce	Revised 4.1, DigSafe for 72 hour advance notice. Added information to Section 9.3, Piping, Tubing and Connectors. Added meter/regulator roof specifications.
April 30, 2025	Chris LeForce	Revised Section 9: Added information required for elevated pressure requests and pressure testing; moved meter diagrams to new Appendix A and added Appendix B for pressure test form.
May 22, 2024	Chris LeForce	Revisions to VGS contact information, Section 3 updated for VGS current offerings, edits to Section 6.2 ROW Land Use, added heat pumps and solar electrical panels as needing 3-ft distance from VGS regulators in Section 9.1 Regulators, updates to Section 9.4 Barricades/Barriers, and in Section 10 Working in the Vicinity of Gas lines, added criteria for exposed gas pipe support.
April 28, 2023	Chris LeForce	Administrative updates to Section 5; revisions to section 9.3 Piping, Tubing and Connectors, 9.4 Barricades/Barriers; 14.6 Construction – added information to Customer Dig requirements.
Dec. 4, 2022	John St.Hilaire	Revised Section 14.3 Digging within a Public ROW to require approval by VGS VP of Operations.
April 29, 2022	John St.Hilaire	Added CSST and flexible appliance tubing to chapter on Regulators, Meters, Piping & Barricades and updated; updated drawings with PE stamp version.
March 11, 2021	John St.Hilaire	Added Exactix© online ticket system link for Dig-Safe. Updated definitions. Updated <i>Energy Efficiency Programs</i> statement. Added functioning links to Section 4. Updated section 8.1a to include meters. Updated 8.4a, removing requirement to paint barricades yellow, and added general rule to install barricades 4-feet from building exteriors, with 12-inch clearance. In 13.3, removed “Menard & Sons” and “Champlain Construction” from qualified excavation contractor table.
Prior to 2020		Contact Safety & Compliance team for past revision history.

## SECTION 1: Introduction

### 1.1 Purpose

This handbook outlines the standards and procedures to be followed when working near or around VGS (Vermont Gas Systems, Inc.) facilities or when requesting the installation of natural gas facilities. The handbook is intended for use by city/state planners, engineers, land surveyors, landowners, customers, developers, builders, and other private contractors. When installing new natural gas facilities or working in the vicinity of facilities, project delays can be avoided, and safe practices can be attained if VGS is included in the initial planning stages.

The handbook is designed to make you aware of the most common standards and procedures VGS typically requires for installation and to protect its facilities. This handbook is intended to be a guideline and is not a complete set of rules governing natural gas installations. Each proposed development, project, or activity, however, may require a case specific evaluation by a qualified VGS representative.

VGS feels that compliance with this manual will ensure a quality installation in a timely manner. If you have further questions or need assistance, please contact the VGS office at (802) 863-4511 or toll free at 1-800-639-2112.

### 1.2 Service Territory

Maps showing our service territory are available at: <https://vgsvt.com/service/coverage-map/>

### 1.3 Contact Information

Gas Leaks and/or Odor Complaints:	1-800-639-8081 <b>(DO NOT USE E-MAIL)</b>
General Questions, Phone:	1-800-639-2112
General Questions, E-mail:	<a href="mailto:customerservice@vermontgas.com">customerservice@vermontgas.com</a>
Energy Efficiency, E-mail:	<a href="mailto:efficiency@vermontgas.com">efficiency@vermontgas.com</a>
Company Web Address:	<a href="http://vgsvt.com">vgsvt.com</a>
Office Address:	85 Swift Street South Burlington, Vermont 05403

**Dig-Safe® (“CALL BEFORE YOU DIG”): 811**

Dig-Safe® Web Address: [www.digsafe.com](http://www.digsafe.com)

To request a ticket online, visit <https://exactix.digsafe.com/login>.

## INTRODUCTION

---

For answers to your questions about installations call:

New Line Requests:	(802) 951-0351 Sale@vermontgas.com
Customer Service:	(802) 863-4511 CustomerService@vermontgas.com
Right-of-Way, Easements:	(802) 951-0337 RSales@vermontgas.com
Construction (sleeve designs, meter location, gas pipeline design, customer dig, installations, scheduling):	(802) 863-4511 Construction@vermontgas.com

### 1.4 Abbreviations

AGA	American Gas Association
API	American Petroleum Institute
ANSI	American National Standards Institute
ASME	American Society of Professional Engineers
ASTM	American Society for Testing and Materials
BTU	British Thermal Unit
BTUH	British Thermal Unit per Hour
CCF	Hundred Cubic Feet
CF	Cubic Foot
CFH	Cubic Foot per Hour
DOT	Department of Transportation
EFV	Excess Flow Valve
HDD	Horizontal Directional Drill
IPS	Inches per second
MBTUH	Thousand British Thermal Unit per Hour
MCF	Thousand Cubic Foot
MCFH	Thousand Cubic Foot per Hour
MMBTUH	One Million British Thermal Unit per Hour
OQ	Operator Qualification
PHMSA	Pipeline & Hazardous Materials Safety Administration
PSIG	Pressure in Pounds per Square Inch Gauge
ROW	Right-of-Way
WC	Pressure in Inches of Water Column

### 1.5 Definitions

**Appliance:** Any device that utilizes natural gas as a fuel or raw material to produce light, heat, power, steam, refrigeration or air conditioning.

**British Thermal Unit (BTU):** The quantity of heat required to raise the temperature of one pound of water one degree Fahrenheit.

**Building:** Shall mean a structure that stands alone or is cut off from adjoining structures by firewalls, as defined by the municipality or the authority having jurisdiction, with no openings or penetrations and doorways to be protected by approved fire doors.

**Casing:** Steel conduit used to protect steel transmission lines and steel or plastic distribution mains in certain situations. Casing requirements will be based on API recommended practice RP-1102 and the design must be approved by the VGS Engineering Department.

**Combustible Material:** Any material such as wood, paper, sheet rock, fibers or other materials that will smolder, ignite or burn when adjacent to or in contact with heat producing appliances, vent connectors, gas vents, chimneys, or hot water pipes.

**Combustion Air:** Air supplied to an appliance specifically for the combustion of fuel.

**Cubic Foot of Gas:** The amount of gas that occupies one cubic foot of space when at a temperature of 60 degrees Fahrenheit, and under pressure equivalent to that of 29.92 inches of mercury.

**Curb Valve:** A shut-off valve in a gas service line, usually located between the curb and a customer's building/premise.

**Customer Dig:** Upon VGS approval, the customer may be permitted, at their expense, to trench and backfill within the exact specifications provided by VGS.

**Customer Owned Piping:** The piping that is installed after the company's meter set that connects the customer's appliances and equipment to the gas supply. Customer Owned Fuel lines are the responsibility of the customer.

**Department of Transportation (DOT):** The federal regulatory agency that governs gas pipeline safety, transportation of hazardous materials, and administers regulations related to highway rights-of-way.

**Developer:** Person or company that invests in and develops real estate, especially by subdividing the land into home sites and building houses. **In this document this also includes site contractors and builders.**

**Dig-in:** Damage caused to VGS pipelines and/or facilities by digging into them during excavation activities, either by hand or mechanized equipment.

**Easement:** A document conveying legal interest to use land, from its owner to another party, for a specified purpose. Easements provide VGS the legal right to access property, install, maintain, replace, and abandon natural gas pipelines or facilities on privately owned lands that are outside the public Right-of-Way.

## INTRODUCTION

---

**Excess Flow Valve:** An excess flow valve (sometimes called an EFV) is a device that is installed in a natural gas piping system that restricts gas released in the event the pipe is severed downstream of the EFV.

**Gas Main or Distribution Main:** The piping system owned by the company that is used for the distribution of gas that is (a) located within the limits of any public highway or on a private right of way or (b) is used to supply gas to two or more gas services.

**Greenbelt:** That area of a public street located between the roadway edge and the sidewalk, or, if no sidewalk exists, between the roadway edge and the adjacent property line.

**HDPE:** High density polyethylene

**Infill Service:** A service that is installed off a preexisting distribution main.

**Input Rating:** The gas burning capacity of an appliance in BTU/Hr. as specified by the manufacturer.

**Loads-Connected:** The sum of the rated BTU/Hr. input of all connected gas equipment. May also be expressed in cubic feet per hour.

**Locator Wire:** A wire installed with all plastic pipe (including mains and services) to ensure being able to readily locate the buried piping in the future.

**Make Up Air:** The volume of air, either outside or inside, that is supplied to a space to replace air consumed by the gas burning appliances, exhausted or otherwise removed from the space.

**Mechanical Exhaust Appliance:** An appliance with a venting system designed to remove flue or vent gases by mechanical means utilizing induced draft under non positive pressure or forced draft under positive pressure.

**Meter:** An instrument installed by the company to measure the volume of Natural Gas delivered to a customer.

**Pipe:** Any pipe or tubing used in the transportation of gas.

**Primary Air:** The combustion air that mixes with the gas before it reaches the burner.

**Qualified Installer:** An individual who is qualified by the company or an authority acceptable to the company.

**Regulator:** Control valve in a pipe system that reduces and maintains a required gas pressure.

**Right-of-Way (ROW):** An agreement by which a property owner grants permission to another party to use a portion of his or her land for a specific purpose.

**Secondary Air:** The air externally supplied to the flame at the point of combustion.

**Service Line:** A part of the pipeline distribution system that transports gas from the gas main to the building/premise.

**Service Riser:** A vertical pipe, adjacent to a customer's building/premise that runs from the service line to the customer's meter.

## INTRODUCTION

---

**Sleeve:** Non-metallic conduit that may be installed prior to installation of gas pipe at road or ROW crossings. Sleeves are not load bearing, have no pressure and shall only be used to insert gas carrier pipe and/or locator wire.

**Valve Box:** A vertical tube that is capped at ground level and usually located near the street. Its purpose is to protect the access point to the underground shut-off valves.

## SECTION 2: Pipeline Facilities Overview

VGS delivers clean, affordable natural gas to over 55,000 families and businesses in Chittenden, Franklin and Addison counties. VGS owns and operates over 118 miles of transmission pipeline with over 70 million cubic feet per day at peak capacity. The transmission line currently extends from the Canadian Border in Highgate, VT to Middlebury, VT. The transmission operation includes high-pressure steel pipeline ranging in diameter from four(4-inch) to sixteen (16-inch) inches, meter and regulating stations or gate stations, odorization equipment, mainline valves, cathodic protection equipment, and other related facilities. Gate stations reduce the pressure in the transmission line and feed into the distribution main network.

VGS owns and operates over 880 miles of distribution main which consists of both high-density polyethylene plastic (HDPE) pipe and cathodically protected steel ranging in diameter from 3/4-inch to 10-inches. VGS gas service lines are both HDPE pipe and cathodically protected steel and range in diameter from 1/2-inch to 4-inches. A service to a residential home typically is 1/2-inch or 3/4-inch HDPE.

## **SECTION 3: VGS Service and Energy Efficiency Programs**

VGS is committed to advancing a decarbonized energy future, with energy efficiency serving as a foundational component in achieving Vermont's climate and energy goals. VGS has delivered energy efficiency programs to residential and commercial customers since 1992 and was designated as an Energy Efficiency Utility ("EEU") by the Vermont Public Utility Commission in 2016.

VGS is committed to equitable program access and participation across all customer segments. Programs are designed to deliver energy savings and customer value while improving building performance, occupant comfort, and long-term affordability. In addition to reducing greenhouse gas emissions, energy efficiency investments contribute to improved health and safety outcomes, enhanced productivity in commercial settings, and overall economic benefits for Vermont communities.

### **3.1 Service Department**

VGS offers a full suite of services relating to home heating equipment and appliances.

- Lease or purchase home heating and water heating equipment, gas-fired and electric heat pump
- Service plans including with or without annual inspections
- A team of service technicians who install, service and repair natural gas and electric heat pump equipment and appliances.
- Emergency response 24/7 for leak or gas odor calls (free service)

### **3.2 Energy Efficiency Programs**

VGS provides a comprehensive suite of energy efficiency services, including technical assistance, rebates, and guidance to support the installation of cost-effective, high-efficiency equipment and building performance improvements. These offerings include measures such as high-efficiency heating systems, weatherization (including insulation and air sealing), and emerging technologies that reduce energy consumption and emissions. Financing options, including zero- and low-interest loans offered in partnership with Green Mountain Credit Union, are available to help customers overcome upfront cost barriers.

## SECTION 4: DigSafe® & Cross Bores

### 4.1 DigSafe®

Vermont law requires that anyone planning to dig (includes excavations, planting trees and bushes, and installing signs) call DigSafe® (811) seventy-two (72) hours in advance of your planned activity. DigSafe® is a free service and requires gas, electric and telecommunication utilities to respond (either mark out their underground lines with paint or flagging or note that they have no buried lines in the area of planned work). You must pre-mark the approximate area where you plan to dig.

Most water and sewer departments/companies do not belong to DigSafe®. You may need to contact these parties directly for facility locating.

Dial **811** or visit [Digsafe.com](http://Digsafe.com) to submit a request.

1. VGS will not be responsible for underground utilities which have not been or cannot be located and marked either by the respective utilities or the customer or developer desiring natural gas.
2. If VGS damages unmarked underground facilities, it will be the responsibility of the customer or developer to pay for the cost of repair.
3. Unmarked private utilities will be the responsibility of the customer or developer.

**IMPORTANT NOTICE: If you damage a gas line and it is leaking, state and federal law requires you to call 911 first - then call VGS.**

### 4.2 Cross Bores

*Description:* A Cross Bore occurs when a utility line intrudes into another utility line and is most commonly associated with utilities crossing sewer lines. Cross bores occur during the installation process of a utility such as electric, cable/internet, water, and natural gas. Cross Bores primarily occur when the utility is installed using boring techniques such as Horizontal Directional Drill (HDD) or pneumatic drilling.

*Danger:* Cross Bores present serious risks to contractors, homeowners, and the community. Clearing sewer blockages caused by Cross Bores can be especially dangerous. It is imperative to identify the cause of a sewer blockage prior to clearing the blockage. There are documented instances of people clearing cross bored sewer lines without prior inspection, rupturing a utility line and causing injury, property damage, and even death.

*Prevention:* Contact Dig Safe® prior to any planned installations or digging. However, be aware that Vermont sewer companies are not required to identify the sewer line locations. When sewer line location and depth are unknown, open trenching techniques will be utilized for gas installation. If all utilities cannot be located, installation should be done using open trench methods of construction.

## DIGSAFE & CROSS BORES

---

**Note:** A sewer contractor can be contacted to attempt to locate sewer lines prior to construction.

It is necessary to investigate any sewer blockages that occur prior to attempting to clear the blockage. If unable to visually verify that the blockage has not been caused by a cross bored utility **Do Not** attempt to clear the blockage with mechanical equipment. Call Dig Safe® and request an emergency locate for utility lines. If it is shown that the gas utility crosses the known path of the sewer line, contact VGS. A VGS technician will provide assistance to correct the problem.

## SECTION 5: Laws & Governing Codes

Applicable laws and codes are listed below. If there is a conflict of rules, the company will make a final decision applicable to the situation.

### 5.1 Federal

**ANSI Z-223.1/NFPA 54 National Fuel Gas Code (applies to customer owned piping)**

<https://www.nfpa.org/Codes-and-Standards/All-Codes-and-Standards/Free-access>

**Department of Transportation Title 49 CFR Part 192**

[49 CFR 192 - Transportation of Natural and Other Gas by Pipeline](#)

### 5.2 State

**Vermont State Statute Title 30**

<https://legislature.vermont.gov/statutes/title/30>

**Vermont Public Utility Commission Rules**

<https://puc.vermont.gov/about-us/statutes-and-rules/current-rules-and-general-orders>

**Vermont Public Utility Commission Approved Tariffs**

<https://vgsvt.com/service/rates/tariffs/>

### 5.3 City & County

Local permit rules vary from town to town and city to city. Any questions about local excavation permitting processes may be directed to the VGS Engineering and Construction Departments at (802) 863-4511.

## **SECTION 6: Right-of-Way Agreements, Land Use, & Encroachments**

### **6.1 Right-of-Way Agreements**

A right-of-way agreement is an agreement by which a property owner grants permission to another party to use a portion of his or her land for a specific purpose. VGS works with landowners to secure a deed of easement, which outlines the rights of the parties and terms of the agreement. The right-of-way gives VGS the right to construct, operate, and maintain its pipeline and related facilities, along with other rights beneficial to VGS for the safe and continued operations of its pipelines. VGS also has the right of ingress and egress over the pipeline corridor. The right-of-way agreement or easement grants VGS an interest in the property, and the easement is recorded in the appropriate municipal land records. A deed of easement is a legal document. If the land is transferred, the rights and responsibilities under the terms of the easement pass on to the new owner.

Most of VGS's existing pipeline easements and rights were acquired through right-of-way agreements granting VGS the right to construct, operate, maintain, repair, modify, alter, protect, clear obstructions, change the size of, remove, replace, and access a pipeline, or pipelines, within the easement area.

In cases of new installations, VGS may require an easement or right-of-way, which is needed prior to installation of distribution mains and/or service lines. Our sales representative can supply you with the required forms to initiate the easement documentation. Please provide us with the name of the current property owner as soon as possible. If you have any questions or concerns, please contact our Right-of-Way Department at (802) 863-4511 or email [rowcorridor@vermontgas.com](mailto:rowcorridor@vermontgas.com).

### **6.2 Land Use Information**

Under the deed of easement, the landowner may use their land as they wish provided it does not interfere with the rights granted to VGS to maintain and operate our pipeline. For safety purposes, we require all landowners to notify VGS prior to any work on the right-of-way. Certain work on the premises may unduly interfere with the safety of our pipeline. VGS cannot permit such work. We have summarized some of these situations below:

1. No trees shall be planted within the confines of the right-of-way. We consider trees as those plants that grow to an excess of five (5-foot) feet in height at maturity. Taller trees inhibit access to the pipeline and their roots can damage the pipeline. Small shrubs or bushes less than five (5-foot) feet in height may be permitted to be located on VGS's right-of-way provided they are not planted within ten (10-foot) feet of the pipeline, or between the pipelines in a multiple line situation. In either of these cases, VGS can locate our pipelines for you. No permanent planting of any type within ten (10-foot) feet of the pipeline is allowed. Please note under the terms of the right-of-way agreement, VGS still reserves the right to remove any trees, shrubs or other obstructions, without compensation, that may interfere with the operation and

maintenance of its facilities. As such, it is in your best interest to consult with VGS prior to locating shrubs or bushes within the right-of-way area.

2. No earth shall be removed from the surface of the right-of-way, for such removal can expose the pipeline to damage. Small amounts of fill may be added with VGS's prior approval, provided it is clean fill, free of rocks, stumps, and debris. No water impoundment is allowed within VGS's right-of-way.
3. No structures shall be located on the right-of-way. This includes, but is not limited to houses, utility sheds, garages, swimming pools, house trailers, wells, sewer systems, etc. VGS must be able to access and maintain the pipeline at all times. Permanent fences located across the right-of-way require prior written authorization from VGS. Such authorization shall include provisions to address VGS access, proper gates, locks, damage waiver, etc.. If you install a lock on the gate, VGS must have its own set of keys or the combination.
4. Underground utilities crossing VGS's pipeline shall be installed below the pipeline, with a minimum of 12 inches of vertical clearance and 36 inches of horizontal clearance so as not to interfere with the pipeline. Utilities include sewers, drain lines, water pipes, gas pipes, underground electric or telephone cables, communication and fiberoptic cables, etc. These facilities are not to be placed parallel to our pipeline within VGS's right-of-way. Septic systems shall not be built on VGS's right-of-way. All utility plans must be approved by VGS, prior to installation. VGS reserves the right to have an inspector onsite while work is being performed inside the right-of-way area.
5. No heavy equipment is to be moved across the right-of-way prior to notifying VGS.

Construction plans that affect VGS's rights-of-way, as outlined in paragraph four (4) and five (5) above, should be submitted for review and approval prior to the start of any construction project. Bringing us into the early planning stages of your project will help to avoid delays and additional costs.

### **6.3 Encroachments**

#### **Specifications and Requirements**

1. An encroachment agreement is required whenever a permanent installation (e.g., utility lines, pipelines, road crossings, above and below ground structures, sheds, swimming pools, trees, berm, shrubs, etc.) or intrusive temporary activity (e.g., construction, logging, mining, blasting, excavating) is approved to encroach into the right-of-way area.
2. The encroachment agreement must be executed by the landowner or party seeking to encroach and VGS prior to the proposed activity or installation.
3. All encroachment agreements covering permanent installations will be recorded in the appropriate municipal land records.
4. The encroachment agreements covering temporary encroachments will be recorded in the land records at the discretion of VGS.

## RIGHT-OF-WAY AGREEMENTS, LAND USE & ENCROACHMENTS

---

5. All encroachments require prior approval by VGS and may be denied or approved based on a case-by-case basis. Project scope and proximity to the pipeline will be considered in accepting or rejecting any proposed encroachment.
6. All encroachment agreements will be tailored to the specific permanent or temporary encroachment.
7. It is our desire and right to keep a clear right-of-way that can be used by our maintenance personnel.
8. VGS must be able to access the pipeline and other facilities along and within its rights-of-way across your property in order to properly maintain and operate our facilities in accordance with the United States Department of Transportation regulations.

VGS understands its responsibilities and will exercise its rights with a minimum of inconvenience to you. Your safety and the safety of the public are our first consideration and top priority. We appreciate your cooperation.

**\*Remember to call DigSafe® at 811 prior to any digging, demolition, blasting or excavation activity.** This is a free public service and is the law to call before you dig.

# GENERAL REQUIREMENTS FOR DEVELOPERS, CONTRACTORS & BUILDERS

---

## SECTION 7: General Requirements for Developers, Contractors & Builders

### 7.1 General Application and Scheduling Requirements

1. Individual service applications should be submitted at least **60** days before the required installation date. In some instances, the exact requested installation date may not be known when submitting the original application. In these cases, the installation request must be made to the VGS sales representative at **least thirty (30) days in advance.**
2. VGS will provide excavation work during its normal construction year, which typically runs from May 1<sup>st</sup> to November 15<sup>th</sup>, weather permitting. Excavation work outside of these dates is primarily limited to maintenance of our existing system. Any excavation work outside of these dates, including road crossings, will need to be performed by your excavating contractor (subject to local permitting). (See Section 14, Customer Dig Guidelines.)
3. Certain permits may affect the schedule and are not in the control of VGS.

### 7.2 Site Plans and Site Preparation

#### Plans

1. VGS will need a reproducible site plan along with other pertinent drawings, and a copy of the CAD file (.DGN, .DWG or .DXF format) of the site plan and utility plan.
2. Prior to submitting your site and/or utilities plan to VGS, please contact the Engineering Department. They will inform you as to the proper location of gas mains and service lines to be shown on your drawings.
3. Appendix A contains diagrams of typical single and multiple meter sets to help you understand sizing and configurations so you can choose a proper location for customer-owned fuel lines. Proposed meter locations must be submitted with your site drawings.

#### Ledge

1. VGS does not generally excavate ledge unless it has been pre-approved.
2. If ledge is encountered, the developer shall remove the ledge that prohibits VGS from achieving proper depth.
3. In ledge area, a minimum of six inches (6-inch) of sand padding will be applied around the pipe with twelve inches (12-inch) on top of the pipe.
4. Only VGS-approved backfill material can be placed above the twelve inches (12-inch) of sand padding. **SAND FOR PADDING MUST BE FURNISHED BY THE DEVELOPER OR SITE CONTRACTOR.**

## GENERAL REQUIREMENTS FOR DEVELOPERS, CONTRACTORS & BUILDERS

---

### **Sleeves**

1. VGS requires that a sleeve be installed in specified locations for all distribution main and service line road crossings. VGS will open cut and backfill with the same material as unpaved gravel road base if you prefer.
2. VGS will supply the sleeve material and mark the desired locations on a site plan.
3. Developer is to install the sleeves outside of the driveway cut, favoring the side of the lot where the service is to be installed. If the service location cannot be determined at the time of the sleeve installation, sleeves should be installed near the center of the lot frontage away from the driveway curb cut.
4. It is the responsibility of the developers/contractors to supply field identification of the location of the sleeves.
5. If the sleeves are unusable or cannot be located, it will be the developers' responsibility to install a new sleeve, dig a trench or have the service drilled (if scheduling allows) at the developer's cost.
6. Sleeves shall be installed at a depth of three feet (3-foot) minimum below finish grade not to exceed a maximum of four feet (4-foot). Any deviation from these depths will need VGS' Operations Department approval.
7. Sleeves shall not be installed within twenty (20-foot) feet of any building or structure.
8. A sketch of a typical sleeve installation is enclosed (See Figure 7-1).

### **Site Preparation**

9. If site conditions do not make it obvious where the proposed gas main should be located, it is the responsibility of the developer to stake out the proposed gas main locations in the field. If the developer chooses not to do so all relocations will be at developers cost.
10. Stakes showing the centerline and final elevation of roads or streets shall be installed and maintained until construction is complete.
11. Finished grade elevations shall also be provided to assure proper depth of burial.
12. Foundations should be backfilled to within six inches (6-inch) of finish grade and the proposed service route should be free of obstructions and within six inches (6-inch) of finish grade before a service line is constructed. If not at finish grade, a horizontal mark must be made on the foundation showing the finished grade to allow for proper height of the gas meter.
13. To prevent future corrosion to the meter, care must be taken during subsequent grading to ensure the gas meter is not buried or in contact with the earth and the gas riser is not buried above the bury line. If finish grade results in either of these situations, contact VGS.
14. The developer, contractor or builder is responsible for supplying the sand used for padding the pipelines in "customer dig" applications.

## GENERAL REQUIREMENTS FOR DEVELOPERS, CONTRACTORS & BUILDERS

---

15. Developers, contractors and builders must notify VGS when the site will be ready. A three (3) week minimum lead-time is required for scheduling construction of distribution main or service lines. Please contact the Construction Team at [Construction@vermontgas.com](mailto:Construction@vermontgas.com) to schedule installation of gas mains and/or services. Please be sure you have submitted the application for service with the sales representative prior to calling to schedule the installation.

# GENERAL REQUIREMENTS FOR DEVELOPERS, CONTRACTORS & BUILDERS

## Figure 7-1 Road Crossing Sleeves

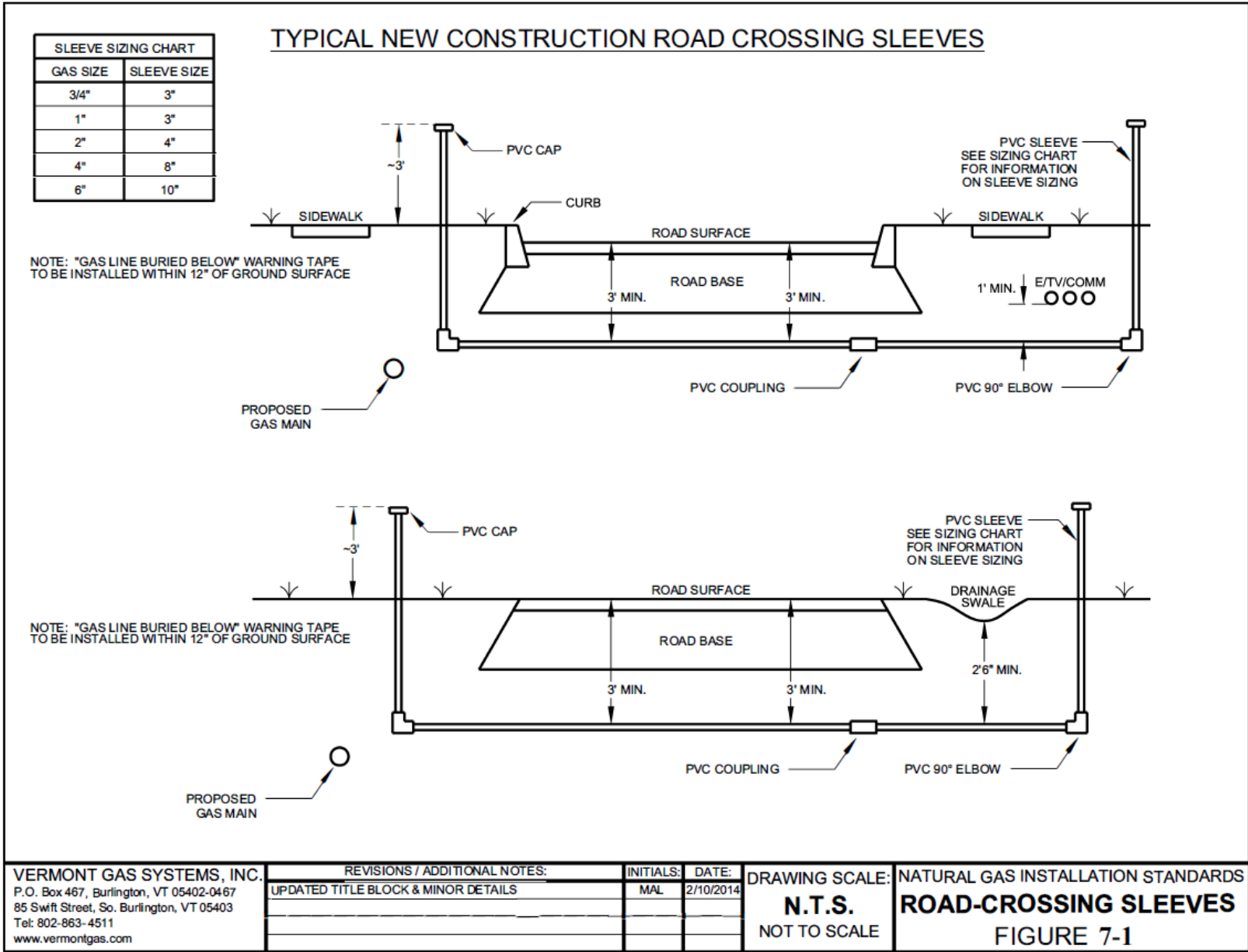

**VERMONT GAS SYSTEMS, INC.**  
 P.O. Box 467, Burlington, VT 05402-0467  
 85 Swift Street, So. Burlington, VT 05403  
 Tel: 802-863-4511  
 www.vermontgas.com

REVISIONS / ADDITIONAL NOTES:

UPDATED TITLE BLOCK & MINOR DETAILS	INITIALS:	DATE:
	MAL	2/10/2014

DRAWING SCALE: **N.T.S.**  
NOT TO SCALE

NATURAL GAS INSTALLATION STANDARDS  
**ROAD-CROSSING SLEEVES**  
 FIGURE 7-1

## **SECTION 8: Gas Mains & Service Lines**

VGS has committed to have all new gas facilities up to the outlet of the meter be installed to applicable PE-stamped drawings that have been reviewed and stamped by a licensed professional engineer. VGS completes this review prior to construction.

### **8.1 Gas Mains**

#### ***General Information***

1. The gas main pipe will be installed by VGS or a qualified VGS contractor.
2. No one other than a VGS employee or qualified VGS contractor shall ever work on or alter any part of the natural gas distribution facilities.
3. Gas main typically will be installed on the front side of buildings/houses between the edge of the road and the R.O.W./property line. Preferably the main will be in the greenbelt. Gas main will be installed parallel to the road edge.
4. No gas mains are to be installed behind buildings/houses unless approved by the VGS Operations Department.

#### ***Conditions for Installing Gas Facilities***

1. For direct buried gas lines and all other methods of construction, VGS requires a minimum three feet (3-ft) of horizontal separation from all other utilities. Other utilities may require as much as 10 feet (10-feet) of separation.
2. A minimum of twelve inches (12-inch) of vertical separation between gas lines and other utilities must be maintained at all times.
3. Locator wire for plastic gas lines shall not be in contact with any utility or underground structure.
4. VGS prefers that water mains, water laterals, sewers, and storm drains be installed prior to the installation of the gas mains and service lines.
5. The area in which the gas facilities are to be located should be made easily accessible and allow for safe working conditions.

### **8.2 Gas Service Lines**

#### ***General Information***

1. Gas services will be installed by VGS or a qualified VGS contractor.
2. No one other than a VGS employee or a qualified VGS contractor should ever work on or alter any part of the natural gas distribution facilities.
3. Service lines should be installed perpendicular from the main to the meter location. Service risers and meters will be located on either side or in front of a building/house. Except for corner buildings, services will be installed off the gas main on the street for which the address of the building/house is on. See diagram below for typical service design.

## GAS MAINS & SERVICE LINES

---

4. Corner buildings may have a service coming off either street with preference to the street which it is addressed on. The length of the service and whether a road crossing is required should also be considered.
5. Gas will be supplied to each building through a single service line or customer-owned fuel line unless otherwise approved by the VGS Operations Department.
6. Although not a preferred installation, for buildings with two (2) or more services, a Multiple Services sign will be installed at each riser. A sign with the location of the service risers will also be required at each riser on new service installations.
7. Service risers should be attached to the foundation with a support bracket where building foundation conditions allow.

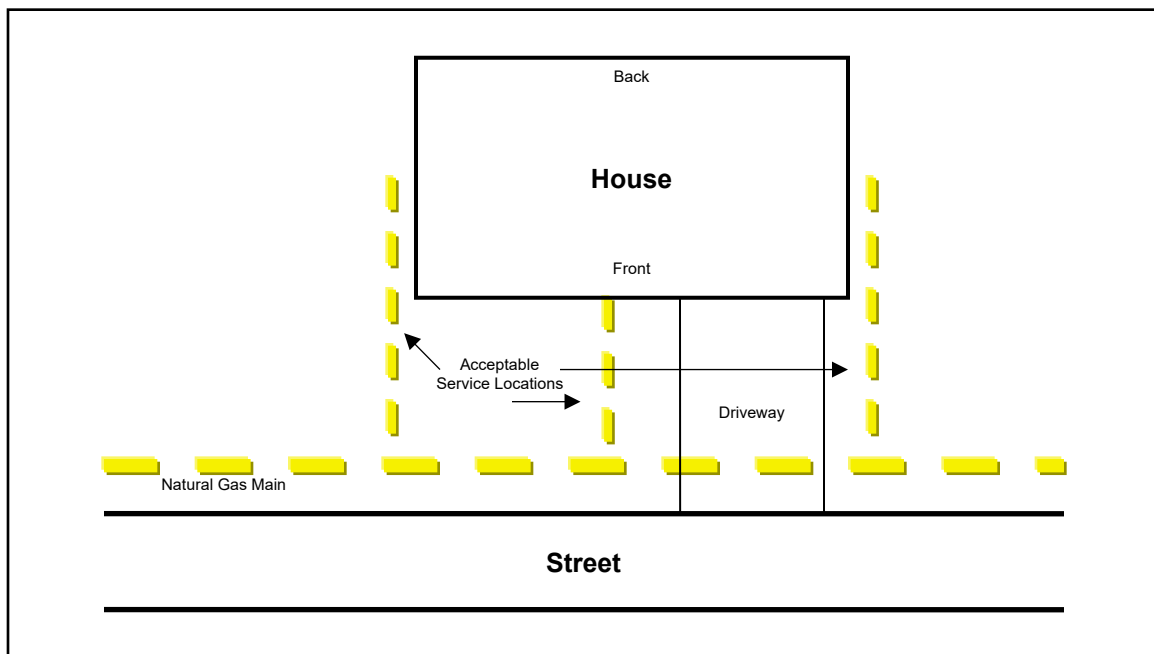

# REGULATORS, METERS, PIPING & BARRICADES

## Figure 8-1 Typical Trench Detail

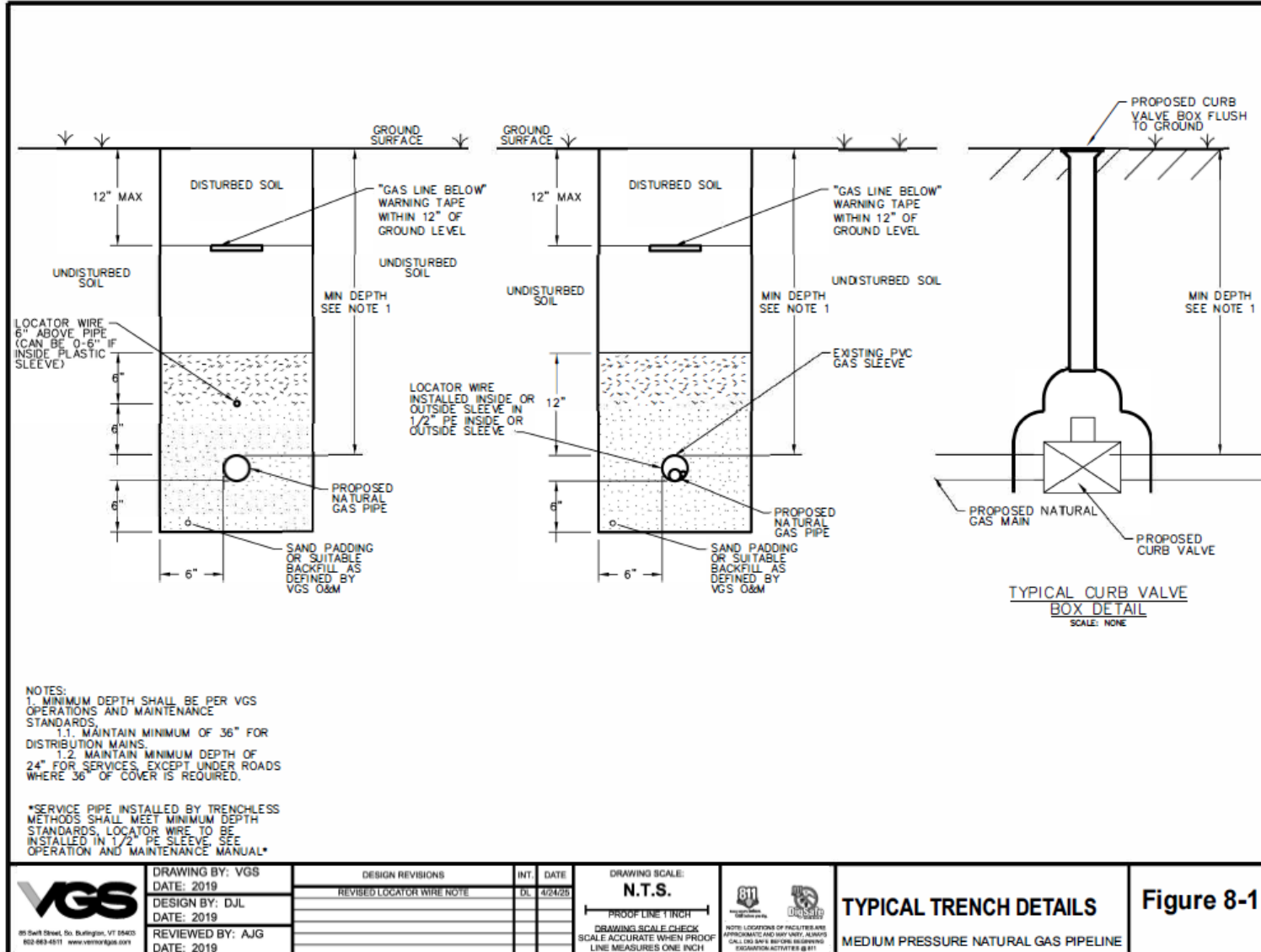
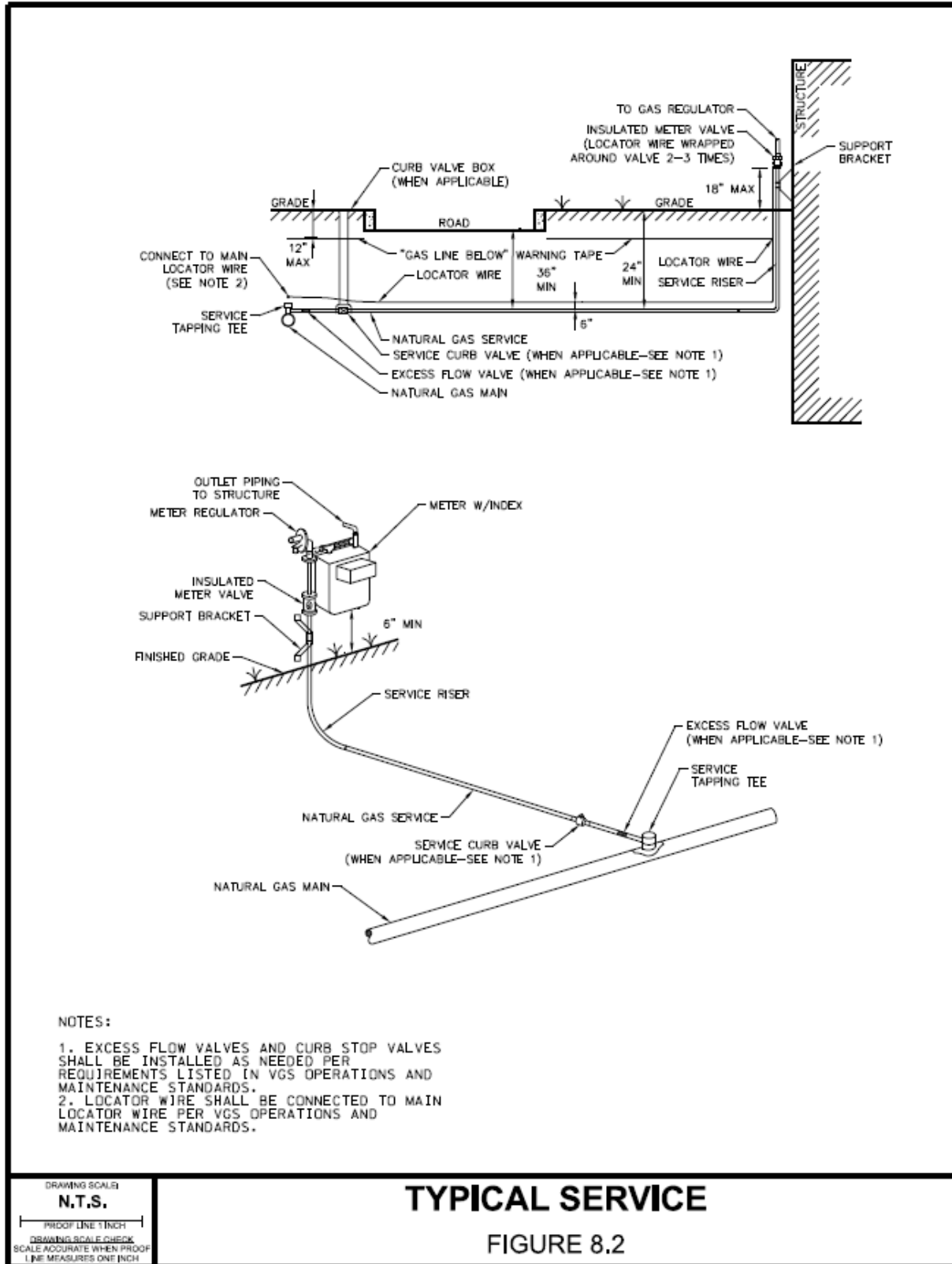

Figure 8-2 Typical Service



## SECTION 9: Meters, Regulators, Piping, Roofs, and Barricades

Installation and location of meters, regulators, and piping must comply with federal DOT pipeline regulations, NFPA and VGS requirements. See Appendix A for diagrams of meters and manifold configurations.

**NOTE:** The cost of relocating services after installation will be passed on to the contractor, developer or homeowner.

### 9.1 Meters

#### ***Specifications and Requirements:***

Gas meters should be located in the front or side of buildings and at the gable ends. The meter set needs to be accessible to the VGS and emergency responders at all times. In particular, avoid placement in the following areas.

- Avoid locating under the dripline of roof eaves where snow, ice or freezing water pose a threat. If such a location is unavoidable, install a protective roof above the meter and regulator set (see 9.4, Roofs).
- Avoid areas that could cause the meter set to be buried with snow during snow removal activities.
- Avoid locating under building soffits or awning windows – if a gas leak occurs, the gas could rise and migrate into the house.
- Avoid areas that are near vehicular traffic or parking areas. If this cannot be avoided, VGS will require the customer or builder to install barriers approved by VGS to protect the service and meter set at the customer's cost. See Section 9.5, Barricades/Barriers for specifications. **No meters will be turned on until above measures are satisfied.**
- No meters will be located on the back side of buildings unless no other feasible options exist and is approved by VGS Operations management.

Sizing and clearance for meter manifolds and outlet piping are provided in the tables below. Diagrams for different sized meter sets are provided in Appendix A. Please note the following:

- For the meter setup used in drawing D3, the 425 meter configuration used with an A.Y. McDonald 1-inch x 1-inch x 1-inch meter bar with offset reducer swivels can produce excess pressure drop.
- For the 630 meter configuration, use an A.Y. McDonald 1.25 inch meter bar (See Figure A-5).

Table 9-1: Sizing of Meters and Outlet Piping			
Gas Meter Sizing, 7-inch water column outlet pressure			Outlet Pipe Sizing
Size	Min. Flow	Max. Flow	
AC250	1	320	1-inch
Sensus R-275	1	320	1-inch
AL425	320	550	1-inch or 1.25-inch
AL630	550	900	1.25-inch
D1000	800	1,500	1.5-inch
2M	1,400	1,900	2-inch
3M	1,900	2,900	2-inch
5M	2,900	4,900	4-inch flange
7M	4,900	6,900	4-inch flange

Table 9-2: Support of Piping	
Steel Pipe, Nominal Size of Pipe (in.)	Spacing of Supports (ft.)
½	6
¾ or 1	8
1 ¼ or larger (horizontal)	10
1 ¼ or larger (vertical)	Every floor level

Table 9-3: Manifolds for AC250 & Sensus	
Manifolds	Inches to service from end of manifold
1 meter	14-inches
2 meter	34-inches
3 meter	50-inches
4 meter	66-inches
5 meter	82-inches

For SI units: 1 ft. = 0.305 m.

## 9.2 Regulators

### General Information

Gas pressure regulators will be set to deliver seven inches (7-inch) Water Column (W.C.) downstream of the meter unless a request for elevated gas pressure is made and approved by VGS (see section 9.4).

Regulators must be separated from ignition sources, air intakes, and vents to comply with federal regulations.

- a) A minimum of three feet (3-feet) of horizontal separation is required between the gas pressure regulator vent and potential sources of ignition. This includes heat pumps, solar electrical panels, electric meters, and A/C condensers and disconnects.

## REGULATORS, METERS, PIPING & BARRICADES

---

- b) A minimum of three feet (3-feet) of radial separation is required between gas pressure regulators vents and building openings; air-conditioning condensing units; and exhaust vents from heaters, water heaters, and dryers.
- c) A minimum ten feet (10-feet) of radial separation is required for gas pressure regulator vents from forced air intakes and make-up air units unless equipped with full lockup over-pressure shut-off. See Figure A-1 for a design depicting regulator location restrictions.
- d) Refer to figures in Appendix A for designs of typical single and multiple meter sets on to help you properly locate your fuel lines. Proposed meter locations must be submitted with your site drawings.

**Note:** the distances noted above are to provide separation between where the natural gas regulator vents and the potential ignition sources.

<b>Table 9-1: Regulators</b>						
Size	Body (inch)	Orifice (inch)	O.P.S.O.	Max. Flow scfh @ 25 psi	Max. Flow scfh @ 60 psi	Internal Relief & or OPSO
American 1213B	3/4	1/8	No	475	700	Full
American SR 113	3/4	1/8 x 3/16	No	500	1100	Full
Itron B42R	3/4	1/8 x3/16	No	550	1150	Full
Itron B42R	3/4 x 1 1/4	1/8x 3/16	No	550	1150	Full
American 1813C	1	1/8 x3/16	No	575	1100	Full
American 1843B2	1	3/16	Yes	1,250	2,400	partial w/ OPSO
American 1883B2	1	3/16	Yes	1,250	2,400	OPSO
American 1813B	2	1/4	No	2,500	4,500	Full
American 1843	2	1/2	Yes	9,050	17,400	partial w/ OPSO
American 1883	2	1/2	Yes	9,050	17,400	OPSO
Fisher CS400IR	1 1/2"	11/64"	NO	1,300	2,500	Full Relief
Fisher CS800IQ	2"	1/4"	NO	2,500	4,910	Full Relief
Fisher CS800IQ	2"	3/8"	NO	5,530	10,810	Full Relief

### 9.3 Piping, Tubing and Connectors

#### 9.3.1 Piping

- a) All customer owned piping, which is piping on the outlet side of the meter, must meet the NFPA 54 Natural Fuel Gas Code, as adopted by the State of Vermont, referenced in Section 5, Laws & Governing Codes.
- b) If stab fittings are used, VGS recommends the fittings have a double seal on the riser and that a soap test be performed on all connections during the pressure test.
- c) All VGS-owned piping (piping on the inlet side of the meter) must meet the Department of Transportation Title 49 CFR Part 192, as adopted by the State of Vermont, referenced in Section 5, Laws & Governing Codes.
- d) Copper piping is not allowed for use on inside natural gas piping.
- e) Press connect fittings are not allowed for use on inside or outside piping installations.
- f) Four-inch (4-in) and larger piping must be welded.
- g) Pipe penetrations through concrete or masonry must be sleeved.
- h) Annular space around pipe penetrations must be sealed.
- i) Plastic buried customer owned piping should be installed with locator wire. The marking tape should be installed 1-ft. below the ground surface. Locator wire should be installed 6-inches above the installed piping.
- j) All piping exposed to the outside air must be protected from atmospheric corrosion. Two common methods of protection are to use galvanized piping or to paint all exposed piping.
- k) Piping installed above ground shall be securely supported and located where it will be protected from physical damage.
- l) Horizontal piping should be supported with metal angle brackets, metal split ring brackets, or metal straps.

Call the VGS Service Department at (802) 863-4511 with any questions regarding inside or above ground piping.

#### 9.3.2 Corrugated Stainless Steel Tubing (CSST)

- a) All CSST installations must meet NFPA 54 Natural Fuel Gas Code, NFPA 70 National Electrical Code, manufacturers installation instructions and VT Interim Bonding Requirements for CSST Gas Pipe.
- b) CSST piping installations must be electrically bonded by a VT Licensed Electrician and accessible for visual inspection.
- c) Direct burial and outdoor installations are prohibited.

### 9.3.3 Flexible Appliance Connectors

- a) Flexible connectors are permitted on ranges and dryers if black iron piping is properly supported and allowed per manufacturer instructions.
- b) Multiple connectors cannot be used together.
- c) Do not use when connecting free-standing space heaters, water heaters or central heating appliances.
- d) Do not conceal within or extend through walls, floors, partitions or ceilings.

### 9.4 Roofs for Meters/Regulators

Meter sets should be installed on the gable end and not under the drip line of a roof. However, if the meter set is under the drip line, it should be protected from snow, ice or dripping water that could freeze and damage the equipment. The roof should be constructed as follows:

- Extend out past the face of the meter.
- Width needs to extend on both sides of the meter assembly (including the regulator)
- Roof needs a minimum clearance of 6-inches from the top of meter assembly and the bottom of the roof.
- Be able to withstand falling icicles, ice chunks and ice and snow accumulations.

### 9.5 Barricades/Barriers

A barricade is required if the meter set is within three feet (3-feet) of a driveway, parking lot, sidewalk or any other location that a vehicle can easily access (see Figure 9.1).

- As a general rule, install barricades approximately four feet (4-feet) from the building's exterior, including a twelve-inch (12-inch) clearance from the front of the meter.
- Barricades are typically set a minimum of four feet (4-feet) into the ground in concrete. The barriers should extend above the meter set.
- Two posts are typically installed. Depending upon the location, a single barricade may be approved by a VGS Operations Manager.

**Residential:** Four-inch (4-inch) Diameter SCH. 80 Steel Post. Minimum three feet (3-feet) above grade. Concrete filled, painted, with a minimum ten-inch (10-inch) diameter Sonotube® or concrete base.

**Small Commercial and Apartment Complexes:** Four-inch (4-inch) Diameter SCH. 80 Steel Post. Minimum three feet (3-feet) above grade. Concrete filled, painted, with a minimum twelve-inch (12-inch) diameter Sonotube® or concrete base.

**Large Commercial and Industrial:** Six Inch (6-inch) Diameter SCH. 80 Steel Post. Minimum four feet (4-feet) above grade. Concrete filled, painted, with a minimum twenty-inch (20-inch) diameter Sonotube® or concrete base.

**Note:** Two (2) posts should be used when the maximum distance between posts are four feet (4-feet) or less. Additional posts must be installed when greater than four feet (4-feet).

## REGULATORS, METERS, PIPING & BARRICADES

---

1. In areas of potential vandalism, the customer may be required to provide a secure six foot (6-feet) tall chain link fence with a gate that can be locked. VGS will need a key or combination for access.
2. For information on meter pads, barrier placement, installations not covered above and other support methods contact the Operations Department at (802) 863-4511.

Figure 9.1 Barricade Requirements

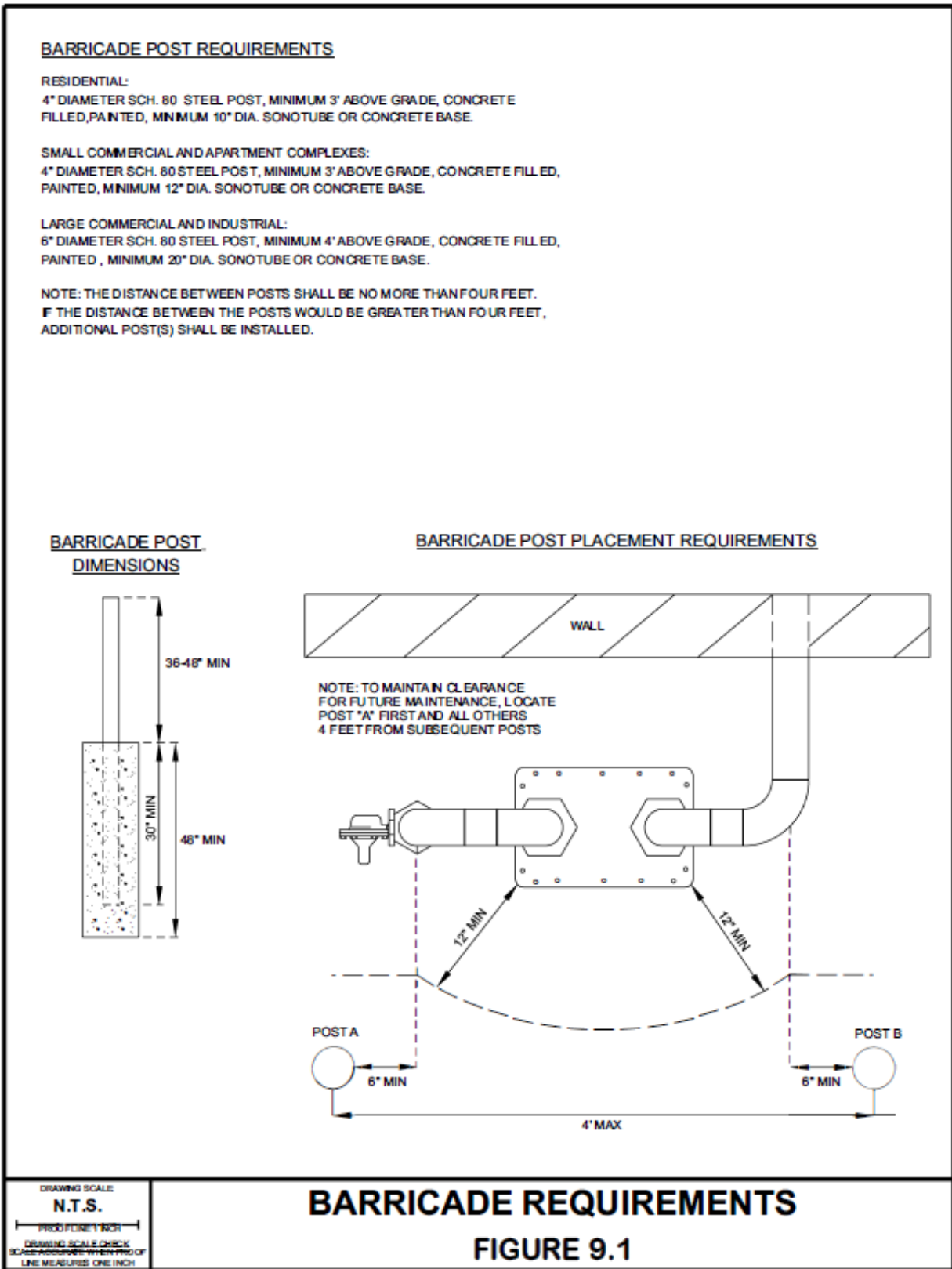

**9.6 Gas Meter Recess**

1. All entrances/penetrations into buildings shall be sealed properly.
2. Depth of recess must be 24-inches.
3. A four-inch (4-inch) diameter sleeve is required if paving during construction.

**Figure 9-2 Gas Meter Recess**

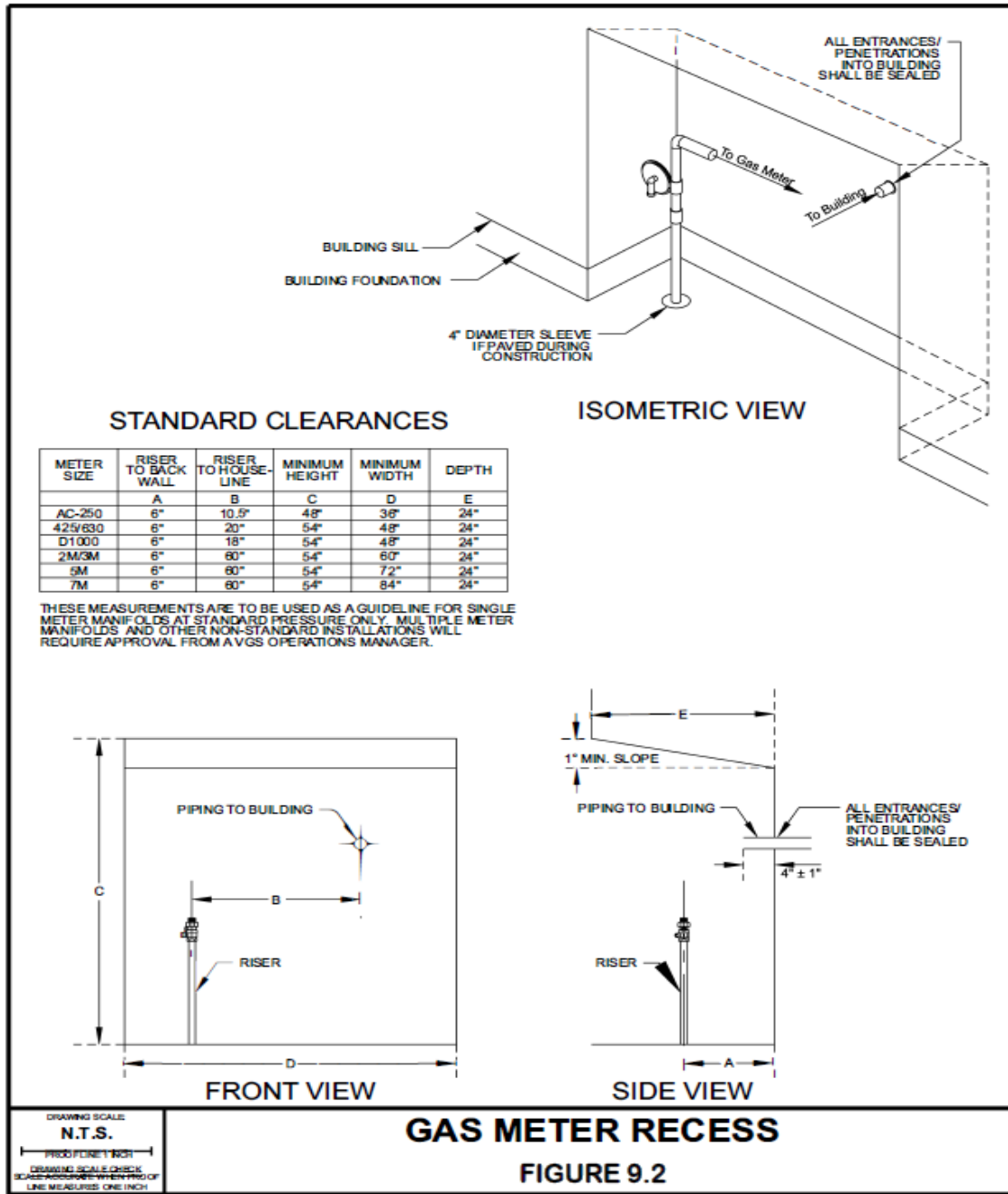

**9.7 Gas Meter Enclosures**

**VGS does not recommend that any gas meter be enclosed. However, if an enclosure is necessary, the following criteria apply along with VGS approval.**

1. All enclosure sides against the building shall be gas tight as to prevent gas migration into building. Enclosure sides are only permitted against exterior walls. There shall be no occupied space above the enclosure, it must be open air above the header and roof.
2. Provide a minimum of one hundred and twenty square inches (120 sq. in.) of free air space at the top and bottom of enclosure (if free air space of louver is unknown, use 75% of calculated surface area).
3. Enclosure shall be readily accessible for access and maintenance.
4. Either single or double door is allowed but must be no smaller than forty inches (40-inches) wide by thirty-six inches (36-inches high).

Figure 9-3 Gas Meter Enclosure

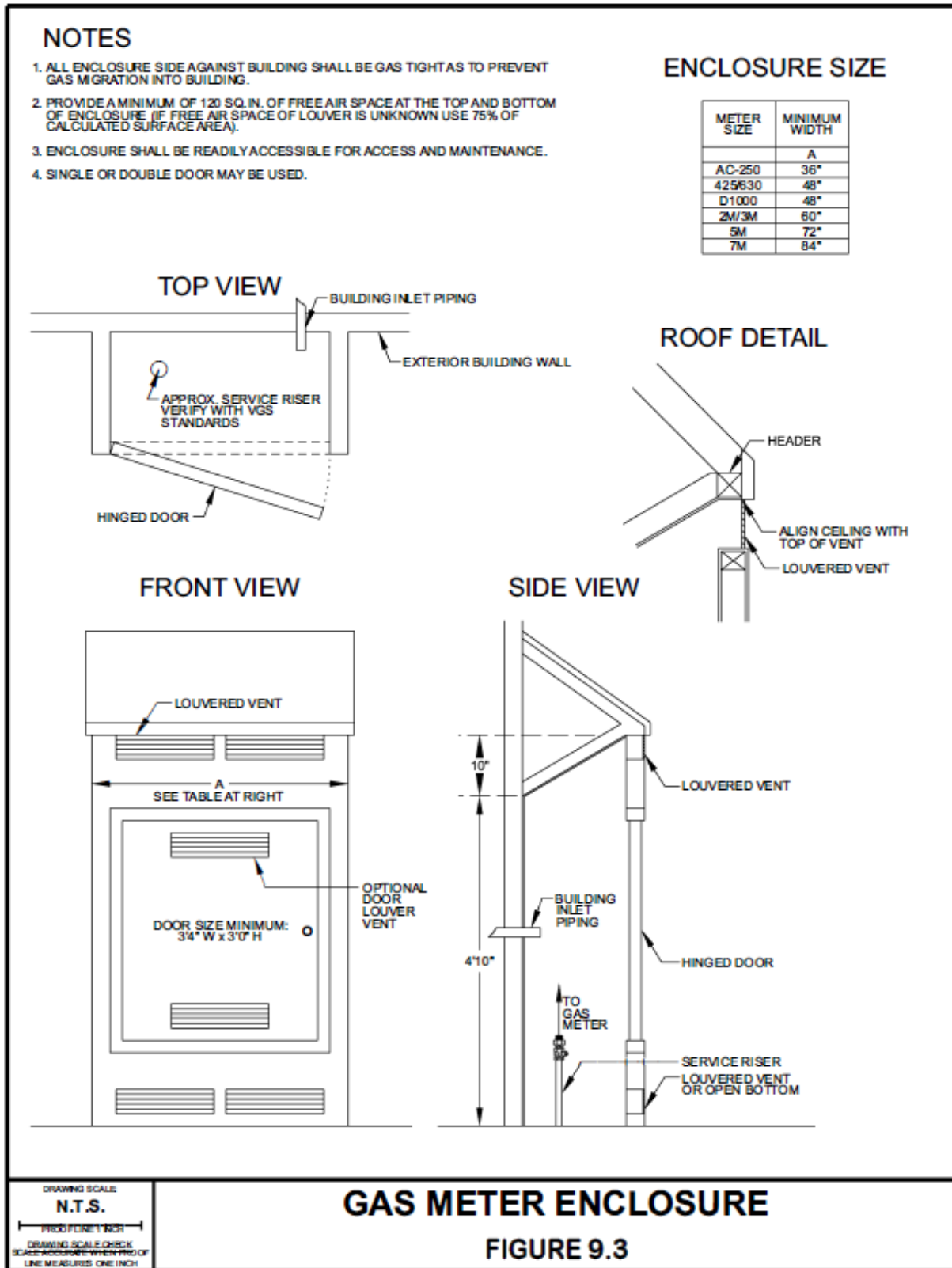

### 9.8 Elevated Gas Pressure

Gas pressure greater than seven inches (7-inch) W.C. is considered elevated pressure. Elevated pressure may be delivered downstream of the meter in the following situations, upon approval by the VGS Operations Department:

- a. Total customer volume requirement on a single meter exceeds three (3) MBTUs/hour
- b. Temporary heat for construction
- c. Special manufacturing loads
- d. Elevated pressure requires a rotary meter instead of a traditional meter. The working pressure will determine the size of the rotary meter required. See Figure A-6 for the design of a D1000, Figure A-7 and A-8 for the designs of a 2M/3M and 5M Rotary Meter.

A request for elevated pressure must include the following information:

1. 9-1-1 address of location
2. Equipment load list
3. Supply a drawing with the meter location, a piping diagram and location of regulators. The location must allow for the regulator to be located more than 3-ft from any opening and room for barricades if needed to protect the meter set.

When a request for elevated pressure is approved, VGS will provide five (5) psig downstream of the meter. A pressure test is required before VGS will turn on the meter (see form in Appendix B).

The customer is responsible for the following:

- Piping (inside and outside) need to be welded and labeled according to ANSI/ASME A13.1 pipe marking guide to indicate elevated pressure in piping
- Outside piping must be galvanized or painted.
- Install a ½-inch weld-o-let with a valve and plug for VGS to pressure test and verify 5 lbs. of pressure
- **Pressure reduction from five (5) psig or less to the equipment utilization pressure**
- Provide and maintain the overpressure protection equipment

### 9.9 Pressure Tests

Your contractor is required pressure test piping as specified in NFPA 54, to ensure there are no leaks and VGS recommends a soap test be performed on all connections during the pressure test. VGS requires a pressure test form for any new turn-ons or additional piping. See Appendix B for VGS Pressure Test form.

## **SECTION 10: Working in the Vicinity of Gas Lines**

### **Damages to VGS piping system**

1. **If ANY VGS LINE IS DAMAGED AND LEAKING (OR POSSIBLY LEAKING), CALL 911.** After calling 911, notify VGS at 1-800-639-8081 or (802) 863-4511 to report the emergency. Do not attempt to contact individuals at VGS.
2. All other damage should be reported to VGS at 1-800-639-8081 or (802) 863-4511.
3. All damages to VGS-owned facilities and gas lines shall be immediately reported to VGS. The damages shall be repaired by VGS maintenance personnel prior to backfilling.
4. All coating damage to steel gas lines shall be reported immediately to VGS. Coating breaks shall be repaired by either VGS maintenance personnel or by approved and qualified contractors prior to backfilling.
5. All breaks and damages to tracer wire for plastic pipe shall be reported to VGS. The breaks and damages shall be repaired by either VGS personnel or by approved and qualified contractors prior to backfilling.
6. All damages to VGS cathodic protection facilities and cathodic protection test facilities shall be reported to VGS. The damages shall be repaired and tested by VGS personnel or by approved and qualified contractors prior to backfilling.
7. All damages to VGS test, locator, and valve boxes shall be reported to VGS. Either VGS personnel or approved and qualified contractors shall repair the damages. All VGS test, locator, and valve boxes shall remain accessible after any grade changes. Contact VGS for any boxes that need to be raised due to a grade change. No boxes shall be under cover.

### **Specifications and Requirements for All VGS Pipe**

1. Contractors are to conform to VGS Requirements listed in Section 7, General Requirements for Developers, Contractors & Builders.
2. No concrete, asphalt, or any other material that is not stone-free shall be in contact with gas lines.
3. Extra coating required for steel gas lines shall be done by VGS personnel or by approved and qualified contractors prior to backfilling.
4. If excavation activities require the gas distribution line to need support (i.e., suspended in ditch), piping supports of wood or I-beams should be installed until the pipe can be properly buried. Suggested support spacing is based on pipe diameter (see Tables 10-1 for steel and 10-2 for HDPE). If these requirements cannot be met, seek Engineering for specific guidance.
5. All exposed gas lines shall be padded with six inches (6-inch) minimum of sand or a stone free material prior to backfilling, unless otherwise stated by VGS specifications or drawings.

## WORKING IN THE VICINITY OF GAS LINES

---

6. If blasting will be within a two hundred foot (200-foot) radius of Gas Facilities, notify VGS. VGS will work with the blasting contractor before and after blasting to leak survey to ensure the safety of the public and all parties involved. Proper arrangements shall be made between the blasting contractor and VGS to coordinate schedules.

Blasting vibrations must be below two inches (2-inch) per second (IPS) Peak Particle Velocity. If 2-inch/second IPS is going to be seen at the pipelines, the blasting contractor needs to stop blasting until VGS can check that no pipeline facilities have been damaged. Before resuming blasting, a meeting between a VGS Operations Manager or Supervisor and the blasting contractor will be held to discuss the safety of VGS facilities.

<b>Table 10-1 Pipe Support (Steel)</b>	
Nominal Pipe Size, NPS	Suggested Maximum Span - Feet
1	9
2	13
3	15
4	17
6	21
8	24
12	30
16	35
Source: ASME B31.1, Table 121.5	

<b>Table 10-2 Pipe Support (HDPE Pipe, SDR 11)</b>	
Nominal Pipe Size, NPS	Suggested Maximum Span- Feet
3/4	9
2	15
3	18
4	20
6	25
8	28
10	30
12	34
16	38
Source: Plastic Pipe Institute	

### **Work in the Vicinity of VGS Transmission Pipelines:**

1. Call DigSafe.
2. Notify VGS of any excavations within one hundred (100 feet) of a VGS's transmission pipelines.
3. Any areas of exposed transmission pipe should be reported to VGS.

## SECTION 11: Infill Services & Natural Gas Service Line Installation

### 11.1 Infill Services

The following are prerequisites of service which the applicant subscriber(s), or its duly authorized officer/agent, agrees to meet:

1. The riser must be located to ensure the separation requirements for the gas regulator and potential ignition sources meets the criteria specified in Section 9.
2. Grade shall be within six inches (6-inch) of finished grade from street to building and **finished grade shall be marked on the foundation of the building with a horizontal line.**
3. All materials shall be cleared from facilities location, including trees and bushes.
4. Meter protection and/or pad must be in place, if required.
5. No ledge removal is required. (Ledge removal will require a negotiated excess charge for construction.)
6. No frost in the ground. (Frost in ground will require a negotiated excess charge for construction.)
7. No other parallel utilities shall be within three feet (3-feet) horizontally or one foot (1-foot) vertically of facilities location selected.

### 11.2 Natural Gas Service Line Installation

#### A. Prior to Construction

VGS personnel will pre-mark the construction area with white flags and/or paint. The One Call Center, DigSafe® #811, will be called to locate and map underground facilities within the pre-marked area. Privately owned sewer lines, water lines, irrigation lines, power, lighting and electric dog fences may not be clearly identified which sometimes makes them difficult to locate. To help identify sewer line locations, VGS personnel will attempt to document where the sewer line exits the structure and any other relevant information that may be provided by the resident in regard to underground utilities during a site visit. Locations having potential sewer line conflicts during the pre-marking process may require further investigation. The more potential conflicts, the higher the probability of that open trenching will be required.

#### B. Construction Methods

**Open Trenching** – This technique is the preferred method of installation when the locations of underground utilities such as water or sewer are unknown. An excavator will open a trench roughly one foot (1-foot) wide and three feet (3-feet) deep from the street up to your home or business in which to install the gas line. Once the line is installed, the trench will be backfilled and tamped (packed down).

**Plowing** – A technique that uses a machine that pulls along a sharp blade which slices through the ground ahead of a metal chute which places the pipe at any desired depth. An expander behind the plow blade is used to expand the ground and allow a pipe of a particular size to be pulled into the ground without opening a trench and creating the usual disturbance associated with an open excavation. This technology may be used if the location of all underground utilities is known.

**Directional Boring** – Commonly called horizontal directional drilling or HDD, is a mostly trenchless method of installing underground pipes, conduits and cables in a shallow arc along a prescribed bore path by using a surface launched drilling rig. Directional boring is used to limit surface disturbance. This technology is used if the location of all underground utilities is known.

**Pneumatic Boring** – A technique to bore a hole underground between two points without disturbing the surface ground. It uses compressed air and a “mole” to tunnel underground without disrupting or damaging underground infrastructure. This technology can only be used if the locations of all underground utilities are known. An excavation measuring approximately four feet by three feet (4-feet x 3-feet) is made which is usually located near the roadway. The mole is placed in the excavation and bores a hole, compacting and displacing the soil underground rather than removing it. A second four feet by three feet (4-feet x 3-feet) excavation is made to receive the mole. Excavation pits are required approximately every forty feet (40 feet).

**Pneumatic Boring**

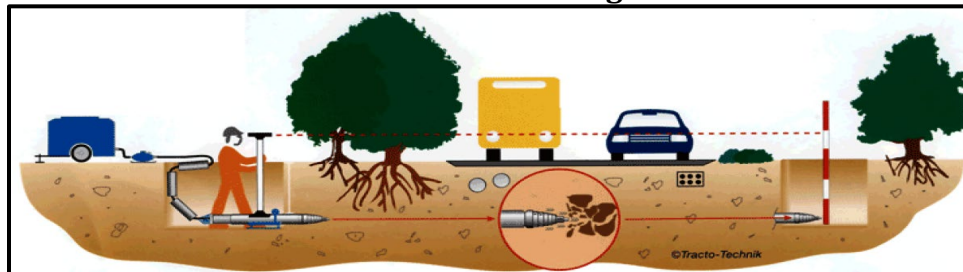

### C. Post Construction

VGS or its contractors will be back within seven (7) days to perform clean up, topsoil, seed, and mulch any areas that have been disturbed during the installation of the natural gas line. In order to ensure proper growth of the grass, please water the seeded area twice per day. VGS will not be responsible for the non-growth of grass because of lack of watering. VGS will occasionally conduct post-construction camera inspections of the sewer system to reduce the risk of Cross Bores that are defined in Section 4, DigSafe® & Cross Bores. To complete these inspections, VGS and our third-party contractor may require access to the residence to complete the inspection.

## **SECTION 12: Fuel Lines, Pool Heaters & Underground Piping**

To run underground piping to a pool heater or secondary building, you must first understand the responsibilities of VGS and those of your contractor.

VGS does not monitor or maintain customer-owned fuel lines as part of its distribution system. Buried piping that is not maintained is subject to the potential hazards of corrosion and leakage. Your piping should be periodically inspected for leaks regardless of the pipe material. If an unsafe condition exists, repairs should be made as soon as possible. Contact VGS if you need assistance finding resources for these services.

The property owner shall hire a qualified contractor for installations of underground piping beyond the outlet of the gas meter. The material and testing shall meet all applicable Federal and State regulations and VGS Standards.

### **12.1 Getting Started:**

1. You and your contractor should determine the size and exact location of the additional gas appliances. Care shall be taken to install the appliances in accordance with the manufacturer's installation instructions. This will allow your contractor to accurately estimate the gas load, length, size, and cost of the underground piping.
2. Contact VGS to check gas load – VGS shall determine if the current service regulator and meter is properly sized to handle the added load. VGS may require your contractor to complete a GAS LOAD SHEET (list of all gas appliances and their input rates) which will be used to properly size the gas meter. If it is determined that a larger gas meter is needed, one will be installed by VGS.

### **12.2 Next Steps - Customer & Contractor Responsibilities**

1. Call in a Dig Safe® request (dial 811) at least seventy-two (72) hours or three (3) business days, whichever is greater, prior to excavating. This is a free service through a toll-free call, which alerts utility owners that excavation will be taking place. If needed, the utility companies will visit the work site and mark out the locations of their facilities. This process assists in the safety of the excavator and prevents utility damage. If you have any question on the Dig-Safe® process, please call the VGS Engineering Department at (802) 863-4511.
2. VGS recommends the contractor dig a ditch, at least thirty-six inches (36-inch) deep, from the appliance or secondary building wall to the primary building or outlet side of the meter (right hand side as you face the meter). The bottom of ditch shall be flat and free of rocks and stones. VGS requires six inches (6-inch) of sand padding all around pipe in rocky soil conditions.
3. The customer or contractor will be responsible for backfilling the remainder of the ditch. Your contractor is responsible for installing the high-density polyethylene pipe, anode-less risers, tracer wire, and warning tape. The customer will also be responsible for installing the locator wire six inches (6-inch) above the pipe and the warning tape six to twelve inches (6 or 12-inch) below finish grade.

4. All high-density polyethylene (HDPE) pipe and medium density polyethylene (MDPE) and all fittings must be below grade to ensure zero exposure to ultra-violet light, which degrades the pipe.
5. Pressure Test – Your contractor is required to pressure test piping as specified in NFPA 54, to ensure there are no leaks. VGS requires a pressure test form for any new turn-ons or additional piping that exceeds 10% of the existing pipe currently installed. Use the VGS Pressure Test Form in Appendix B.
6. Final connections to the meter and appliance (pool heater, etc.) will be the customers' responsibility. If the customer desires, VGS can provide this service for a nominal charge. An appointment can be arranged by calling VGS at (802) 863-4511.

### **12.3 Final Steps**

1. Provide VGS with a copy of the pressure test.
2. For any questions regarding specific underground piping installations such as elevated pressure, using alternative materials, dielectric and insulated fitting requirements, or shut off location requirements, contact VGS at (802) 863-4511 and ask for Operations Department.

## **SECTION 13: Natural Gas Service to Mobile Homes and Mobile Home Parks**

VGS will provide natural gas service and conversion of customer appliances to mobile homes and mobile home parks if the following conditions are met.

### **13.1 Feasibility**

The project must meet the feasibility requirements of VGS' line extension policy.

### **13.2 Natural Gas Distribution Main**

1. Owners must provide an easement for the installation and operation of the pipelines. The easement width will be a minimum of five feet (5-feet).
2. There must be a minimum of five feet (5-feet) of open space between the paved roadway and any structures in order to install the main line adjacent to the roadway.
3. There must be a minimum of three feet (3-feet) separation between the natural gas main pipeline and any other underground utilities such as electricity, water, sewer, etc.
4. All underground utilities must be located and marked by the Owner of the property.

### **13.3 Natural Gas Service Lines**

1. Only mobile homes that are constructed to HUD standards (constructed after June 15, 1976) are eligible for natural gas service.
2. The mobile home must be blocked up, stable, and have its wheels and hitch removed to receive service.
3. Foundations - Mobile homes installed on a slab or masonry foundation walls shall follow standard residential meter set standards. If a pad or masonry foundation is not present, the meter assembly shall be supported by a meter support post and the connection from the meter outlet to the mobile home shall utilize a flexible connector approved for outdoor use.
4. Flexible connectors shall be no more than six feet (6 feet) in length, rated for outdoor use, sized adequately for the connected load, be installed completely outside the skirting to allow visual inspection, and installed with a loop to allow for settling or movement of the home.
5. The riser and meter will be located in an area that is protected from vehicle traffic.
6. In cases where there is no foundational support for the riser and meter, an additional support for the meter and the riser shall be required and will be provided by the company.
7. There must be a minimum of ten feet (10 feet) separation between adjacent mobile homes in order to install the service line.
8. All service lines will have a flow limiter installed.

### **13.4 Conversion of Appliances**

1. All appliances must be in good condition, accessible and approved for use in a mobile home.
2. There must be a minimum of two feet (2-feet) of ground clearance underneath the mobile home.
3. On double wide mobile homes, the crossover piping must be exposed. If it is not exposed, it will need to be replaced.
4. Mobile home will have a tag affixed to the outside of the home conveying the appliances have been converted to natural gas.
5. See Figure 13.1 for the full design of the mobile home meter post.

Figure 13-1 Mobile Home Meter Support

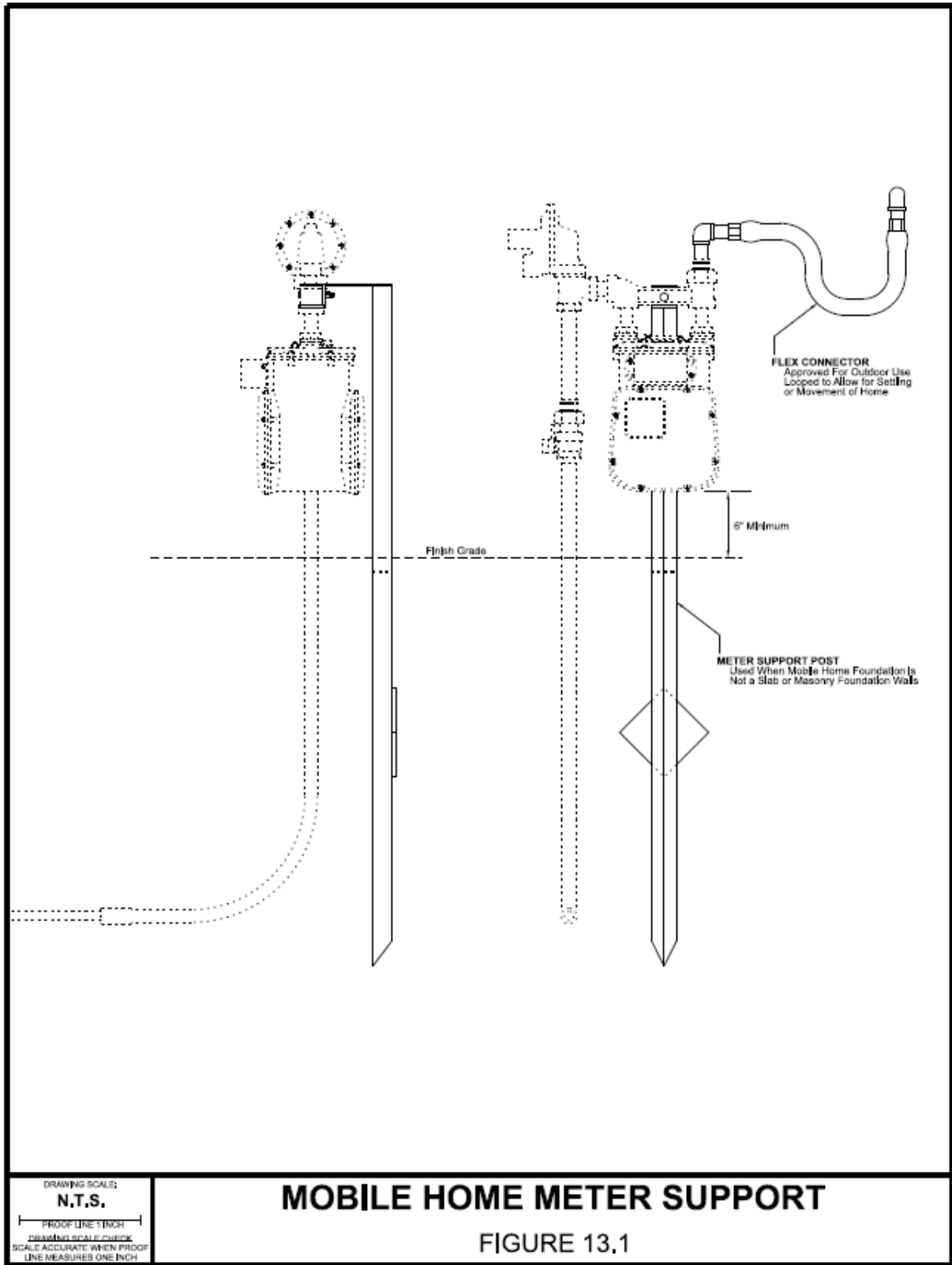

## **SECTION 14: Customer Dig Guidelines**

### **14.1 Permits**

Excavation Permits - It is the responsibility of the Customer/Developer to acquire the necessary state and local excavation permits. The permit must have VGS listed as the co-applicant.

Wetlands Permits – VGS will determine if a wetlands permit may be needed. It will be the responsibility of the Customer/Developer to obtain the field data required to determine if a permit is needed and obtain the Wetland permit if necessary.

Construction Stormwater Permit- VGS will determine if a Stormwater permit may be needed. It will be the responsibility of the Customer/Developer to obtain the field data required to determine if a permit is needed and obtain the Stormwater permit if necessary.

### **14.2 Easements**

VGS will obtain the necessary ROW/easement documents when required. All easements must be signed and ready for filing in the public record prior to installing pipe.

### **14.3 Digging within a Public Right of Way**

Customer digs within the public Right of Way requires approval by the VGS VP of Operations. VGS will also require the Customer/Developer to place a deposit with VGS of \$4.00 (four) dollars per foot of disturbance. This deposit will be held until the cleanup of the project has been approved by the Owner of the Public Right of Way. Upon approval, the deposit will be returned to the Customer/Developer. If the Customer/Developer cleanup fails to get the approval of the Owner, VGS will use the deposit monies and provide the cleanup services to the satisfaction of the Owner.

### **14.4 Dig Safe**

The Customer/Developer will be required to obtain a valid DigSafe® number with VGS named on it and be aware of utility marking in the proposed work area. The DigSafe® system includes all areas that VGS and Developer may excavate. DigSafe® can be contacted by dialing 811. Please have your DigSafe® ticket number prior to calling to schedule the installation.

### **14.5 Scheduling of Construction**

To schedule your customer dig with VGS, please contact your sales representative at (802) 863-4511. Please allow a minimum of two (2) week scheduling lead time. Any requests less than two weeks will be processed on a best efforts' basis. Please note that scheduling will depend on number of installations already scheduled.

Approximately seventy-five percent (75%) of ditch length or four hundred (400 feet), whichever is less, should be trenched and available for pipeline installation prior to VGS's arrival on the scheduled date. On large jobs, alternative ditch lengths can be arranged with prior approval of the VGS's Operations Department. Trench shall be prepped and ready for

pipeline installation prior to VGS personnel arriving on site. Down time incurred waiting for ditch to be excavated or equipment to arrive may be billed to the customer/developer or may require the job to be rescheduled.

### 14.6 Construction

- The trench shall meet all OSHA standards. VGS requires the bottom of the trench to be sand padded with 6-inches of sand prior to installing the gas pipeline. Spoil piles will be a minimum of two feet (2 feet) from the edge of the trench. If water is present, the trench shall be made safe and verified by VGS personnel. See Figure 7.1 for a detail of a typical trench.
- Customer/Developer **will not** expose VGS facilities. VGS personnel will be responsible for all excavation over live gas pipelines. Customer/Developer will stop digging five feet (5 feet). from VGS facilities. Customer/Developer can dig around and expose gas facilities if VGS personnel are on site.
- During regular construction season (May 15 – November 15), VGS will be responsible for road crossings unless circumstances dictate the developer be responsible. VGS will provide prior notification to developer should they be required to do a road crossing. Shall the Customer/Developer be responsible for any sleeving or casing; multiple sleeves/casings are not an acceptable practice.
- Customer/Developer will supply sand padding above and below the pipe as required by VGS. After adding the sand padding, existing backfill material may be used if stones are not larger than six inches (6-inch) in diameter and the backfill is free of organic material (mulch or sod), trash, asphalt and concrete.
- All installed pipe will meet minimum standards per federal code including sites under construction or reconstruction (2-ft. minimum for mains, 12-inches for services). Final grade should meet VGS standards for cover (3-ft for mains and 24-inches for services).
- State road crossings require a VTrans permit, protective sleeve and depth of 5-ft. minimum. State road crossings are public Right of Ways. See Section 14.3 for additional requirements.
- Customer/Developer is responsible for all restoration, including concrete and blacktop that the Customer/Developer has disturbed. VGS will be responsible for all restoration, including concrete and blacktop that VGS has disturbed. Customer/Developer should make the best effort to backfill to finish grade the day of installation for locating proposes.
- Winter construction will be weather dependent and at the discretion of VGS to ensure the safety of all personnel. VGS will not excavate over live gas lines where frost conditions exist. Customer/Developer will make every effort to thaw the ground above gas lines. Backfill material will not be used if frozen. During winter construction, the customer/developer will be responsible for all sidewalk and road crossing installations.

## CUSTOMER DIG GUIDELINES

---

- VGS may pay the Customer/Developer up to nine dollars per foot (\$9.00/Foot) of trench for gas main installations. VGS will reimburse costs for sand required for sand padding but not the associated trucking.

# Appendix A: Meter Diagrams

Figure A-1 Meter Clearances

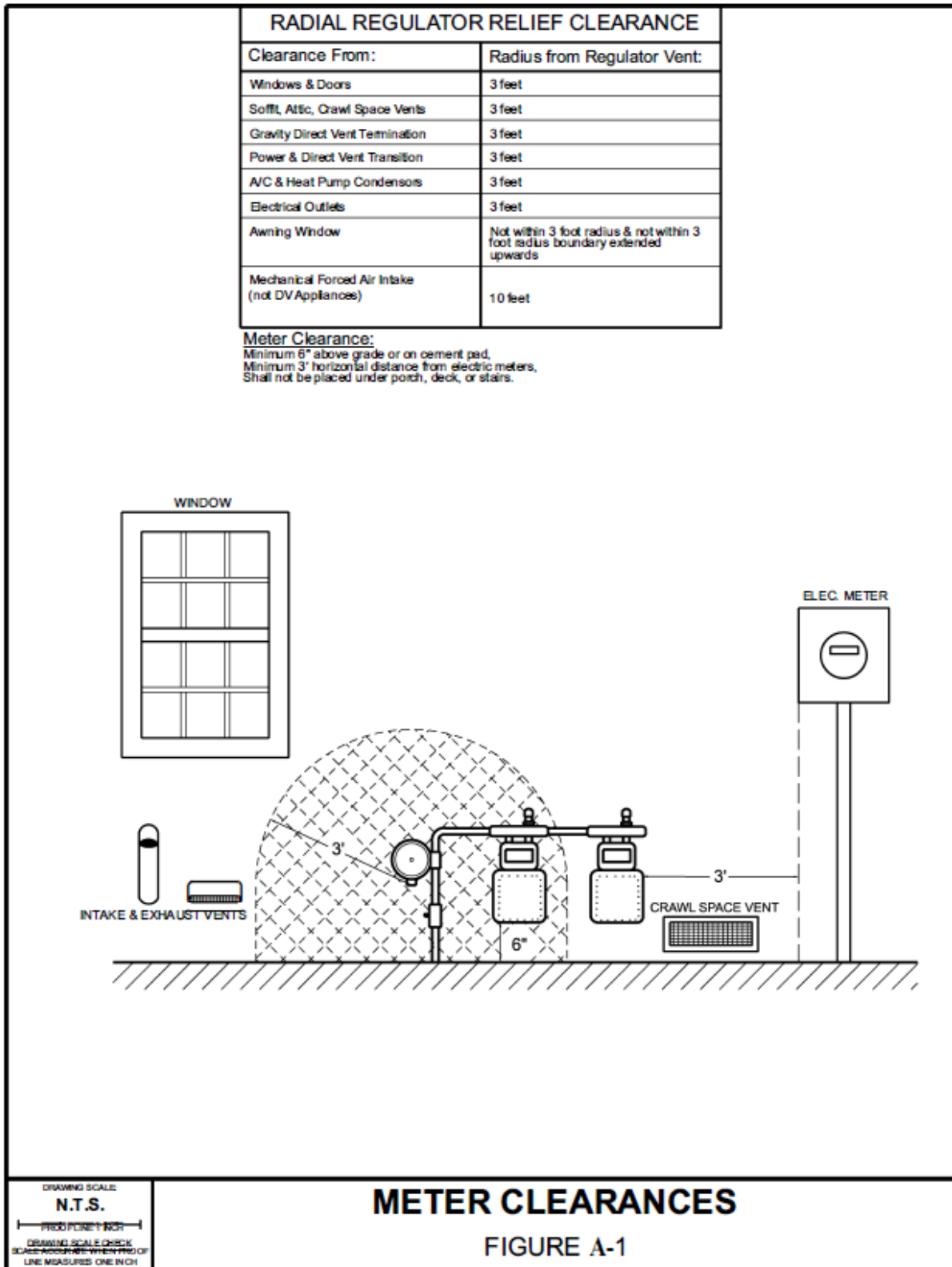

Figure A-2 AC250 Single Meter Manifold

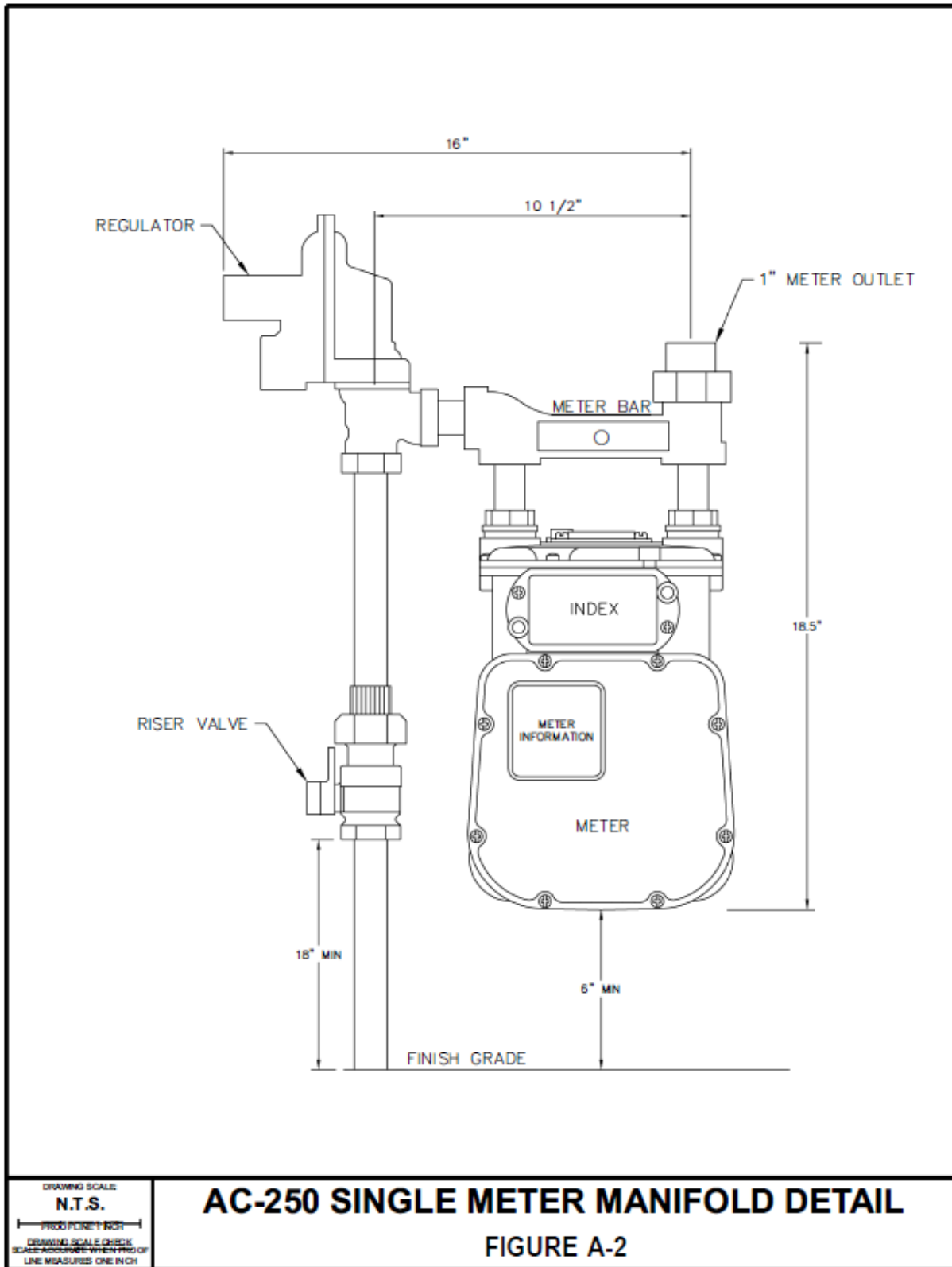

Figure A-3 AC250 Multi-Meter Manifold

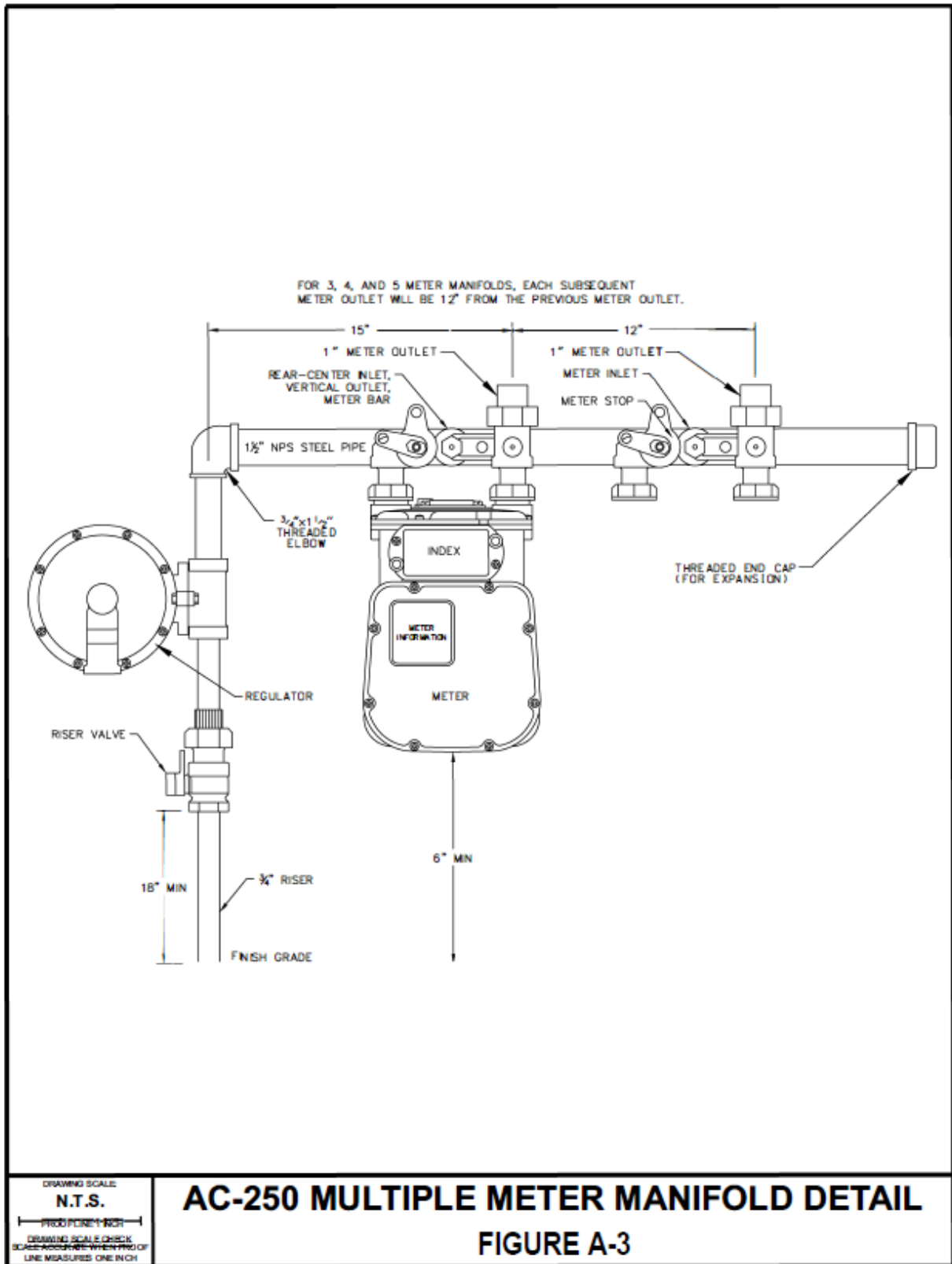

Figure A-4 Multi-Meter Manifold AC-250 /AC-425 /AC-630

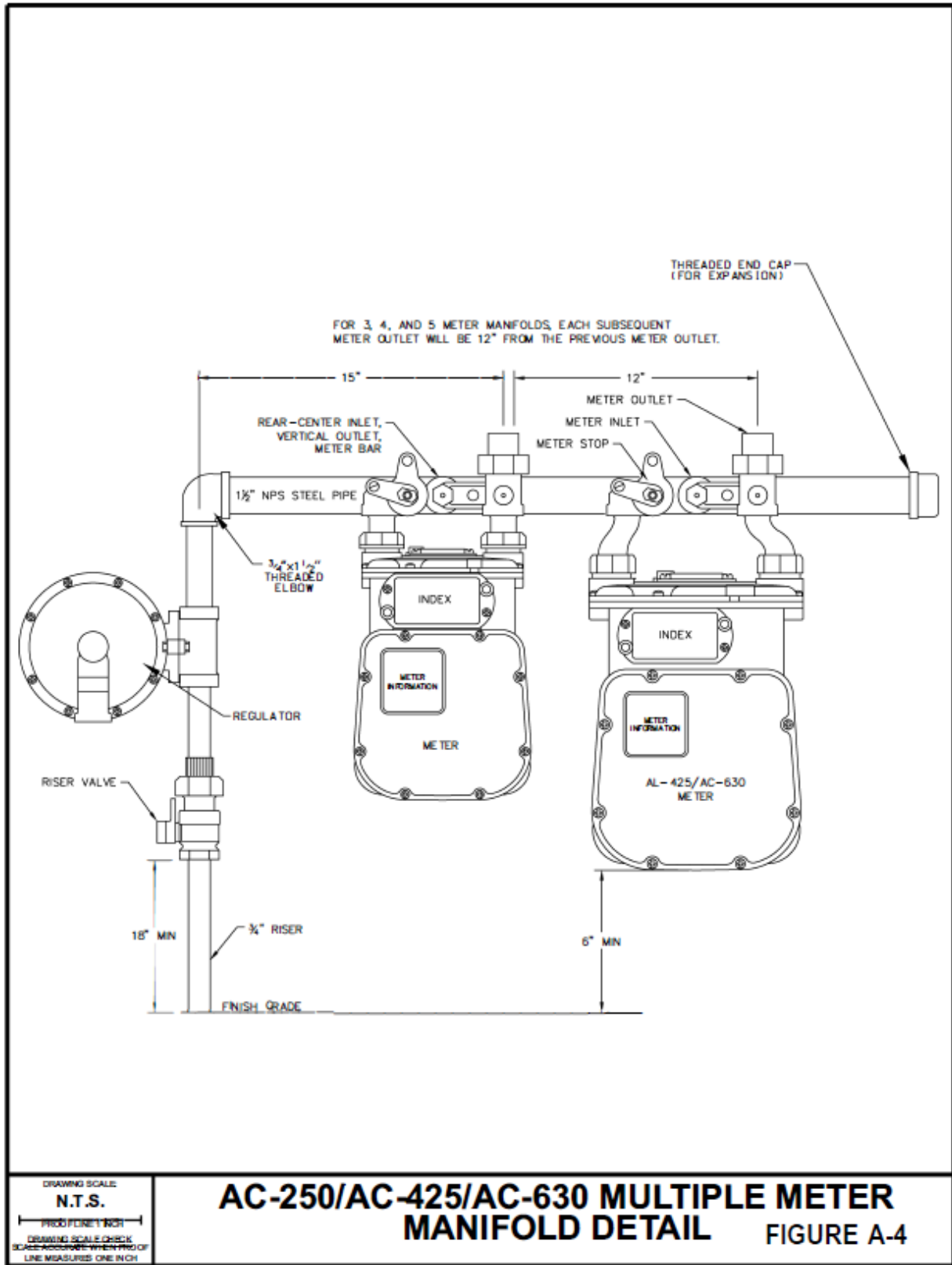
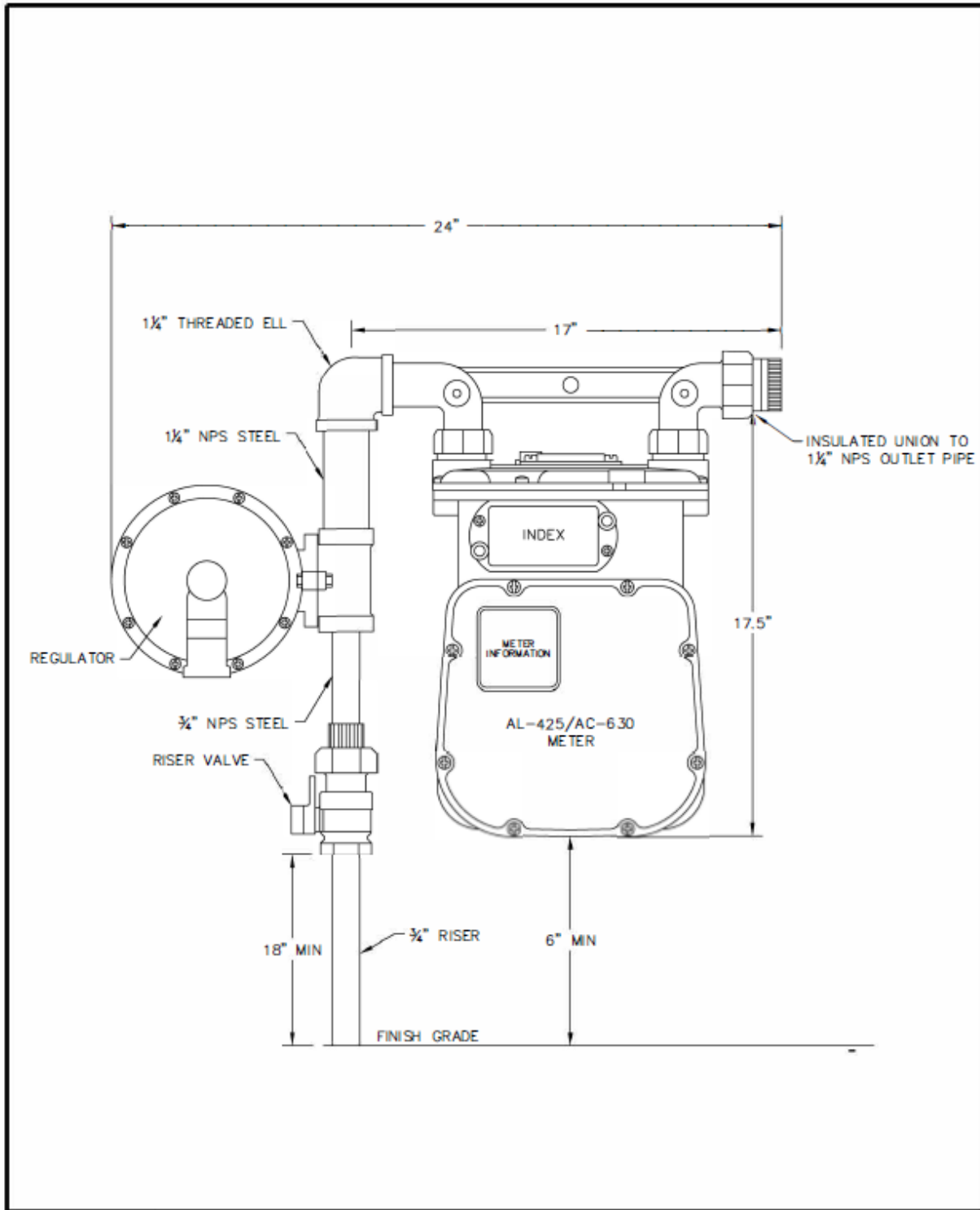

Figure A-5 AC-425/ AC630 Single Meter Manifold Detail



DRAWING SCALE:  
N.T.S.  
1" = 1'-0"  
DRAWING SCALE CHECK  
SCALE: ALL DIMENSIONS UNLESS NOTED  
LINE MEASURES ONE INCH

### AC-425/630 SINGLE METER MANIFOLD DETAIL

FIGURE A-5

Figure A-6 D1000 Single Meter Manifold

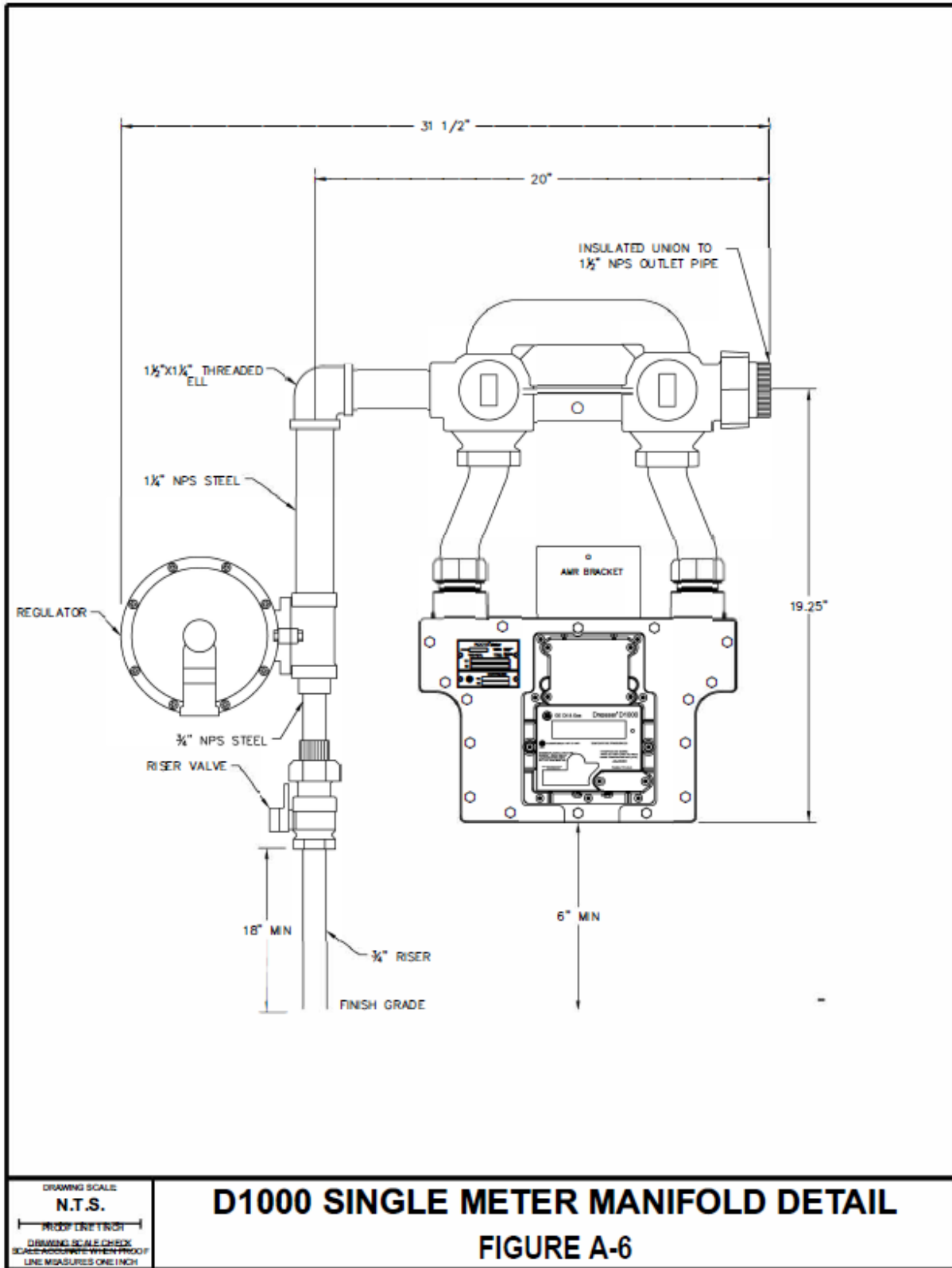

Figure A-7 2M / 3M Meter Manifold Detail

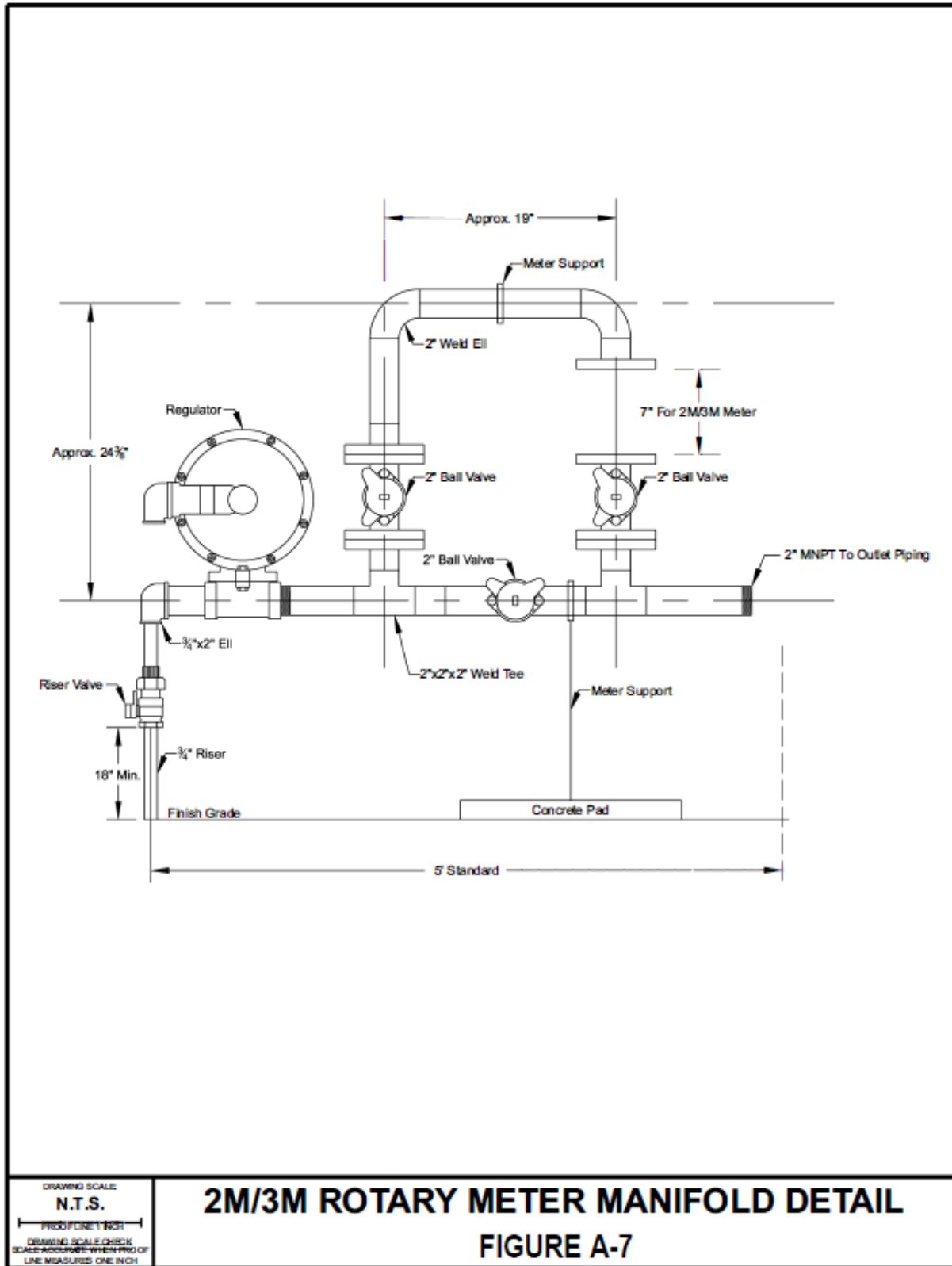
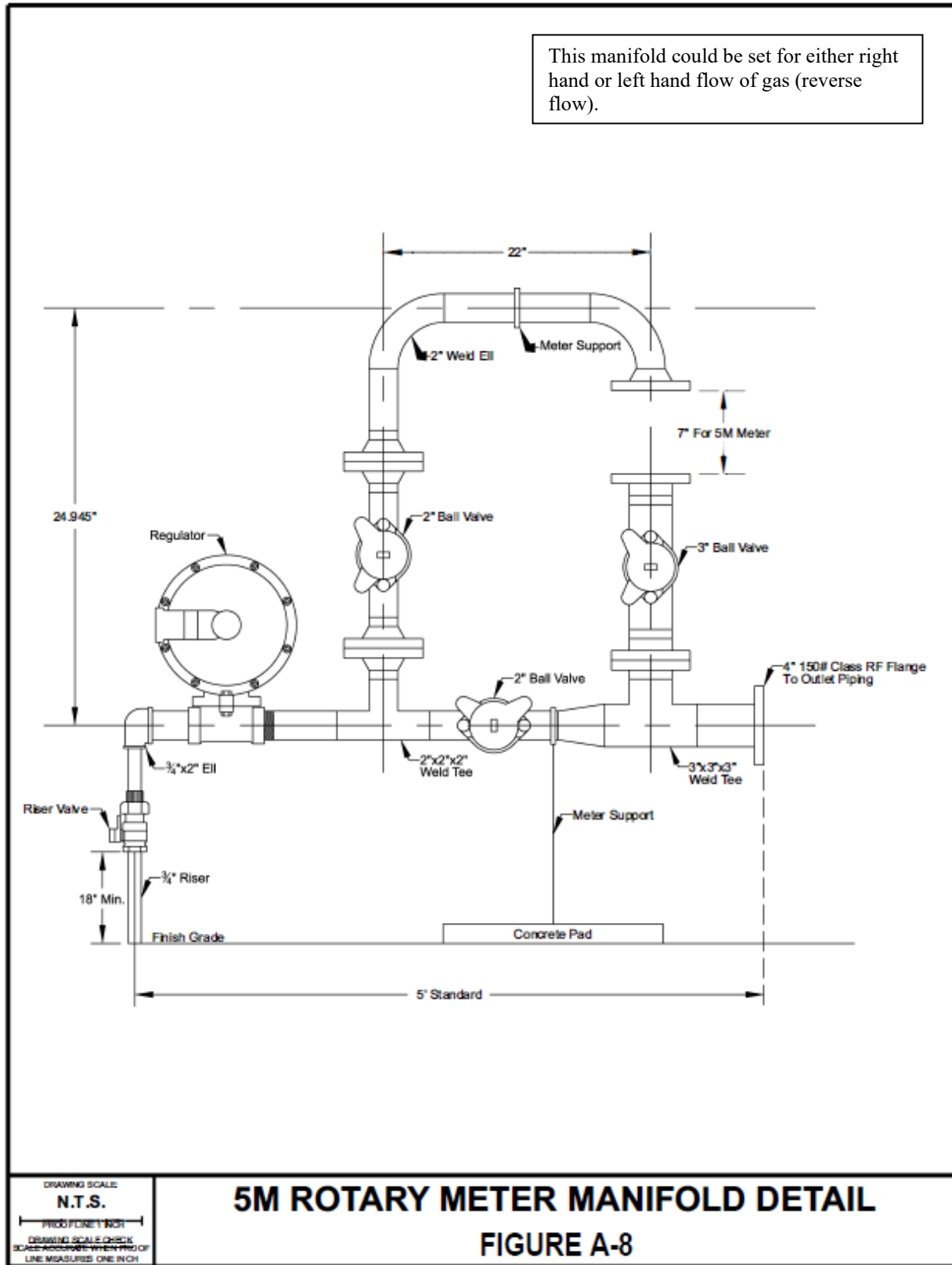

Figure A-8 5M Rotary Meter Manifold Detail



## **Appendix B: VGS Pressure Test Form**

## VGS Pressure Test Form

VGS requires pressure test results for all piping installations on all multi-family, commercial properties, and concealed CSST installations. The test information must be provided on this form and sent to the following address. Only Natural Gas certified personnel should perform the pressure test and sign the form.

Manager of Field Services  
P.O. Box 467  
Burlington, VT 05402-0467  
Fax: 802-863-8872

I, \_\_\_\_\_, representing \_\_\_\_\_  
(Print name in full) (Company)

hereby certify that the gas piping installed by my company at the following address has passed a suitable pressure test, as outlined in the National Gas Code, NFPA 54.

**Job Location:**

\_\_\_\_\_  
(number) (street) (apt. #)  
\_\_\_\_\_  
(town) (state) (zip)

**Test Date:**

Test Medium: \_\_\_\_\_  
Air Nitrogen Other inert gas

**Test Pressure:**

\_\_\_\_\_  
(1-1/2 times maximum working pressure, minimum 3 bls.)

**Test Duration**

\_\_\_\_\_  
(1-1/2 hour for each 500 cu.ft. of pipe volume, 10 min. for vol. less than 10 cu.ft. or single family dwellings)

**Soap Test on fittings:** Yes/No (circle)

Signed: \_\_\_\_\_

Title: \_\_\_\_\_

Witness: \_\_\_\_\_

Natural Gas Certification #: \_\_\_\_\_

**Note:** Gas meters will not be turned on without properly completed and signed test forms.