PROJECT MANUAL
CONFORMED CONTRACT DOCUMENTS

**PROPOSED SYSTEM EXPANSION
ADDISON NATURAL GAS PROJECT
TRANSMISSION MAIN CONTRACT**

May 23, 2014

**CHA PROJECT #: 24381
VGS PROJECT #: VGS2014-01**

Prepared for:

**Vermont Gas Systems, Inc.
85 Swift Street
South Burlington, VT 05403**

Prepared by:

**CHA
III Winners Circle
Albany, New York 12205
(518) 453-4500**

DRAFT - NOT FOR CONSTRUCTION

CONTRACT DOCUMENTS LIST

INVITATION TO BID	NTB-1
INSTRUCTIONS TO BIDDERS	ITB-1 TO ITB-7
INFORMATION AVAILABLE TO BIDDERS	IAB-1
AGREEMENT	A-1 to A-5
CONSTRUCTION PERFORMANCE BOND	2 Pages
CONSTRUCTION PAYMENT BOND	3 Pages
GENERAL CONDITION	GC-1 to GC-35
SUPPLEMENTAL CONDITIONS	SC-1 TO SC-10
SUPPLEMENTAL CONDITION ATTACHMENTS - Volume 2 (available digitally @ https://www.chafiles.com/FS/v.aspx?v=8d6d678a60a8a27b6b96):	
-Vermont Department of Environmental Conservation (VTDEC) Individual Stormwater Construction Discharge (INDC) Permit Application (7/03/13)	
--VTDEC Draft Individual (3/24/14) Construction Stormwater Discharge Permit #6949	
-Response to comments to the 6/28/13 INDC permit application and supplemental application materials (9/20/13)	
-VTDEC Individual Wetland Permit Application (7/10/13)	
-VTDEC Individual Section 401 Water Quality Certification Application (7/10/13)	
--Draft Water Quality Certification (no date – issued with Post Bid Bulletin 4)	
-VTDEC Stream Alteration/FEH Documentation (7/1/13)	
-United States Army Corps of Engineers (USACE) Section 404 Individual Permit Application (7/10/13) includes USACE Rivers and Harbors Act Section 10 Permit Application	
-VTrans 1111 Permit Application (4/16/13)	
-Memorandum of Understanding between Vermont Gas Systems and the Vermont Agency of Natural Resources (9/13/13)	
-Vermont Department of Public Service Petition for Certificate of Public Good Cover Letter (6/28/13) and J. Nelson prefiled testimony.	
-- Certificate of Public Good issued by State of Vermont Public Service Board (12/23/13)	
-VELCO Technical Memorandum (10/1/2012)	
-Genesee & Wyoming Railroad Services, Inc. Permit Applications (Colchester and Williston)	
--Genesee & Wyoming Permit/Agreement No. 7092 (Essex)	
--Genesee & Wyoming Permit/Agreement No. 7093 (Williston)	
-Local/Town Permits	
--Town of Colchester (12/19/2013)	
--Town of Essex (1/17/2014)	
-- Town of Williston (12/13/2013)	
-- St. George, Hinesburg, Monkton, New Haven, Middlebury (Pending)	

Add "(5/23/14)" to all CDL documents that aren't otherwise dated.

Revise this hyperlink to the following: <https://www.chafiles.com/fs/v.aspx?>

Include CDL tables as part of this section - should be "CDL - Page X of 12"

CONTRACT DOCUMENTS LIST

-Additional Memorandum of Understandings

- Town of Monkton (6/14/13)
- Monkton Central School (6/11/13)
- Vermont Agency of Agriculture (6/13/13)
- Addison County Regional Planning (8/12/13)
- VELCO (6/12/13)

-Construction Line List with Conditions (11/12/13)

-Blasting Plan for Addison Natural Gas Project (June 25, 2012)

ADDENDUM (Addendum attachments are available electronically)

- Addendum 1 (10/18/2013)
- Addendum 2 (10/29/2013)
- Addendum 3 (11/13/2013)
- Addendum 4 (11/26/2013)

POST BID BULLETIN (Post Bid Bulletin attachments are available electronically)

- Post Bid Bulletin 1 (1/16/2014)
- Post Bid Bulletin 2 (1/16/2014)
- Post Bid Bulletin 3 (2/14/2014)
- Post Bid Bulletin 4 (4/1/2014)

TECHNICAL SPECIFICATIONS

**DIVISION VGS – SPECIAL CONSTRUCTION
(GAS PIPELINE)**

VGS Operation & Maintenance Manual – Abridged
Version for Transmission Construction Contractors
2013*

Vermont Gas ANGP Project Scope of Work and
Specifications

DIVISION 01 – GENERAL REQUIREMENTS

- 011000 Summary
- 012300 Alternates
- 012600 Contract Modification Procedures
- 012900 Payment Procedures
- 013000 Project Management and Coordination
- 013200 Construction Progress Documentation
- 013300 Submittal Procedures
- 014000 Quality Requirements
- 014200 References
- 015000 Temporary Facilities and Controls
- 015700 Maintenance and Protection of Traffic
- 017300 Execution
- 017700 Closeout Procedures
- 017839 Project Record Documents

DIVISION 02 – EXISTING CONDITIONS

- 023219 Exploratory Excavations

DIVISION 09 – FINISHES

- 099000 Mainline Valve Assembly Painting

DIVISION 13 – SPECIAL CONSTRUCTION

- 130000 VGS Paralleling High Voltage
Transmission Lines
- 136000 Mainline Valve Piping Fabrication

DIVISION 26 – ELECTRICAL

- 260501 Electrical – General Installation
Requirements
- 260521 Wire and Cable
- 260527 Grounding and Bonding Systems
- 260534 Conduits
- 260800 Electrical Acceptance Testing

DIVISION 27 - COMMUNICATIONS

- 270000 Data and Communications

DIVISION 31 – EARTHWORK

- 310519.13 Geotextiles for Earthwork
- 312000 Earth Moving
- 312316.26 Rock Removal
- 312319 Dewatering
- 312333 Trenching and Backfilling
- 312500 Erosion and Sedimentation Controls
- 313710 Riprap and Stone Fill
- 315000 Excavation Support and Protection

CONTRACT DOCUMENTS LIST

DIVISION 32 – EXTERIOR IMPROVEMENTS

321116 Subbase Courses
321216 Asphalt Paving
321500 Crushed Stone Surfacing

PROJECT PLANS (UNDER SEPARATE COVER)-

Refer to Contract Document List Table below

*NOTE: The VGS Operating and Maintenance Manual (the Manual) is a working document and is continually updated and improved. This Manual is controlled only by VGS. The included sections are for reference and bidding purposes only. If awarded the Transmission Phase Contract, the selected Contractor is required to contact VGS for the most current release of the Manual prior to beginning construction.

DRAFT - NOT FOR CONSTRUCTION

Add the prefix "CDL" prior to each Page x of y. Include the tables in the overall contract document list. Should be "CDL Page x of 12"

VERMONT GAS - PROPOSED 12" PIPELINE -
 ADDISON NATURAL GAS PROJECT - ALIGNMENT SHEETS

DWG NO.	REV. NO.	DATE	DRAWING TITLE - GENERAL
ANGP-T-G-001	0	06/28/13	COVER SHEET
ANGP-T-G-002	0	06/28/13	INDEX SHEET
ANGP-T-G-003	3	11/13/13	LEGEND & NOTES
ANGP-T-G-004	0	06/28/13	CONST. CONFIG. DETAILS
ANGP-T-G-005	1	09/20/13	CONST. CONFIG. DETAILS
ANGP-T-G-006	1	09/20/13	CONST. CONFIG. DETAILS
ANGP-T-G-007A	4	01/31/14	ACCESS ROAD DETAILS
ANGP-T-G-007B	2	02/21/14	ACCESS ROAD DETAILS
ANGP-T-G-008	2	11/13/13	ACCESS ROAD DETAILS
ANGP-T-G-009	4	02/24/14	ACCESS ROAD DETAILS
ANGP-T-G-010	1	01/31/14	ACCESS ROAD DETAILS
ANGP-T-G-011	N/A	N/A	NOT INCLUDED
ANGP-T-G-012	0	06/28/13	CONSTRUCTION DETAILS
ANGP-T-G-013	2	10/14/13	CONSTRUCTION DETAILS
ANGP-T-G-014	0	06/28/13	CONSTRUCTION DETAILS
ANGP-T-G-015	2	10/14/13	CONSTRUCTION DETAILS
ANGP-T-G-016	0	06/28/13	CONSTRUCTION DETAILS
ANGP-T-G-017	2	10/08/13	CONSTRUCTION DETAILS
ANGP-T-G-018	1	09/20/13	CONSTRUCTION DETAILS
ANGP-T-G-019	1	09/20/13	CONSTRUCTION DETAILS
ANGP-T-G-020	1	09/20/13	CONSTRUCTION DETAILS
ANGP-T-G-021	0	06/28/13	STA. & VALVE DETAILS
ANGP-T-G-022	1	11/13/13	WILLISTON PIPEYARD
ANGP-T-G-023	1	TBD	PLANK ROAD PIPEYARD
DWG NO.	REV. NO.	DATE	DRAWING TITLE - CIVIL
ANGP-T-C-001A	1	10/08/13	ALIGNMENT SHEET
ANGP-T-C-001B	1	10/08/13	ALIGNMENT SHEET
ANGP-T-C-002	1	10/08/13	ALIGNMENT SHEET
ANGP-T-C-003	1	10/08/13	ALIGNMENT SHEET
ANGP-T-C-004	1	10/08/13	ALIGNMENT SHEET
ANGP-T-C-005	2	03/26/14	ALIGNMENT SHEET
ANGP-T-C-006	1	10/08/13	ALIGNMENT SHEET
ANGP-T-C-007	1	10/08/13	ALIGNMENT SHEET
ANGP-T-C-008	1	10/08/13	ALIGNMENT SHEET
ANGP-T-C-009	1	10/08/13	ALIGNMENT SHEET
ANGP-T-C-010	1	10/08/13	ALIGNMENT SHEET
ANGP-T-C-011	1	10/08/13	ALIGNMENT SHEET
ANGP-T-C-012	1	10/08/13	ALIGNMENT SHEET
ANGP-T-C-013	2	11/13/13	ALIGNMENT SHEET
ANGP-T-C-014	1	10/08/13	ALIGNMENT SHEET

DRAFT - NOT FOR CONSTRUCTION

Revise to be CDL
Page X of 12.

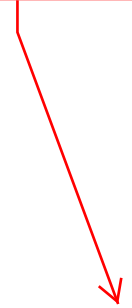

ANGP-T-C-015	2	01/31/14	ALIGNMENT SHEET
ANGP-T-C-016	2	01/31/14	ALIGNMENT SHEET
DWG NO.	REV. NO.	DATE	DRAWING TITLE - CIVIL
ANGP-T-C-017	1	10/08/13	ALIGNMENT SHEET
ANGP-T-C-018	1	10/08/13	ALIGNMENT SHEET
ANGP-T-C-019	1	10/08/13	ALIGNMENT SHEET
ANGP-T-C-020	2	02/03/14	ALIGNMENT SHEET
ANGP-T-C-021	1	10/08/13	ALIGNMENT SHEET
ANGP-T-C-022	1	10/08/13	ALIGNMENT SHEET
ANGP-T-C-023B	1	10/08/13	ALIGNMENT SHEET
ANGP-T-C-024	1	10/08/13	ALIGNMENT SHEET
ANGP-T-C-025	1	10/08/13	ALIGNMENT SHEET
ANGP-T-C-026	1	10/08/13	ALIGNMENT SHEET
ANGP-T-C-027	2	11/13/13	ALIGNMENT SHEET
ANGP-T-C-028	1	10/08/13	ALIGNMENT SHEET
ANGP-T-C-029	2	01/31/14	ALIGNMENT SHEET
ANGP-T-C-030	1	10/08/13	ALIGNMENT SHEET
ANGP-T-C-031	1	10/08/13	ALIGNMENT SHEET
ANGP-T-C-032	2	03/14/14	ALIGNMENT SHEET
ANGP-T-C-033	3	03/14/14	ALIGNMENT SHEET
ANGP-T-C-034	2	01/31/14	ALIGNMENT SHEET
ANGP-T-C-035	2	02/14/14	ALIGNMENT SHEET
ANGP-T-C-036	1	10/08/13	ALIGNMENT SHEET
ANGP-T-C-037	1	10/08/13	ALIGNMENT SHEET
ANGP-T-C-038	1	10/08/13	ALIGNMENT SHEET
ANGP-T-C-039	1	10/08/13	ALIGNMENT SHEET
ANGP-T-C-040	3	01/27/14	ALIGNMENT SHEET
ANGP-T-C-041	1	10/08/13	ALIGNMENT SHEET
ANGP-T-C-042	1	10/08/13	ALIGNMENT SHEET
ANGP-T-C-043	1	10/08/13	ALIGNMENT SHEET
ANGP-T-C-044	3	04/10/14	ALIGNMENT SHEET
ANGP-T-C-045	1	10/08/13	ALIGNMENT SHEET
ANGP-T-C-046	1	10/08/13	ALIGNMENT SHEET
ANGP-T-C-047	2	11/13/13	ALIGNMENT SHEET
ANGP-T-C-048	1	10/08/13	ALIGNMENT SHEET
ANGP-T-C-049	2	02/03/14	ALIGNMENT SHEET
ANGP-T-C-050	2	02/04/14	ALIGNMENT SHEET
ANGP-T-C-051	3	04/25/14	ALIGNMENT SHEET
ANGP-T-C-052	1	10/08/13	ALIGNMENT SHEET
ANGP-T-C-053	1	10/08/13	ALIGNMENT SHEET
ANGP-T-C-054	1	10/08/13	ALIGNMENT SHEET
ANGP-T-C-055	1	10/08/13	ALIGNMENT SHEET
ANGP-T-C-056	2	01/31/14	ALIGNMENT SHEET
ANGP-T-C-057	1	10/08/13	ALIGNMENT SHEET
ANGP-T-C-058	1	10/08/13	ALIGNMENT SHEET

Make sure table title appears on each new page for all tables in CDL.

DRAFT - NOT FOR CONSTRUCTION

ANGP-T-C-059	1	10/08/13	ALIGNMENT SHEET
ANGP-T-C-060	1	10/08/13	ALIGNMENT SHEET
ANGP-T-C-061A	1	10/08/13	ALIGNMENT SHEET
ANGP-T-C-061B	2	02/04/14	ALIGNMENT SHEET
DWG NO.	REV. NO.	DATE	DRAWING TITLE - CIVIL
ANGP-T-C-062	2	02/04/14	ALIGNMENT SHEET
ANGP-T-C-063	2	02/04/14	ALIGNMENT SHEET
ANGP-T-C-064	1	10/08/13	ALIGNMENT SHEET
ANGP-T-C-065	1	10/08/13	ALIGNMENT SHEET
ANGP-T-C-066	2	04/10/14	ALIGNMENT SHEET
ANGP-T-C-067	2	11/13/13	ALIGNMENT SHEET
ANGP-T-C-068	2	11/13/13	ALIGNMENT SHEET
ANGP-T-C-069	1	10/08/13	ALIGNMENT SHEET
ANGP-T-C-070	1	10/08/13	ALIGNMENT SHEET
ANGP-T-C-071	1	10/08/13	ALIGNMENT SHEET
ANGP-T-C-072	2	04/10/14	ALIGNMENT SHEET
ANGP-T-C-073	1	10/08/13	ALIGNMENT SHEET
ANGP-T-C-074	1	10/08/13	ALIGNMENT SHEET
ANGP-T-C-075	1	10/08/13	ALIGNMENT SHEET
ANGP-T-C-076	1	10/08/13	ALIGNMENT SHEET
ANGP-T-C-077	1	10/08/13	ALIGNMENT SHEET
ANGP-T-C-078	1	10/08/13	ALIGNMENT SHEET
ANGP-T-C-079	2	05/08/14	ALIGNMENT SHEET
ANGP-T-C-080	1	10/08/13	ALIGNMENT SHEET
ANGP-T-C-081	1	10/08/13	ALIGNMENT SHEET
ANGP-T-C-082A	1	10/08/13	ALIGNMENT SHEET
ANGP-T-C-082B	1	10/08/13	ALIGNMENT SHEET
ANGP-T-C-083A	1	10/08/13	ALIGNMENT SHEET
ANGP-T-C-083B	1	10/08/13	ALIGNMENT SHEET
ANGP-T-C-084A	1	10/08/13	ALIGNMENT SHEET
ANGP-T-C-084B	1	10/08/13	ALIGNMENT SHEET
ANGP-T-C-085	1	10/08/13	ALIGNMENT SHEET

VERMONT GAS - PROPOSED 12" PIPELINE -
ADDISON NATURAL GAS PROJECT - EPSC SHEETS



DWG NO.	REV. NO.	DATE	DRAWING TITLE - GENERAL
ANGP-T-G-001	1	09/20/13	COVER SHEET
ANGP-T-G-002	1	09/20/13	INDEX SHEET
ANGP-T-G-003	3	11/13/13	LEGEND & NOTES
ANGP-T-G-004	0	06/28/13	CONST. CONFIG. DETAILS
ANGP-T-G-005	1	09/20/13	CONST. CONFIG. DETAILS

ANGP-T-G-006	1	09/20/13	CONST. CONFIG. DETAILS
ANGP-T-G-007A	4	01/31/14	ACCESS ROAD DETAILS
ANGP-T-G-007B	2	02/21/14	ACCESS ROAD DETAILS
ANGP-T-G-008	2	11/13/13	ACCESS ROAD DETAILS
ANGP-T-G-009	4	02/24/14	ACCESS ROAD DETAILS
ANGP-T-G-010	1	01/31/14	ACCESS ROAD DETAILS
DWG NO.	REV. NO.	DATE	DRAWING TITLE - GENERAL
ANGP-T-G-011	2	10/14/13	EPSC NOTES
ANGP-T-G-012	0	06/28/13	CONSTRUCTION DETAILS
ANGP-T-G-013	2	10/14/13	CONSTRUCTION DETAILS
ANGP-T-G-014	0	06/28/13	CONSTRUCTION DETAILS
ANGP-T-G-015	2	10/14/13	CONSTRUCTION DETAILS
ANGP-T-G-016	0	06/28/13	CONSTRUCTION DETAILS
ANGP-T-G-017	2	10/08/13	CONSTRUCTION DETAILS
ANGP-T-G-018	1	09/20/13	CONSTRUCTION DETAILS
ANGP-T-G-019	1	09/20/13	CONSTRUCTION DETAILS
ANGP-T-G-020	1	09/20/13	CONSTRUCTION DETAILS
ANGP-T-G-021	0	06/28/13	STA. & VALVE DETAILS
ANGP-T-G-022	1	11/13/13	WILLISTON PIPEYARD
ANGP-T-G-023	1	TBD	PLANK ROAD PIPEYARD
DWG NO.	REV. NO.	DATE	DRAWING TITLE - EPSC
ANGP-EPSC-001A	1	09/20/13	EPSC PLAN
ANGP-EPSC-001B	1	09/20/13	EPSC PLAN
ANGP-EPSC-002	1	09/20/13	EPSC PLAN
ANGP-EPSC-003	1	09/20/13	EPSC PLAN
ANGP-EPSC-004	1	09/20/13	EPSC PLAN
ANGP-EPSC-005	1	03/26/14	EPSC PLAN
ANGP-EPSC-006	0	06/28/13	EPSC PLAN
ANGP-EPSC-007	0	06/28/13	EPSC PLAN
ANGP-EPSC-008	0	06/28/13	EPSC PLAN
ANGP-EPSC-009	0	06/28/13	EPSC PLAN
ANGP-EPSC-010	0	06/28/13	EPSC PLAN
ANGP-EPSC-011	0	06/28/13	EPSC PLAN
ANGP-EPSC-012	0	06/28/13	EPSC PLAN
ANGP-EPSC-013	0	06/28/13	EPSC PLAN
ANGP-EPSC-014	1	09/20/13	EPSC PLAN
ANGP-EPSC-015	2	01/31/14	EPSC PLAN
ANGP-EPSC-016	2	01/31/14	EPSC PLAN
ANGP-EPSC-017	1	09/20/13	EPSC PLAN
ANGP-EPSC-018	1	09/20/13	EPSC PLAN
ANGP-EPSC-019	1	09/20/13	EPSC PLAN
ANGP-EPSC-020	2	02/04/14	EPSC PLAN
ANGP-EPSC-021	1	09/20/13	EPSC PLAN
ANGP-EPSC-022	0	06/28/13	EPSC PLAN
ANGP-EPSC-023B	2	10/08/13	EPSC PLAN
ANGP-EPSC-024	1	09/20/13	EPSC PLAN

ANGP-EPSC-025	1	09/20/13	EPSC PLAN
ANGP-EPSC-026	1	09/20/13	EPSC PLAN
ANGP-EPSC-027	2	11/13/13	EPSC PLAN
ANGP-EPSC-028	0	06/28/13	EPSC PLAN
ANGP-EPSC-029	2	01/31/14	EPSC PLAN
ANGP-EPSC-030	0	06/28/13	EPSC PLAN
DWG NO.	REV. NO.	DATE	DRAWING TITLE - EPSC
ANGP-EPSC-031	0	06/28/13	EPSC PLAN
ANGP-EPSC-032	1	03/14/14	EPSC PLAN
ANGP-EPSC-033	3	03/14/14	EPSC PLAN
ANGP-EPSC-034	2	01/31/14	EPSC PLAN
ANGP-EPSC-035	2	02/14/14	EPSC PLAN
ANGP-EPSC-036	1	09/20/13	EPSC PLAN
ANGP-EPSC-037	0	06/28/13	EPSC PLAN
ANGP-EPSC-038	1	09/20/13	EPSC PLAN
ANGP-EPSC-039	1	09/20/13	EPSC PLAN
ANGP-EPSC-040	2	02/04/14	EPSC PLAN
ANGP-EPSC-041	0	06/28/13	EPSC PLAN
ANGP-EPSC-042	0	06/28/13	EPSC PLAN
ANGP-EPSC-043	1	09/20/13	EPSC PLAN
ANGP-EPSC-044	2	04/10/14	EPSC PLAN
ANGP-EPSC-045	0	06/28/13	EPSC PLAN
ANGP-EPSC-046	2	10/08/13	EPSC PLAN
ANGP-EPSC-047	3	11/13/13	EPSC PLAN
ANGP-EPSC-048	1	09/20/13	EPSC PLAN
ANGP-EPSC-049	2	02/04/14	EPSC PLAN
ANGP-EPSC-050	2	02/04/14	EPSC PLAN
ANGP-EPSC-051	3	04/25/14	EPSC PLAN
ANGP-EPSC-052	0	06/28/13	EPSC PLAN
ANGP-EPSC-053	0	06/28/13	EPSC PLAN
ANGP-EPSC-054	0	06/28/13	EPSC PLAN
ANGP-EPSC-055	0	06/28/13	EPSC PLAN
ANGP-EPSC-056	2	01/31/14	EPSC PLAN
ANGP-EPSC-057	1	09/20/13	EPSC PLAN
ANGP-EPSC-058	1	09/20/13	EPSC PLAN
ANGP-EPSC-059	1	09/20/13	EPSC PLAN
ANGP-EPSC-060	0	06/28/13	EPSC PLAN
ANGP-EPSC-061A	1	09/20/13	EPSC PLAN
ANGP-EPSC-061B	1	02/04/14	EPSC PLAN
ANGP-EPSC-062	1	02/04/14	EPSC PLAN
ANGP-EPSC-063	1	02/14/14	EPSC PLAN
ANGP-EPSC-064	0	06/28/13	EPSC PLAN
ANGP-EPSC-065	1	09/20/13	EPSC PLAN
ANGP-EPSC-066	2	04/10/14	EPSC PLAN
ANGP-EPSC-067	1	09/20/13	EPSC PLAN
ANGP-EPSC-068	1	09/20/13	EPSC PLAN
ANGP-EPSC-069	0	06/28/13	EPSC PLAN

DRAFT - NOT FOR CONSTRUCTION

ANGP-EPSC-070	0	06/28/13	EPSC PLAN
ANGP-EPSC-071	0	06/28/13	EPSC PLAN
ANGP-EPSC-072	1	04/10/14	EPSC PLAN
ANGP-EPSC-073	0	06/28/13	EPSC PLAN
ANGP-EPSC-074	0	06/28/13	EPSC PLAN
ANGP-EPSC-075	0	06/28/13	EPSC PLAN
DWG NO.	REV. NO.	DATE	DRAWING TITLE - EPSC
ANGP-EPSC-076	0	06/28/13	EPSC PLAN
ANGP-EPSC-077	0	06/28/13	EPSC PLAN
ANGP-EPSC-078	0	06/28/13	EPSC PLAN
ANGP-EPSC-079	1	05/08/14	EPSC PLAN
ANGP-EPSC-080	0	06/28/13	EPSC PLAN
ANGP-EPSC-081	0	06/28/13	EPSC PLAN
ANGP-EPSC-082A	1	09/20/13	EPSC PLAN
ANGP-EPSC-082B	1	09/20/13	EPSC PLAN
ANGP-EPSC-083A	1	09/20/13	EPSC PLAN
ANGP-EPSC-083B	1	09/20/13	EPSC PLAN
ANGP-EPSC-084A	1	09/20/13	EPSC PLAN
ANGP-EPSC-084B	1	09/20/13	EPSC PLAN
ANGP-EPSC-085	0	06/28/13	EPSC PLAN

DRAFT - NOT FOR CONSTRUCTION

COLCHESTER LAUNCHER AND TIE-IN SITE –
ISSUED FOR CONSTRUCTION - DRAWING SET REVISION 1

DWG NO. REV.	REV. NO.	DATE	DRAWING TITLE - MECHANICAL
15-713-G-400	1	09/24/13	COVER SHEET
15-713-G-401	1	09/24/13	P&ID LEGEND
15-713-G-402	1	09/24/13	P&ID
15-713-M-400	1	09/24/13	PIPING PLAN VIEW
15-713-M-401	1	09/24/13	PIPING SECTION VIEWS
15-713-M-402	1	09/24/13	PIPING SECTION VIEWS
15-713-M-403	1	09/24/13	BILL OF MATERIAL
DWG NO.	REV. NO.	DATE	DRAWING TITLE - CIVIL
15-713-C-400	A	06/14/13	GENERAL NOTES AND LEGEND
15-713-C-401	A	06/14/13	GENERAL ARRANGEMENT PLAN
15-713-C-402	A	06/14/13	SITE DETAILS
15-713-C-403	A	06/14/13	SITE DETAILS
DWG NO.	REV. NO.	DATE	DRAWING TITLE - ELECTRICAL
15-713-E-401	1	09/24/13	AREA CLASSIFICATION PLAN
15-713-E-402	0	09/24/13	CONDUIT LAYOUT PLAN
15-713-E-403	0	-	GROUNDING PLAN (PENDING)
15-713-E-404	0	09/24/13	GROUNDING DETAILS
15-713-E-405	0	09/24/13	SPARK GAP & FB107 PANEL DETAILS
15-713-E-406	0	09/24/13	RTU POWER DISTRIBUTION
15-713-E-407	0	09/24/13	FLOBOSS 107 EXPANSION CHASSIS CONTROL SYSTEM SCHEMATIC
15-713-E-408	0	09/24/13	FLOBOSS 107 BASE CHASSIS CONTROL SYSTEM SCHEMATIC
15-713-E-409	0	09/24/13	I/O LIST
15-713-E-410	0	09/24/13	AC/DC CONDUIT SCHEDULE
15-713-E-411	0	09/24/13	SINGLE PHASE PANEL LAYOUT
15-713-E-412	0	09/24/13	I&E EQUIPMENT LIST & DC DISTRIBUTION
15-713-E-413	0	09/24/13	INCOMING SERVICE DETAILS
15-713-E-414	0	09/24/13	BARRIER & ENCLOSURE DETAILS
15-713-E-415	0	-	CATHODIC PROTECTION PLAN (PENDING)
15-713-E-416	0	-	CATHODIC PROTECTION DETAILS(PENDING)

MAINLINE VALVE TYPICAL –
ISSUED FOR BID - DRAWING SET REVISION B

DWG NO. REV.	REV. NO.	DATE	DRAWING TITLE - MECHANICAL
15-713-G-500	B	09/25/13	COVER SHEET
15-713-G-501	B	09/25/13	P&ID LEGEND
15-713-G-502	B	09/25/13	P&ID
15-713-M-500	B	09/25/13	MLV PLAN VIEW, PIPING SECTION VIEW, BILL OF MATERIAL
DWG NO.	REV. NO.	DATE	DRAWING TITLE - CIVIL
15-713-C-500	A	06/14/13	GENERAL NOTES AND LEGEND
15-713-C-501	A	06/14/13	GENERAL ARRANGEMENT PLAN AND SECTION, MLV 1
15-713-C-502	A	06/14/13	GENERAL ARRANGEMENT PLAN AND SECTION, MLV 2
15-713-C-503	A	06/14/13	GENERAL ARRANGEMENT PLAN AND SECTION, MLV 3
15-713-C-504	A	06/26/13	GENERAL ARRANGEMENT PLAN AND SECTION, MLV 4
15-713-C-505	A	06/14/13	GENERAL ARRANGEMENT PLAN AND SECTION, MLV 6
15-713-C-506	A	06/14/13	SITE DETAILS
15-713-C-507	A	06/14/13	SITE DETAILS
DWG NO.	REV. NO.	DATE	DRAWING TITLE - ELECTRICAL
15-713-E-500	B	09/25/13	MLV AREA CLASSIFICATION PLAN
15-713-E-501	B	09/25/13	MLV CONDUIT LAYOUT PLAN
15-713-E-503	A	-	MLV GROUNDING PLAN (PENDING)
15-713-E-504	A	06/28/13	GROUNDING DETAILS
15-713-E-505	A	06/28/13	SPARK GAP & FB107 PANEL DETAILS
15-713-E-506	A	06/28/13	RTU POWER DISTRIBUTION
15-713-E-507	A	06/28/13	FLOBOSS 107 EXPANSION CHASSIS CONTROL SYSTEM SCHEMATIC
15-713-E-508	A	06/28/13	FLOBOSS 107 EXPANSION CHASSIS CONTROL SYSTEM SCHEMATIC
15-713-E-509	A	06/28/13	I/O LIST
15-713-E-510	B	07/04/13	AC/DC CONDUIT SCHEDULE
15-713-E-511	A	06/28/13	SINGLE PHASE PANEL LAYOUT
15-713-E-512	A	06/28/13	I&E EQUIPMENT LIST & DC DISTRIBUTION
15-713-E-513	A	06/28/13	INCOMING SERVICE DETAILS
15-713-E-514	A	06/28/13	BARRIER & ENCLOSURE DETAILS
15-713-E-515	A	-	CATHODIC PROTECTION PLAN (PENDING)
15-713-E-516	A	-	CATHODIC PROTECTION DETAILS(PENDING)

DRAFT - NOT FOR CONSTRUCTION

WILLISTON METER & REGULATION STATION – ISSUED
FOR CONSTRUCTION – DRAWING SET REVISION 3

DWG NO.	REV. NO.	DATE	DRAWING TITLE - MECHANICAL
15-713-G-100	3	09/25/13	COVER SHEET
15-713-G-102	1	09/25/13	P&ID LEGEND
15-713-G-103	1	09/25/13	P&ID
15-713-M-100	2	09/25/13	PIPING PLAN VIEW
15-713-M-101	1	09/25/13	PIPING SECTION VIEWS
15-713-M-102	1	09/25/13	PIPING SECTION VIEWS
15-713-M-103	1	09/25/13	PIPING SECTION VIEWS
15-713-M-104	1	09/25/13	MECHANICAL DETAILS
15-713-M-105	2	09/25/13	BILL OF MATERIAL (SHEET 1 OF 2)
15-713-M-105	2	09/25/13	BILL OF MATERIAL (SHEET 2 OF 2)
15-713-M-106	1	09/25/13	METER AND REGULATOR BUILDING
15-713-M-107	1	09/25/13	DAC BUILDING
DWG NO. REV.	REV. NO.	DATE	DRAWING TITLE - CIVIL
15-713-G-101	0	03/05/13	GENERAL NOTES AND LEGEND
15-713-C-100	0	-	GENERAL ARRANGEMENT PLAN
15-713-C-101	0	-	SITE DETAILS
15-713-C-102	0	03/05/13	SITE DETAILS
S-001	-	-	STRUCTURAL NOTES
S-101	-	-	PRECAST BUILDING FOUNDATIONS
DWG NO.	REV. NO.	DATE	DRAWING TITLE - ELECTRICAL
15-713-E-101	2	09/25/13	AREA CLASSIFICATION PLAN
15-713-E-102	1	04/10/13	CONDUIT LAYOUT PLAN
15-713-E-103	0	-	GROUNDING PLAN (PENDING)
15-713-E-104	0	04/01/13	GROUNDING DETAILS
15-713-E-105	0	04/01/13	SPARK GAP & FB107 PANEL DETAILS
15-713-E-106	0	04/01/13	RTU POWER DISTRIBUTION
15-713-E-107	0	04/01/13	FLOBOSS 107 EXPANSION CHASSIS CONTROL SYSTEM SCHEMATIC
15-713-E-108	0	04/01/13	FLOBOSS 107 BASE CHASSIS CONTROL SYSTEM SCHEMATIC
15-713-E-109	0	04/01/13	I/O LIST
15-713-E-110	0	04/01/13	AC/DC CONDUIT SCHEDULE
15-713-E-111	0	04/01/13	SINGLE PHASE PANEL LAYOUT
15-713-E-112	0	04/01/13	I&E EQUIPMENT LIST & DC DISTRIBUTION
15-713-E-113	0	04/01/13	INCOMING SERVICE DETAILS
15-713-E-114	0	04/01/13	BARRIER & ENCLOSURE DETAILS
15-713-E-115	0	-	CATHODIC PROTECTION PLAN (PENDING)
15-713-E-116	0	-	CATHODIC PROTECTION DETAILS(PENDING)

PLANK ROAD METER AND REGULATION STATION –
ISSUED FOR CONSTRUCTION - DRAWING SET REVISION 2

DWG NO. REV.	REV. NO.	DATE	DRAWING TITLE - MECHANICAL
15-713-G-200	2	09/24/13	COVER SHEET
15-713-G-202	0	04/01/13	P&ID LEGEND
15-713-G-203	1	09/24/13	P&ID
15-713-M-200	1	09/24/13	PIPING PLAN VIEW
15-713-M-201	1	09/24/13	PIPING SECTION VIEWS
15-713-M-202	1	09/24/13	PIPING SECTION VIEWS
15-713-M-203	1	09/24/13	PIPING SECTION VIEWS
15-713-M-204	1	09/24/13	PIPING SECTION VIEWS
15-713-M-205	0	04/01/13	MECHANICAL DETAILS
15-713-M-206	1	09/24/13	BILL OF MATERIAL (SH. 1 OF 2)
15-713-M-206	1	09/24/13	BILL OF MATERIAL (SH. 2 OF 2)
15-713-M-207	0	04/01/13	METER AND REGULATOR BUILDING
15-713-M-208	0	04/01/13	DAC BUILDING
DWG NO.	REV. NO.	DATE	DRAWING TITLE - CIVIL
15-713-G-201	0	05/03/13	GENERAL NOTES AND LEGEND
15-713-C-200	0	-	GENERAL ARRANGEMENT PLAN
15-713-C-201	0	-	SITE DETAILS
15-713-C-202	0	05/03/13	SITE DETAILS
S-001	-	-	STRUCTURAL NOTES
S-101	-	-	PRECAST BUILDING FOUNDATIONS
DWG NO.	REV. NO.	DATE	DRAWING TITLE - ELECTRICAL
15-713-E-201	1	09/24/13	AREA CLASSIFICATION PLAN
15-713-E-202	1	09/24/13	CONDUIT LAYOUT PLAN
15-713-E-203	0	-	GROUNDING PLAN (PENDING)
15-713-E-204	0	04/01/13	GROUNDING DETAILS
15-713-E-205	0	04/01/13	SPARK GAP & FB107 PANEL DETAILS
15-713-E-206	0	04/01/13	RTU POWER DISTRIBUTION
15-713-E-207	0	04/01/13	FLOBOSS 107 BASE CHASSIS CONTROL SYSTEM SCHEMATIC
15-713-E-208	0	04/01/13	FLOBOSS 107 EXPANSION CHASSIS CONTROL SYSTEM SCHEMATIC
15-713-E-209	0	04/01/13	I/O LIST
15-713-E-210	1	07/04/13	AC/DC CONDUIT SCHEDULE
15-713-E-211	0	04/01/13	SINGLE PHASE PANEL LAYOUT
15-713-E-212	0	04/01/13	I&E EQUIPMENT LIST & DC DISTRIBUTION
15-713-E-213	0	04/01/13	INCOMING SERVICE DETAILS
15-713-E-214	0	04/01/13	BARRIER & ENCLOSURE DETAILS
15-713-E-215	0	-	CATHODIC PROTECTION PLAN (PENDING)
15-713-E-216	0	-	CATHODIC PROTECTION DETAILS(PENDING)

DRAFT NOT FOR CONSTRUCTION

MIDDLEBURY METER AND REGULATION STATION – ISSUED FOR CONSTRUCTION -
DRAWING SET REVISION 2

DWG NO. REV.	REV. NO.	DATE	DRAWING TITLE - MECHANICAL
15-713-G-300	2	09/24/13	COVER SHEET
15-713-G-302	1	09/24/13	P&ID LEGEND
15-713-G-303	1	09/24/13	P&ID
15-713-M-301	1	09/24/13	PIPING GENERAL ARRANGEMENT
15-713-M-302	1	09/24/13	PIPING SECTION VIEWS
15-713-M-303	1	09/24/13	PIPING SECTION VIEWS
15-713-M-304	1	09/24/13	PIPING SECTION VIEWS
15-713-M-305	1	09/24/13	MAINLINE VALVE ELEVATION
15-713-M-306	1	09/24/13	MECHANICAL DETAILS
15-713-M-307	1	09/24/13	BILL OF MATERIAL (SHT. 1 OF 2)
15-713-M-307	1	09/24/13	BILL OF MATERIAL (SHT. 2 OF 2)
15-713-M-308	0	04/01/13	METER AND REGULATOR BUILDING
15-713-M-309	0	04/01/13	DAC BUILDING

DWG NO. REV.	REV. NO.	DATE	DRAWING TITLE - CIVIL
15-713-G-301	0	-	GENERAL NOTES AND LEGEND
15-713-C-300	0	-	GENERAL ARRANGEMENT PLAN
15-713-C-301	0	-	SITE DETAILS
15-713-C-302	0	-	SITE DETAILS
S-001	-	-	STRUCTURAL NOTES
S-101	-	-	PRECAST BUILDING FOUNDATIONS

DWG NO. REV.	REV. NO.	DATE	DRAWING TITLE - ELECTRICAL
15-713-E-301	1	09/24/13	AREA CLASSIFICATION PLAN
15-713-E-302	1	09/20/13	CONDUIT LAYOUT PLAN
15-713-E-303	0	-	GROUNDING PLAN (PENDING)
15-713-E-304	0	04/01/13	GROUNDING DETAILS
15-713-E-305	0	04/01/13	SPARK GAP & FB107 PANEL DETAILS
15-713-E-306	0	04/01/13	RTU POWER DISTRIBUTION
15-713-E-307	0	04/01/13	FLOBOSS 107 BASE CHASSIS CONTROL SYSTEM SCHEMATIC
15-713-E-308	0	04/01/13	FLOBOSS 107 EXPANSION CHASSIS CONTROL SYSTEM SCHEMATIC
15-713-E-309	0	04/01/13	I/O LIST
15-713-E-310	0	04/01/13	AC/DC CONDUIT SCHEDULE
15-713-E-311	0	04/01/13	SINGLE PHASE PANEL LAYOUT
15-713-E-312	0	04/01/13	I&E EQUIPMENT LIST & DC DISTRIBUTION
15-713-E-313	0	04/01/13	INCOMING SERVICE DETAILS
15-713-E-314	0	04/01/13	BARRIER & ENCLOSURE DETAILS
15-713-E-315	0	-	CATHODIC PROTECTION PLAN (PENDING)
15-713-E-316	0	-	CATHODIC PROTECTION DETAILS (PENDING)

ARK ENGINEERING – AC MITIGATION SYSTEM DRAWINGS,
PROJECT NO. 12-E-144-AC REVISION 2

DWG NO.	SHEETS	REV. NO.	DATE	DRAWING TITLE
12144-101	1	2	09/30/13	COVER SHEET
12144-205	1	2	09/30/13	GROUNDING PLAN - WILLISTON M & R
12144-206	1	2	09/30/13	GROUNDING PLAN - MLV-2
12144-207	1	2	09/30/13	GROUNDING PLAN - MLV-3
12144-208	1	2	09/30/13	GROUNDING PLAN - MLV-4
12144-209	1	2	09/30/13	GROUNDING PLAN - MLV-5/PLANK ROAD M & R
12144-210	1	2	09/30/13	GROUNDING PLAN - MLV-6
12144-211	1	2	09/30/13	GROUNDING PLAN - COLCHESTER LAUNCHER
12144-212	1	2	09/30/13	GROUNDING PLAN - MIDDLEBURY M & R
12144-305	1	2	09/30/13	GROUND LOOP SPACE CONNECTION DETAILS
12144-306	1	2	09/30/13	CABLE TO PIPELINE CONNECTION DETAILS
12144-307	1	2	09/30/13	SOLID STATE DECOUPLER (SSD) INSTALLATION DETAILS
12144-308	1	2	09/30/13	FENCE & GATE CLAMP CONNECTION DETAILS
12144-309	1	2	09/30/13	GROUND ROD INSTALLATION DETAILS - DRILL PROCEDURE
12144-401	2	2	09/30/13	MATERIALS LIST

ARK ENGINEERING – CATHODIC PROTECTION SYSTEM
DESIGN DRAWINGS, PROJECT NO. 12-E-145-CP REVISION 0

DWG NO.	SHEETS	REV. NO.	DATE	DRAWING TITLE
12145-101	1	0	10/04/13	COVER SHEET
12145-203	1	0	10/04/13	CATHODIC PROTECTION - COLCHESTER LAUNCHER SITE
12145-204	1	0	10/04/13	CATHODIC PROTECTION - WILLISTON M & R STATION
12145-205	1	0	10/04/13	CATHODIC PROTECTION - PLANK ROAD M & R STATION
12145-206	1	0	10/04/13	CATHODIC PROTECTION - MIDDLEBURY M & R STATION
12145-304	1	0	10/04/13	CABLE TO PIPELINE CONNECTION DETAILS
12145-305	1	0	09/30/13	EXOTHERMIC WELD CONNECTIONS
12145-306	1	0	10/04/13	TEST STATION I - 4 MAGNESIUM ANODE INSTALLATION
12145-307	1	0	10/04/13	TEST STATION II - 2 MAGNESIUM ANODE INSTALLATION
12145-308	1	0	10/04/13	SOLID STATE DECOUPLER (SSD) INSTALLATION DETAILS
12145-401	1	0	10/04/13	MATERIALS LIST

ADD Ark Engineering Zinc Ribbon Drawings Table.

INVITATION TO BID

To Whom It May Concern:

You are invited to submit a bid for general construction of PROPOSED ADDISON NATURAL GAS PROJECT – TRANSMISSION MAIN. A mandatory pre-bid meeting is scheduled for 1:30 p.m. on October 8, 2013.

All bids shall be submitted by e-mail with all required documents and information attached and properly email addressed to CHA Tech Services (Tim Peer at tpeer@chacompanies.com) and Vermont Gas Systems, Inc. (“VGS”, the “Company” or “OWNER” @ cpughe@vermontgas.com) no later than 2:00 pm on November 20, 2013. Three (3) hard copies with original signatures must then be sent to and received by CHA Technical Services no later than 5:00 pm the next business day. Sealed bids are to be sent to: Mr. Tim Peer, Project Manager, CHA, P.O. Box 498 Hinesburg, Vermont 05461. Faxed bids will not be accepted.

During the Bidding Period, questions will be taken up to December 4 at 2:00 p.m. Questions must be submitted on the Contractor’s letterhead and emailed to: Tim Peer at tpeer@chacompanies.com. Responses will be distributed to all bidders.

The work site is located primarily along transportation and utility corridors starting in Colchester and ending in Middlebury, Vermont.

The work includes providing all labor, materials, machinery, tools, equipment and other means of construction necessary and incidental to the completion of the Work shown on the Drawings and described in the Specifications including, but not necessarily limited to the following: The installation of approximately 217,700 linear feet of 12-inch gas transmission piping, mainline valve sites, access roads, and associated required work and appurtenances listed and described within the Project Manual.

All bids must be made on the official Bid Form or an exact copy and first emailed and then enclosed in a sealed envelope to be delivered as detailed above. This is a lump sum bid with additional work items as described in the Instructions To Bidders. This bid shall remain valid for a period of sixty (60) days from the bid due date.

The successful bidder will be required to furnish construction performance and payment bonds for the full contract price.

The successful bidder will be required to comply with all provisions of the Equal Employment Opportunity clauses issued by the United States Secretary of Labor on May 21, 1968 and published in the Federal Register (41CFR Part 60-1, 33 F.2 7804).

No Bidder, or any Contractor awarded the Work, shall under any circumstances use the “Vermont Gas Systems, Inc.” or “VGS” name or logos in advertising, marketing materials, printed matter, listed as a reference, or in any other way that could be construed as advertising (e.g., memo pads, tee shirts, binders, reference list, etc.) without prior written authorization from VGS.

VGS reserves the right to reject any and all Bids, to waive any and all informalities and to disregard all nonconforming, incomplete, untimely, non-responsive or conditional Bids.

OWNER:

Vermont Gas Systems, Inc.
85 Swift Street
South Burlington, VT 05403

CONSTRUCTION MANAGER

TBD

ENGINEER

CHA
III Winners Circle
Albany, NY 12205

INSTRUCTIONS TO BIDDERS

PROJECT IDENTIFICATION:

- a) Project Title: ADDISON NATURAL GAS PROJECT – TRANSMISSION MAIN
- b) Owner: Vermont Gas Systems, Inc.
85 Swift Street
South Burlington, VT 05403
- c) ENGINEER: CHA
III Winners Circle
Albany, New York 12205
Phone: (518) 453-4500
- d) CONSTRUCTION MANAGER: TBD

<u>Paragraph</u>	<u>INDEX</u>	<u>Page</u>
1.	<i>Defined Term</i> _____	2
2.	<i>Copies of Bidding Documents</i> _____	2
3.	<i>Qualification of Bidders</i> _____	2
4.	<i>Examination of Contract Documents and Site</i> _____	2
5.	<i>Availability of Lands for Work, etc.</i> _____	3
6.	<i>Interpretations and Addenda</i> _____	3
7.	<i>Contract Times</i> _____	4
8.	<i>Substitute and “Or-Equal” Items</i> _____	4
9.	<i>Subcontractors, Suppliers, and Others</i> _____	4
10.	<i>Bid Form</i> _____	4
11.	<i>Submission of Bids</i> _____	5
12.	<i>Modification and Withdrawal of Bids</i> _____	5
13.	<i>Opening of Bids</i> _____	5
14.	<i>Bids to Remain Subject to Acceptance</i> _____	5
15.	<i>Award of Contract</i> _____	5
16.	<i>Contract Security</i> _____	6
17.	<i>Signing of Agreement</i> _____	6
18.	<i>Prebid Conference</i> _____	6
19.	<i>OWNER Retainage</i> _____	6
20.	<i>Contracts for Materials</i> _____	6
21.	<i>VGS Specific Requirements</i> _____	6

1. Defined Terms.

Terms used in these Instructions to Bidders which are defined in the General Conditions of the Project Manual have the meanings assigned to them in the General Conditions.

Certain additional terms used in these Instructions to Bidders have the meanings indicated below which are applicable to both the singular and plural thereof.

1.1 **Bidder** - a Contractor who submits a Bid directly to OWNER as distinct from a sub-bidder, who submits a bid to a Bidder.

1.2 **Issuing Office** - the office from which the Bidding Documents are to be issued and where the bidding procedures are to be administered.

1.3 **Successful Bidder** - the lowest, responsible and responsive Bidder to whom OWNER (on the basis of OWNER's evaluation as hereinafter provided, and in OWNER's sole discretion) makes and award.

2. Copies of Bidding Documents

2.1 Complete sets of the Bidding Documents will be provided electronically on the project collaboration website to CONTRACTORS invited to submit a bid. Bids received from Contractors other than those invited will not be accepted.

2.2 Complete sets of Bidding Documents must be used in preparing Bids; neither OWNER nor ENGINEER assume any responsibility for errors or misinterpretations resulting from the use of incomplete sets of Bidding Documents.

2.3 OWNER and ENGINEER make copies of Bidding Documents available only for the purpose of obtaining Bids for the Work and do not thereby confer a license or grant permission for any other use of the Bidding Documents.

3. Qualification of Bidders

To demonstrate qualifications to perform the Work, each Bidder must be prepared to submit within five days after Bid opening upon OWNER's request detailed written evidence such as financial data, previous experience, present commitments and other such data and information as may be called for below (or in the Supplementary Instructions). Each Bid must

contain evidence of the Bidder's qualification to do business in Vermont.

4. Examination of Contract Documents and Site.

4.1 It is the responsibility of each Bidder before submitting a Bid:

4.1.1 To examine thoroughly the Contract Documents and other related data identified in the Bidding Documents (including "technical data" referred to below);

4.1.2 To visit the site to become familiar with and satisfy Bidder as to the general, local and site conditions that may affect cost, progress, performance, or furnishing of the Work;

4.1.3 To consider all federal, state, and local Laws and Regulations that may affect cost, progress, performance or furnishing of the Work;

4.1.4 To study and carefully correlate Bidder's knowledge and observations with the Contract Documents and other related documents and data; and

4.1.5 To promptly notify ENGINEER of all conflicts, errors, ambiguities or discrepancies which Bidder has discovered in or between the Contract Documents and other related documents and data.

4.2 Reference is made to the Supplementary Conditions for identification of:

4.2.1 Those reports of explorations and tests of subsurface conditions at or contiguous to the site which have been utilized by ENGINEER in preparation of the Contract Documents. Bidder may rely upon the general accuracy of the "technical data" contained in such reports but not upon other data, interpretations, opinions or information contained in such reports or otherwise relating to the subsurface conditions at the site, nor upon the completeness thereof for the purposes of bidding or construction.

4.2.2 Those drawings of physical conditions in or relating to existing surface and subsurface structures (except Underground Facilities) which are at or contiguous to the site that have been utilized by ENGINEER in preparation of the Contract Documents.

Bidder may rely upon the general accuracy of the "technical data" contained in such drawings but not upon other data, interpretations, opinions, or information shown or indicated in such drawings or

otherwise relating to such structures, nor upon the completeness thereof for the purposes of bidding or construction.

Copies of such reports and drawings will be made available by OWNER to any Bidder on request. Those reports and drawings are not part of the Contract Documents, but the "technical data" contained therein upon which Bidder is entitled to rely as provided in Paragraph 4.2 of the General Conditions has been identified and established in Paragraph SC-4.2 of the Supplementary Conditions. Bidder is responsible for any interpretation or conclusion drawn from any "technical data" or any such data, interpretations, opinions, or information.

4.3 Information and data shown or indicated in the Contract Documents with respect to existing Underground Facilities at or contiguous to the site is based upon information and data furnished to OWNER and ENGINEER by OWNERS of such Underground Facilities or others, and the OWNER and ENGINEER do not assume responsibility for the accuracy or completeness thereof unless it is expressly provided otherwise in the Supplementary Conditions.

4.4 Provisions concerning responsibilities for the adequacy of data furnished to prospective Bidders with respect to subsurface conditions, other physical conditions and Underground Facilities, and possible changes in the Contract Documents due to differing or unanticipated conditions appear in Paragraphs 4.2 and 4.3 of the General Conditions.

4.5 Before submitting a Bid each Bidder will be responsible to obtain such additional or supplementary examinations, investigations, explorations, tests, studies, and data concerning conditions (surface, subsurface, and Underground Facilities) at or contiguous to the site or otherwise, which may affect cost, progress, performance or furnishing of the Work or which relate to any aspect of the means, methods, techniques, sequences or procedures of construction to be employed by Bidder and safety precautions and programs incident thereto or performing and furnishing the Work in accordance with the time, price, and other terms and conditions of the Contract Documents.

4.6 On request, OWNER will provide each Bidder access to the site to conduct such examinations, investigations, explorations, tests, and studies as each Bidder deems necessary for submission of a Bid. Bidder must fill all holes and clean up and restore the site to its former conditions upon completion of such explorations, investigations, tests, and studies.

4.7 Reference is made to the Supplementary Conditions for the identification of the general nature of work that is to be performed at the site by OWNER or others (such as utilities and other prime contractors) that relates to the work for which a Bid is to be submitted. On request, OWNER will provide to each Bidder for examination access to or copies of pertinent portions of the contract documents (other than portions thereof related to price) for such work.

4.8 The submission of a Bid will constitute an incontrovertible representation by Bidder that Bidder has complied with every requirement of this Article 4, that without exception the Bid is premised upon performing and furnishing the Work required by the Contract Documents and applying the specific means, methods, techniques, sequences, or procedures for construction (if any) that may be shown or indicated or expressly required by the Contract Documents, that the Bidder has given ENGINEER written notice of all conflicts, errors, ambiguities and discrepancies that Bidder has discovered in the Contract Documents, and the Contract documents are generally sufficient to indicate and convey understanding of all terms and conditions for performing and furnishing the Work.

4.9 The provisions of this Article do not apply to Asbestos, Polychlorinated biphenyls (PCBs), Petroleum, Hazardous Waste, or Radioactive Material covered by Paragraph 4.5 of the General Conditions.

5. Availability of Lands for Work, etc.

The lands upon which the Work is to be performed, rights-of-way and easements for access thereto and other lands designated for use by the Successful Bidder in performing the Work are identified in the Contract Documents. All additional land and access thereto required for temporary construction facilities, construction equipment, or storage of materials and equipment to be incorporated in the Work are to be obtained and paid for by Successful Bidder. Easements for permanent structures or permanent changes in existing facilities are to be obtained and paid for by OWNER unless otherwise provided in the Contract Documents.

6. Interpretations and Addenda.

6.1 All questions about the meaning or intent of the Bidding Documents are to be directed to ENGINEER. Interpretations or clarifications considered necessary by ENGINEER in response to such questions will be issued by Addenda mailed or delivered to all parties that were recorded by ENGINEER as having received the Bidding Documents. Questions received less than seven (7) days prior to the date for opening of Bids

may not be answered. Only questions answered by formal written Addenda will be binding. Oral and other interpretations or clarifications not incorporated into formal written Addenda will be without legal effect.

6.2 Addenda may also be issued to modify the Bidding Documents as deemed advisable by OWNER or ENGINEER.

6.3 Addenda cannot be issued after bid opening.

7. Contract Times.

The number of days within which, or the dates by which, the Work is to be substantially completed and also completed and ready for final payment (the term "Contract Times" is defined in paragraph 1.12 of the General Conditions) are set forth in the Agreement (or incorporated therein by reference to the attached Bid Form).

8. Substitute and "Or-Equal" Items.

The Contract, if awarded, will be for the provision of the exact materials and equipment described and specified in the Drawings and Specifications without consideration of possible substitute or "or-equal" items. Whenever it is indicated in the Drawings or Specifications that a substitute or an "or-equal" item of material or equipment may be furnished or used by Contractor if acceptable to ENGINEER, application for such acceptance will not be considered by ENGINEER until after the Effective Date of the Agreement. The procedure for submission of any such application by a Successful Bidder and consideration by ENGINEER is set forth in Paragraphs 6.7.1, 6.7.2 and 6.7.3 of the General Conditions and may be supplemented in the General Requirements.

9. Subcontractors, Suppliers, and Others

9.1 If the Supplementary Conditions require the identity of certain Subcontractors, Suppliers and other persons and organizations (including those who are to furnish the material and equipment) to be submitted to OWNER in advance of a specified date prior to the Effective Date of the Agreement, the apparent or prospective Successful Bidder, and any other Bidder(s) so requested, shall within five days after Bid opening submit to OWNER a list of all such Subcontractors, Suppliers, and other persons and organizations proposed for those portions of the Work for which such identification is required. Such list shall be accompanied by an experience statement with pertinent information regarding similar projects and other evidence of the qualifications of each such

Subcontractor, Supplier, person or organization. If OWNER or ENGINEER has objection to any proposed Subcontractor, Supplier, other persons or organization, OWNER or ENGINEER may before any Notice of Award, request any apparent or prospective Successful Bidder to submit an acceptable substitute in which case the apparent or prospective Successful Bidder shall submit any acceptable substitute without an increase in Bid Price or time for completion or other changes to the Bid or Contract Documents.

If the apparent or prospective Successful Bidder declines to make any such substitution, OWNER may award the Agreement to construct the project to the next lowest Bidder that proposes to use acceptable Subcontractors, Suppliers, and other persons and organizations. The act of declining to make requested substitutions will not constitute grounds for sacrificing the Bid security of any Bidder. Any Subcontractor, Supplier, other person or organization listed and to whom OWNER or ENGINEER does not make written objection prior to the Notice of Award will be deemed acceptable to OWNER and ENGINEER subject to revocation of such acceptance after the Effective Date of the Agreement as provided in paragraph 6.8.2 of the General Conditions.

11.2 The prospective or apparent Successful Bidder, prior to the Notice of Award, shall identify in writing to OWNER those portions of the Work that Such Bidder proposes to subcontract and after the Notice of Award may only subcontract other portions of the Work with OWNER's written consent.

11.3 No Successful Bidder shall be required to employ any Subcontractor, Supplier, other person or organization against whom or which Successful Bidder has good and reasonable grounds for objection.

10. Bid Form.

10.1 The Bid Form is included with the Bidding Documents.

10.2 All blanks on the Bid Form must be completed by printing in black ink or by typewriter.

10.3 Bids by corporations must be executed in the corporate name by a duly-authorized corporate officer and the secretary or an assistant secretary must attest to the authority of the officer to sign. The corporate address and state of incorporation must be shown below the signature. In the case of a limited liability corporation, the manager or member must sign and the secretary or assistant secretary must attest to the authority of the officer to sign.

10.4 Bids by partnerships must be executed in the partnership name and signed by the general of managing partner or by an authorized partner, whose title must appear under the signature and the official address of the partnership must be shown below the signature.

10.5 All names must be typed or printed in black ink below the signature.

10.6 The Bid shall contain an acknowledgment of receipt of all Addenda, the numbers of which must be filled in on the Bid Form.

10.7 The address and telephone number for communications regarding the Bid must be shown.

10.8 Evidence of authority to conduct business as an out-of-state business entity in Vermont shall be provided in accordance with Paragraph 3 above.

11. Submission of Bids.

Bids shall be submitted in the manner and at the times and places indicated in the Invitation to Bid and, when mailed, shall be enclosed in an opaque sealed envelope, marked with the Project title (and, if applicable, the designated portion of the Project for which the Bid is submitted) and the name and address of Bidder, and must be accompanied by the Bid Security and other required documents. If the Bid is sent through the mail or other delivery system the sealed envelope shall be enclosed in a separate envelope with the notation "BID ENCLOSED" on the face of it.

12. Modification and Withdrawal of Bids.

12.1 Bids may be modified or withdrawn by an appropriate document duly executed (in the manner that a Bid must be executed) and delivered to the place where Bids are to be submitted at any time prior to the opening of Bids.

12.2 If, within twenty-four hours after Bids are opened, any Bidder files a duly signed, written notice with OWNER and promptly thereafter demonstrates to the reasonable satisfaction of OWNER that there was a material and substantial mistake in the preparation of its Bid, that bidder may withdraw its Bid and bid security will be returned. Thereafter, that Bidder will be disqualified from further bidding on the Work to be provided under the Contract Documents.

13. Opening of Bids.

Bids will be privately opened.

14. Bids to Remain Subject to Acceptance.

All Bids will remain subject to acceptance for sixty (60) days after the day of the Bid opening, but OWNER may, in its sole discretion, release any Bid and return the Bid Security prior to that date.

15. Award of Contract.

15.1 OWNER reserves the right to reject any or all Bids including, without limitation, the rights to reject any or all nonconforming, non-responsive, unbalanced, or conditional Bids and the right to reject any Bid if OWNER believes that it would not be in OWNER's interest or in the best interest of its ratepayers and program participants or in the best interest of the Project to make an award to that Bidder. OWNER also reserves the right to waive all informalities not involving price, time, or changes in the Work and to negotiate contract terms with the Successful Bidder. Discrepancies between the multiplication of units of Work and unit prices will be resolved in favor of the unit prices. Discrepancies between the indicated sum of any column of figures and the correct sum thereof will be resolved in favor of the correct sum. Discrepancies between words and figures will be resolved in favor of the words.

15.2 In evaluating Bids, OWNER will consider the qualifications of Bidders, whether or not the Bids comply with the prescribed requirements, and such alternates, unit prices and other data, as may be requested in the Bid Form or prior to the Notice of Award.

15.3 OWNER may consider the qualifications and experience of Subcontractors, Suppliers, and other persons and organizations proposed for use in the Project. OWNER also may consider the operating costs, maintenance requirements, performance data and guarantees of major item of materials and equipment proposed for incorporation in the Work.

15.4 OWNER may conduct such investigations as OWNER deems necessary to assist in the evaluation of any Bid and to establish the responsibility, qualifications, and financial ability of Bidders, proposed Subcontractors, Suppliers, and other persons and organizations to perform and furnish the Work in accordance with the Contract Documents to OWNER's satisfaction and within the prescribed time.

15.5 If the contract to construct the Project is to be awarded, it will be awarded to Bidder that OWNER believes, in its sole discretion, will perform the Work in a manner that is in the best interests of the OWNER, its ratepayers, program participants, and/or the Project.

15.6 If the contract to construct the Project is to be awarded, OWNER will give Successful Bidder a Notice of Award within sixty (60) days after the day of the Bid opening.

15.7 OWNER reserves the right to exercise any of the following options, in its sole discretion:

15.7.1 Award no contract award for any of the services described within this Bid.

15.7.2 Award all services to construct the Project to one Bidder.

15.7.3 Issue contract awards for any combination of services and Bidders, as OWNER sees fit.

15.7.4 OWNER is not obligated to accept the lowest price; however, price may be considered as an important criterion. Bidders should base their prices on real costs and not on any limits or price ceilings provided in this Bid.

15.7.5 OWNER reserves the right to reject any or all Bids, to waive technicalities or irregularities, and to accept any Bid it determines to be in the best interest of OWNER, its ratepayers, and program participants and/or the Project.

15.7.6 The acceptance of any Bid or revocation of the Notice of Award prior to the execution of a final Agreement shall not in any way cause VGS to incur any liability or obligation to Bidder, financial, or otherwise.

15.7.7 OWNER has no obligation to reveal the basis for contract award or to provide any information to Bidders relative to the evaluation or decision making process. All participating Bidders will be notified promptly of acceptance or rejection of their Bid(s).

16. Contract Security.

The Supplementary Conditions sets forth OWNER's requirements as to performance and payment Bonds. When the Successful Bidder delivers the executed Agreement to OWNER, it must be accompanied by the required performance and payment Bonds.

17. Signing of Agreement.

When OWNER gives a Notice of Award to the Successful Bidder, it will be accompanied by the required number of unsigned counterparts of the Agreement with all other written Contract Documents attached. Within fifteen days thereafter Successful Bidder shall sign and deliver the required number of counterparts of the Agreement and attached documents to OWNER with the required Bonds. Provided the Notice of Award is not sooner revoked, within ten days thereafter OWNER shall deliver one fully signed counterpart to the Successful Bidder. Each counterpart is to be accompanied by a complete set of the Drawings with appropriate identification.

18. Prebid Conference.

A mandatory prebid conference will be held at 1:30 p.m. on the 8th day of October, 2013 at the following address: Comfort Suites, Sunset Ballroom, 1712 Shelburne Road, South Burlington, 05403. Representatives of OWNER and ENGINEER will be present to discuss the Project. Bidders are required to attend and participate in the conference. ENGINEER will transmit to all prospective Bidders of record such Addenda as ENGINEER considers necessary in response to questions arising at the conference. Oral statements may not be relied upon and will not be binding or legally effective.

19. OWNER Retainage

Provisions concerning retainage and rights to retainage or deposit securities are set forth in the Agreement.

20. Contracts for Materials.

OWNER will execute contracts for the purchase of pipe materials and other materials described in the Project Manual and on the Project Plans.

The materials and equipment provided for in these contracts are to be furnished by the OWNER. The Successful Bidder shall have the materials delivered to the Project site for installation by CONTRACTOR.

21. OWNER Specific Requirements

21.1 Operator Qualification Requirements:

OWNER requires that all Contractors meet the requirements for any covered tasks performed per the Northeast Gas Association (NGA) / VGS Operator Qualification written plan. All Contractors must be qualified under the NGA Operator Qualification Plan. OWNER recommends that Contractors become

members of the NGA for training and certification purposes. Contractor shall comply with the following items:

1. Prior to contract execution: Contractor shall provide a written plan to conform to Operator Qualification requirements when work commences.
2. Prior to start of work: Contractor shall submit Operator Qualification documentation for all persons associated with execution of the work. Any new persons added to crews throughout the execution of the work shall have their Operator Qualification documentation submitted prior to commencing activities associated with the project.

21.2 Drug, Alcohol, and Substance Abuse Testing Compliance:

OWNER and its Contractors who are drivers of commercial motor vehicles rated at 26,001 lbs. or more and operate across state lines at any time or are engaged in safety-sensitive pipeline operations are required by the Federal Government's Department of Transportation ("DOT") to implement a program of drug, alcohol and substance abuse testing, education and training (49 CFR Parts 40, 199, 391, and 394). These regulations require OWNER to assure that its Contractors and their employees, if any, comply with the drug, alcohol, and substance abuse testing regulations. Any Contractor who drives a commercial vehicle as described above or performs services identified as safety-sensitive must comply with the appropriate regulations and provide evidence of compliance to OWNER, including submitting copies of Contractor's annual MIS Report to OWNER by February 15th of the following year. Failure to provide such evidence will disqualify the Contractor from performing work or services for OWNER. OWNER is authorized by regulations to audit the Contractor's drug, alcohol and substance abuse program records. The work and/or services covered by this RFP are subject to the requirements stated in DOT 49 CFR (Safety-sensitive Pipeline Operations). The Contractor is responsible for drug testing, education, and training of its covered employees as required under 49 CFR Parts 40 and 199.

In the event that OWNER incurs a fine as a result of the Contractor's non-compliance with DOT regulations in the course of business, the Contractor will bear the cost of and will fully indemnify OWNER for the fine and may be subject to termination of any contract awarded pursuant to this Invitation to Bid.

NOTE: All costs associated with Contractor Drug, Alcohol, and Substance Abuse testing shall be the sole responsibility of the Contractor.

INFORMATION AVAILABLE TO BIDDERS

INFORMATION PLACED IN THIS SECTION IS NOT A PART OF THE CONTRACT DOCUMENTS.

Bidders and prospective Bidders are hereby warned and put on notice that the information contained within the documents indicated below was for design purposes only. This information was not obtained for the purposes of informing Bidders and prospective Bidders as to Work conditions covered by the Agreement for construction of the Project and is not, in the opinion of the Engineer, sufficient or extensive enough to provide an accurate or reliable indication of conditions which might be encountered in the performance of the Agreement and construction of the Project.

Neither the OWNER nor the ENGINEER has made any investigation of the conditions in the area covered by the Work to be performed other than the investigations mentioned above and, in bidding on this Project, each Bidder acknowledges making whatever investigation of conditions the Bidder has deemed necessary for the purposes of bidding.

SUBSURFACE DATA

1. A geotechnical investigation report, titled "Addison Natural Gas Project (ANGP) Preliminary Geotechnical Investigation Report" dated June 13, 2013 was completed in the vicinity of the Work. This report is digitally available to the Contractor at the website link noted in the Supplemental Conditions Section of the Project Manual Table of Contents.
2. A geotechnical investigation report, titled "GTX-300503 VT Gas" dated May 30, 2013 was completed in the vicinity of the Work. This report is digitally available to the Contractor at the website link noted in the Supplemental Conditions Section of the Project Manual Table of Contents.
3. Logs of the test borings referred to above are included in the Contract Documents; but are not a part of the Contract Documents. The availability of these borings is not intended to relieve Bidders of their obligation to make a thorough investigation of conditions below the surface of the ground and neither additional payment nor an extension of time will be made to the Contractor because the borings referred to above do not accurately represent the true nature of the subsurface conditions.
4. Bidders and prospective Bidders are hereby warned and put on notice that the borings referred to above were made for design purposes only. They were not made for the purpose of informing Bidders and prospective Bidders as to subsurface conditions in the area of the work covered by this Contract and are not, in the opinion of the ENGINEER, sufficient or extensive enough to provide an accurate or reliable indication of subsurface conditions which might be encountered in the performance of this Contract.
5. Neither the OWNER nor the ENGINEER has made any investigation of subsurface conditions in the area covered by the work to be performed under this Contract other than the borings referred to above, and, in bidding on this Contract, each Bidder acknowledges that he has made whatever investigation of subsurface conditions he had deemed necessary for the purpose of bidding. Permission for making borings of subsurface conditions will be arranged for by the ENGINEER upon receipt of a written request therefor.

OTHER DATA

1. Google Earth KMZ file showing the general location of the proposed project.
2. Tables for Jack/Bore Locations, Horizontal Directional Drill (HDD) Locations, Stream Crossings and Utility Infrastructure Crossings.
3. Mainline Valve Location Table.
4. Project Manual – Vermont Gas Systems Addison Natural Gas Project – Horizontal Directional Drill Design-Build.

GENERAL CONDITIONS

ARTICLE 1 - DEFINITIONS

Wherever used in these General Conditions or in the other Contract Documents the following terms have the meanings indicated which are applicable to both the singular and plural thereof:

1.1 **Addenda** – Written or graphic instruments issued prior to the opening of Bids which clarify, correct or change the Bidding Requirements or the Contract Documents.

1.2 **Agreement** – The written contract between OWNER and CONTRACTOR covering the Work to be performed; other Contract Documents are attached to the Agreement and made a part thereof as provided therein.

1.3 **Application for Payment** – The form accepted by ENGINEER which is to be used by CONTRACTOR in requesting progress or final payments and which is to be accompanied by such supporting documentation as is required by the Contract Documents.

1.4 **Asbestos** – Any material that contains more than one percent asbestos and is friable or is releasing asbestos fibers into the air above current action levels established by the United States Occupational Safety and Health Administration.

1.5 **Bid** – The offer or proposal of the bidder submitted on the prescribed form setting forth the prices for the Work to be performed.

1.6 **Bidding Documents** – The advertisement or invitation to Bid, instructions to bidders, the Bid form, and the proposed Contract Documents (including all Addenda issued prior to receipt of Bids).

1.7 **Bidding Requirements** – The advertisement or invitation to Bid, instructions to bidders, and the Bid form.

1.8 **Bonds** – Performance and Payment bonds and other instruments of security.

1.9 **Change Order** – A document recommended by ENGINEER, which is signed by CONTRACTOR and OWNER and authorizes an addition, deletion or revision in the Work, or an adjustment in the Contract Price or the Contract Times, issued on or after the Effective Date of the Agreement.

1.10 **Contract Documents** – The Agreement, Addenda (which pertain to the Contract Documents), CONTRACTOR's Bid (including documentation accompanying the Bid and any post Bid documentation submitted prior to the Notice of Award) when attached as an exhibit to the Agreement, the Notice to Proceed, the Bonds, these General Conditions, the Supplementary Conditions, the Specifications and the Drawings as the same are more specifically identified in the Agreement, together with all Written Amendments, Change Orders, Work Change Directives, Field Orders and ENGINEER's written interpretations and clarifications issued pursuant to paragraphs 3.5, 3.6.1, and 3.6.3 on or after the Effective Date of the Agreement. Shop Drawing submittals approved pursuant to paragraphs 6.26 and 6.27 and the reports and drawings referred to in paragraphs 4.2.1.1 and 4.2.2.2 are not Contract Documents.

1.11 **Contract Price** – The money payable by OWNER to CONTRACTOR for completion of the Work in accordance with the Contract Documents as stated in the Agreement (subject to the provisions of paragraph 11.9.1 in the case of Unit Price Work).

1.12 **Contract Times** – The numbers of days or the dates stated in the Agreement: (i) to achieve Substantial Completion, and (ii) to complete the Work so that it is ready for final payment as evidenced by ENGINEER's written recommendation of final payment in accordance with paragraph 14.13.

1.13 **CONTRACTOR** – The person, firm or corporation with whom OWNER has entered into the Agreement.

1.14 **Defective** – An adjective which when modifying the word Work refers to Work that is unsatisfactory, faulty or deficient, in that it does not conform to the Contract Documents, or does not meet the requirements of any inspection, reference standard, test or approval referred to in the Contract Documents, or has been damaged prior to ENGINEER's recommendation of final payment (unless responsibility for the protection thereof has been assumed by OWNER at Substantial Completion in accordance with paragraph 14.8 or 14.10).

1.15 **Drawings** – The drawings which show the scope, extent, and character of the Work to be furnished and performed by CONTRACTOR and which have been prepared or approved by ENGINEER and are referred to in the Contract Documents. Shop drawings are not Drawings as so defined.

1.16 **Effective Date of the Agreement** – The date indicated in the Agreement on which it becomes effective, but if no such date is indicated it means the date on which the Agreement is signed and delivered by the last of the two parties to sign and deliver.

1.17 **ENGINEER** – The person, firm, or corporation named as such in the Agreement.

1.18 **ENGINEER's Consultant** – A person, firm, or corporation having a contract with ENGINEER to furnish services as ENGINEER's independent professional associate or consultant with respect to the Project and who is identified as such in the Supplementary Conditions.

1.19 **Field Order** – A written order issued by ENGINEER which orders minor changes in the Work in accordance with paragraph 9.5 but which does not involve a change in the Contract Price or the Contract Times.

1.20 **General Requirements** – Sections of Division 1 of the Specifications.

1.21 **Hazardous Waste** – The term Hazardous Waste shall have the meaning provided in Section 1004 of the Solid Waste Disposal Act (42 USC Section 6903) as amended from time to time.

1.22 **Laws and Regulations; Laws or Regulations** – Any and all applicable laws, rules, regulations, ordinances, codes and orders of any and all governmental bodies, agencies, authorities and courts having jurisdiction.

1.23 **Liens** – Liens, charges, security interests, or encumbrances upon real property or personal property.

1.24 **Milestone** – A principal event specified in the Contract Documents relating to an intermediate completion date or time prior to Substantial Completion of all the Work.

1.25 **Notice of Award** – The written notice by OWNER to the apparent successful bidder stating that upon compliance by the apparent successful bidder with the conditions precedent enumerated therein, within the time specified, OWNER will sign and deliver the Agreement.

1.26 **Notice to Proceed** – A written notice given by OWNER to CONTRACTOR (with a copy to ENGINEER) fixing the date on which the Contract Times will commence to run and on which CONTRACTOR shall start to perform CONTRACTOR's obligations under the Contract Documents.

1.27 **OWNER** – The public body or authority, corporation, association, firm, or person with whom CONTRACTOR has entered into the Agreement and for whom the Work is to be provided.

1.28 **Partial Utilization** – Use by OWNER of a substantially completed part of the Work for the purpose for which it is intended (or a related purpose) prior to Substantial Completion of all the Work.

1.29 **PCBs** – Polychlorinated biphenyls.

1.30 **Petroleum** – Petroleum, including crude oil or any fraction thereof which is liquid at standard conditions of temperature and pressure (60 degrees Fahrenheit and 14.7 pounds per square inch absolute), such as oil, petroleum, fuel oil, oil sludge, oil refuse, gasoline, kerosene, and oil mixed with other non-Hazardous Wastes and crude oils.

1.31 **Project** – The total construction of which the Work to be provided under the Contract Documents may be the whole, or a part as indicated elsewhere in the Contract Documents.

1.32 **Radioactive Material** – Source, special nuclear or byproduct material as defined by the Atomic Energy Act of 1954 (42 USC Section 2011 et seq.) as amended from time to time.

1.33 **Resident Project Representative** – The authorized representative of ENGINEER who may be assigned to the site or any part thereof.

1.34 **Samples** – Physical examples of materials, equipment, or workmanship that are representative of some portion of the Work and which establish the standards by which such portion of the Work will be judged.

1.35 **Shop Drawings** – All drawings, diagrams, illustrations, schedules, and other data or information which are specifically prepared or assembled by or for CONTRACTOR and submitted by CONTRACTOR to illustrate some portion of the Work.

1.36 **Specifications** – Those portions of the Contract Documents consisting of written technical descriptions of materials, equipment, construction systems, standards, and workmanship as applied to the Work and certain administrative details applicable thereto.

1.37 **Subcontractor** – An individual, firm, or corporation having a direct contract with CONTRACTOR or with any other Subcontractor for performance of a part of the Work at the site.

1.38 **Substantial Completion** – The Work (or a specified part thereof) has progressed to the point where, in the opinion of ENGINEER as evidenced by ENGINEER’s definitive certificate of Substantial Completion, it is sufficiently complete, in accordance with the Contract Documents, so that the Work (or specified part) can be utilized for the purposes for which it is intended; or if no such certificate is issued, when the Work is complete and ready for final payment as evidenced by ENGINEER’s written recommendation of final payment in accordance with paragraph 14.13. The terms “substantially complete” and “substantially completed” as applied to all or part of the Work refer to Substantial Completion thereof.

1.39 **Supplementary Conditions** – The part of the Contract Documents which amends or supplements these General Conditions.

1.40 **Supplier** – A manufacturer, fabricator, supplier, distributor, materialman, or vendor having direct contract with CONTRACTOR or with any Subcontractor to furnish materials or equipment to be incorporated in the Work by CONTRACTOR or any Subcontractor.

1.41 **Underground Facilities** – All pipelines, conduits, ducts, cables, wires, manholes, vaults, tanks, tunnels, or other such facilities or attachments, and any encasements containing such facilities which have been installed underground to furnish any of the following services or materials: electricity, gases, steam, liquid petroleum products, telephone, or other communications, cable television, sewage and drainage removal, traffic or other control systems or water.

1.42 **Unit Price Work** – Work to be paid for on the basis of unit prices.

1.43 **Work** – The entire completed construction or the various separately identifiable parts thereof required to be furnished under the Contract Documents. Work includes and is the result of performing or furnishing labor and furnishings and incorporating materials and equipment into the construction, and performing or furnishing services and furnishing documents, all as required by the Contract Documents.

1.44 **Work Change Directive** - A written directive to CONTRACTOR, issued on or after the Effective Date of the Agreement and signed by OWNER and recommended by ENGINEER, ordering an addition, deletion, or revision in the Work, or responding to differing or unforeseen physical conditions under which the Work is to be performed as provided in paragraph 4.2 or 4.3 or to emergencies under paragraph

6.23. A Work Change Directive will not change the Contract Price or the Contract Times, but is evidence that the parties expect that the change directed or documented by a Work Change Directive will be incorporated in a subsequently issued Change Order following negotiations by the parties as to its effect, if any, on the Contract Price or Contract Times as provided in paragraph 10.2.

1.45 **Written Amendment** – A written amendment of the Contract Documents, signed by OWNER and CONTRACTOR on or after the Effective Date of the Agreement and normally dealing with the nonengineering or nontechnical rather than strictly construction-related aspects of the Contract Documents.

ARTICLE 2 - PRELIMINARY MATTERS

Delivery of Bonds:

2.1 When CONTRACTOR delivers the executed Agreements to OWNER, CONTRACTOR shall also deliver to OWNER such Bonds as CONTRACTOR may be required to furnish in accordance with Article 5

Copies of Documents:

2.2 OWNER shall furnish to CONTRACTOR up to ten copies (unless otherwise specified in the Supplementary Conditions) of the Contract Documents as are reasonably necessary for the execution of the Work. Additional copies will be furnished, upon request, at the cost of reproduction

Commencement of Contract Times; Notice to Proceed:

2.3 The Contract Times will commence to run on the thirtieth day after the Effective Date of the Agreement, or, if a Notice to Proceed is given, on the day indicated in the Notice to Proceed. A Notice to Proceed may be given at any time within thirty days after the Effective Date of the Agreement. In no event will the Contract Time commence to run later than the sixtieth day after the day of Bid opening or the thirtieth day after the Effective Date of the Agreement, whichever date is earlier.

Starting the Work:

2.4 CONTRACTOR shall start to perform the Work on the date when the Contract Times commence to run, but no Work shall be done at the site prior to the date on which the Contract Times commence to run.

Before Starting Construction:

2.5 Before undertaking each part of the Work, CONTRACTOR shall carefully study and compare the Contract Documents and check and verify pertinent figures shown thereon and all applicable field measurements. CONTRACTOR shall promptly report in writing to ENGINEER any conflict, error, ambiguity or discrepancy which CONTRACTOR may discover and shall obtain a written interpretation or clarification from ENGINEER before proceeding with any Work affected thereby; however, CONTRACTOR shall not be liable to OWNER or ENGINEER for failure to report any conflict, error, ambiguity or discrepancy in the Contract Documents, unless CONTRACTOR knew or reasonably should have known thereof.

2.6 Within ten days after the Effective Date of the Agreement (unless otherwise specified in the General Requirements). CONTRACTOR shall submit to ENGINEER for review:

2.6.1 a preliminary progress schedule indicating the times (numbers of days or dates) for starting and completing the various stages of the Work, including any Milestones specified in the Contract Documents;

2.6.2 a preliminary schedule of Shop Drawings and Sample submittals which will list each required submittal and the times for submitting, reviewing and processing such submittal;

2.6.3 a preliminary schedule of values for all of the Work which will include quantities and prices of items aggregating the Contract Price and will subdivide the Work into component parts in sufficient detail to serve as the basis for progress payments during construction. Such prices will include and appropriate amount of overhead and profit applicable to each item of Work.

2.7 Before any Work at the site is started, CONTRACTOR and OWNER shall each deliver to the other, with copies to each additional insured identified in the Supplementary Conditions, certificates of insurance (and other evidence of insurance which either of them or any additional insured may reasonably request) which CONTRACTOR and OWNER respectively are required to purchase and maintain in accordance with Article 5.

Preconstruction Conference:

2.8 Within twenty days after the Contract Times start to run, but before any Work at the site is started, a conference attended by CONTRACTOR, ENGINEER and others as appropriate will be held to establish a working understanding among the parties as to the

Work and to discuss the schedules referred to in paragraph 2.6, procedures for handling Shop Drawings, and other submittals, processing Applications for Payment and maintaining required records.

Initially Acceptable Schedules:

2.9 Unless otherwise provided in the Contract Documents, at least ten days before submission of the first Application for Payment a conference attended by CONTRACTOR, ENGINEER, and others as appropriate will be held to review for acceptability to ENGINEER as provided below the schedules submitted in accordance with paragraph 2.6. CONTRACTOR shall have an additional ten days to make corrections and adjustments and to complete and resubmit the schedules. No progress payment shall be made to CONTRACTOR until the schedules are submitted to and acceptable to ENGINEER as provided below. The progress schedule will be acceptable to ENGINEER as providing an orderly progression of the Work to completion within any specified Milestones and the Contract Times, but such acceptance will neither impose on ENGINEER responsibility for the sequencing, scheduling, or progress of Work nor interfere with or relieve CONTRACTOR from CONTRACTOR's full responsibility therefore, CONTRACTOR's schedule of Shop Drawing and Sample submissions will be acceptable to ENGINEER as providing a workable arrangement for reviewing and processing the required submittals. CONTRACTOR's schedule of values will be acceptable to ENGINEER as to form and substance.

ARTICLE 3 - Contract Documents: INTENT, AMENDING, REUSE

Intent:

3.1 The Contract Documents comprise the entire agreement between OWNER and CONTRACTOR concerning the Work. The Contract Documents are complementary: what is called for by one is as binding as if called for by all. The Contract Documents will be construed in accordance with the law of the place of the Project.

3.2 It is the intent of the Contract Documents to describe a functionally complete Project (or part thereof) to be constructed in accordance with the Contract Documents. Any Work, materials, or equipment that may reasonably be inferred from the Contract Documents or from prevailing custom or trade usage as being required to produce the intended result will be furnished and performed whether or not

specifically called for. When words or phrases which have a well-known technical or construction industry or trade meaning are used to describe Work, materials, or equipment, such words or phrases shall be interpreted in accordance with the meaning. Clarifications and interpretations of the Contract Documents shall be issued by ENGINEER as provided in paragraph 9.4.

3.3 Reference to Standards and Specifications of Technical Societies: Reporting and Resolving Discrepancies:

3.3.1 Reference to standards, specifications, manuals or codes of any technical society, organization, or association, or to the Laws or Regulations of any governmental authority, whether such reference be specific or by implication, shall mean the latest standard, specification, manual, code or Laws or Regulations in effect at the time of opening of Bids (or, on the Effective Date of the Agreement if there were no Bids), except as may be otherwise specifically stated in the Contract Documents.

3.3.2 If, during the performance of the Work, CONTRACTOR discovers any conflict, error, ambiguity, or discrepancy within the Contract Documents or between the Contract Documents and any provision of any such Law or Regulation applicable to the performance of the Work or of any such standard, specification, manual, or code or of any instruction of any Supplier referred to in paragraph 6.5. CONTRACTOR shall report it to ENGINEER in writing at once, and, CONTRACTOR shall not proceed with the Work affected thereby (except in an emergency as authorized by paragraph 6.23) until an amendment or supplement to the Contract Documents has been issued by one of the methods indicated in paragraph 3.5 or 3.6; provide, however, that CONTRACTOR shall not be liable to OWNER or ENGINEER for failure to report any such conflict, error, ambiguity or discrepancy unless CONTRACTOR knew or reasonably should have known thereof.

3.3.3 Except as otherwise specifically stated in the Contract Documents or as may be provided by amendment or supplement thereto issued by one of the methods indicated in paragraph 3.5 or 3.6, the provisions of the Contract Documents shall take precedence in resolving any conflict, error, ambiguity, or discrepancy between the provisions of the Contract Documents and:

3.3.3.1 the provisions of any such standard, specification, manual, code, or instruction (whether or not specifically incorporated by reference in the Contract Documents): or

3.3.3.2 the provisions of any such Laws or Regulations applicable to the performance of the Work (unless such an interpretation of the provisions of the Contract Documents would result in violation of such Law or Regulation).

No provision of any such standard, specification, manual, code, or instruction shall be effective to change the duties and responsibilities of OWNER, CONTRACTOR, or ENGINEER, or any of their subcontractors, consultants, agents, or employees from those set forth in the Contract Documents, nor shall it be effective to assign to OWNER, ENGINEER, or any of ENGINEER's Consultants, agents, or employees any duty or authority to supervise or direct the furnishing or performance of the Work or any duty or authority to undertake responsibility inconsistent with the provisions of paragraph 9.13 or any other provision of the Contract Documents.

3.4 Whenever in the Contract Documents the terms "as ordered," "as directed," "as required," "as allowed," "as approved" or terms of like effect or import are used, or the adjectives "reasonable," "suitable," "acceptable," "proper," or "satisfactory" or adjectives of like effect or import are used to describe a requirement, direction, review or judgment of ENGINEER as to the Work, it is intended that such requirement, direction, review, or judgment will be solely to evaluate, in general, the completed Work for compliance with the requirements of and information in the Contract Documents and conformance with the design concept of the completed Project as a functioning whole as shown or indicated in the Contract Documents (unless there is a specific statement indicating otherwise). The use of any such term or adjective shall not be effective to assign to ENGINEER any duty or authority to supervise or direct the furnishing or performance of the Work or any duty or authority to undertake responsibility contrary to the provisions of paragraph 9.13 or any other provision of the Contract Documents.

Amending and Supplementing Contract Documents:

3.5 The Contract Documents may be amended to provide for additions, deletions, and revisions in the Work or to modify the terms and conditions thereof in one or more of the following ways:

3.5.1 a formal Written Amendment.

3.5.2 a Change Order (pursuant to paragraph 10.4) or

3.5.3 a Work Change Directive (pursuant to paragraph 10.1).

Supplementing Contract Documents:

3.6 In addition, the requirements of the Contract Documents may be supplemented, and minor variations, and deviations of the Work may be authorized, in one or more of the following ways:

3.6.1 a Field Order (pursuant to paragraph 9.5).

3.6.2 ENGINEER's approval of a Shop Drawing or Sample (pursuant to paragraphs 6.26 and 6.27), or

3.6.3 ENGINEER's written interpretation or clarification (pursuant to paragraph 9.4).

Reuse of Documents:

3.7 CONTRACTOR and any Subcontractor or Supplier or other person or organization performing or furnishing any of the Work under a direct or indirect contract with OWNER (i) shall not have or acquire any title to or ownership rights in any of the Drawings, Specifications, or other documents (or copies of any thereof) prepared by or bearing the seal of ENGINEER or ENGINEER's Consultant, and (ii) shall not reuse any of such Drawings, Specifications, other documents, or copies on extensions of the Project or any other project without written consent of OWNER and ENGINEER and specific written verification of adaptation by ENGINEER.

**ARTICLE 4 - AVAILABILITY OF LANDS:
SUBSURFACE AND PHYSICAL CONDITIONS;
REFERENCE POINTS**

Availability of Lands:

4.1 OWNER shall furnish, as indicated in the Contract Documents, the lands upon which the Work is to be performed, rights-of-way and easements for access thereto, and such other lands which are designated for the use of CONTRACTOR. Upon reasonable written request, OWNER shall furnish CONTRACTOR with a correct statement of record legal title and legal description of the lands upon which the Work is to be performed and OWNER's interest therein as necessary for giving notice of or filing a mechanic's lien against such lands in accordance with applicable Laws and Regulations. OWNER shall identify any encumbrances or restrictions not of general application but specifically related to use of lands so furnished with which CONTRACTOR will

have to comply in performing the Work. Easements for permanent structures or permanent in existing facilities will be obtained and paid for by OWNER, unless otherwise provided in the Contract Documents. If CONTRACTOR and OWNER are unable to agree on entitlement to or the amount or extent of any adjustments in the Contract Price or the Contract Times as a result of any delay in OWNER's furnishing these lands, rights-of-way or easements. CONTRACTOR may make a claim therefore as provided in Articles 11 and 12. CONTRACTOR shall provide for all additional lands and access thereto that may be required for temporary construction facilities or storage of materials and equipment.

4.2 Subsurface and Physical Conditions:

4.2.1 **Reports and Drawings:** Reference is made to the Supplementary Conditions for identification of:

4.2.1.1 **Subsurface Conditions:** Those reports of explorations and tests of Subsurface conditions at or contiguous to the site that have been utilized by ENGINEER in preparing the Contract Documents; and

4.2.1.2 **Physical Conditions:** Those drawings of physical conditions in or relating to existing surface or Subsurface structures at or contiguous to the site (except Underground Facilities) that have been utilized by ENGINEER in preparing the Contract Documents.

4.2.2 **Limited Reliance by CONTRACTOR Authorized; Technical Data:** CONTRACTOR may rely upon the general accuracy of the "technical data" contained in such reports and drawings, but such reports and drawings are not Contract Documents. Such "technical data" is identified in the Supplementary Conditions. Except for such reliance on such "technical data," CONTRACTOR may not rely upon or make any claim against OWNER, ENGINEER, or any of ENGINEER's Consultants with respect to:

4.2.2.1 the completeness of such reports and drawings for CONTRACTOR's purposes, including, but not limited to, any aspects of the means, methods, techniques, sequences and procedures of construction to be employed by CONTRACTOR and safety precautions and programs incident thereto, or

4.2.2.2 other data, interpretations, opinions, and information contained in such reports or shown or indicated in such drawings, or

4.2.2.3 any CONTRACTOR interpretation of or conclusion drawn from any "technical data" or any such data, interpretations, opinions, or information.

4.2.3 Notice of Differing Subsurface or Physical Conditions: If CONTRACTOR believes that any Subsurface or physical condition at or contiguous to the site that is uncovered or revealed either:

4.2.3.1 is of such a nature as to establish that any “technical data” on which CONTRACTOR is entitled to rely as provided in paragraphs 4.2.1 and 4.2.2 is materially inaccurate, or

4.2.3.2 is of such a nature as to require a change in the Contract Documents, or

4.2.3.3 differs materially from that shown or indicated in the Contract Documents, or

4.2.3.4 is of an unusual nature, and differs materially from conditions ordinarily encountered and generally recognized as inherent in work of the character provided for in the Contract Documents; then

CONTRACTOR shall, promptly after becoming aware thereof and before further disturbing conditions affected thereby or performing any Work in connection therewith (except in an emergency as permitted by paragraph 6.23), notify OWNER and ENGINEER in writing about such condition. CONTRACTOR shall not further disturb such conditions or perform any Work in connection therewith (except as aforesaid) until receipt of written order to do so.

4.2.4 ENGINEER’s Review: ENGINEER will promptly review the pertinent conditions, determine the necessity of OWNER’s obtaining additional exploration or tests with respect thereto and advise OWNER in writing (with a copy to CONTRACTOR) of ENGINEER’s findings and conclusions.

4.2.5 Possible Contract Documents Change: If ENGINEER concludes that a change in the Contract Documents is required as a result of a condition that meets one or more of the categories in paragraph 4.2.3., a Work Change Directive or a Change Order will be issued as provided in Article 10 to reflect and document the consequences of such change.

4.2.6 Possible Price and Times Adjustments: An equitable adjustment in the Contract Price or in the Contract Times, or both, will be allowed to the extent that the existence of such uncovered or revealed condition causes an increase or decrease in CONTRACTOR’s cost of, or time required for performance of the Work; subject, however, to the following:

4.2.6.1 such condition must meet any one or more of the categories described in paragraphs 4.2.3.1 through 4.2.3.4, inclusive;

4.2.6.2 a change in the Contract Documents pursuant to paragraph 4.2.5 will not be an automatic authorization of nor a condition precedent to entitlement to any such adjustment;

4.2.6.3 with respect to Work that is paid for on a Unit Price Basis, any adjustment in Contract price will be subject to the provisions of paragraphs 9.10 and 11.9; and

4.2.6.4 CONTRACTOR shall not be entitled to any adjustment in the Contract Price or Times if;

4.2.6.4.1 CONTRACTOR knew of the existence of such conditions at the time CONTRACTOR made a final commitment to OWNER in respect of Contract Price and Contract Times by the submission of a bid or becoming bound under a negotiated contract: or

4.2.6.4.2 the existence of such condition could reasonably have been discovered or revealed as a result of any examination, investigation, exploration, test, or study of the site and contiguous areas required by the Bidding Requirements or Contract Documents to be conducted by or for CONTRACTOR prior to CONTRACTOR’s making such final commitment; or

4.2.6.4.3 CONTRACTOR failed to give the written notice within the time and as required by paragraph 4.2.3.

If OWNER and CONTRACTOR are unable to agree on entitlement to or as to the amount or length of any such equitable adjustment in the Contract Price or Contract Times, a claim may be made therefore as provided in Articles 11 and 12. However, OWNER, ENGINEER, and ENGINEER’s Consultants shall not be liable to CONTRACTOR for any claims, costs, losses, or damages sustained by CONTRACTOR on or in connection with any other project or anticipated project.

4.3 Physical Conditions – Underground Facilities:

4.3.1 Shown or Indicated: The information and data shown or indicated in the Contract Documents with respect to existing Underground Facilities at or contiguous to the site is based on information and data furnished to OWNER or ENGINEER by the owners of such Underground Facilities or by others. Unless it is otherwise expressly provided in the Supplementary Conditions:

4.3.1.1 OWNER and ENGINEER shall not be responsible for the accuracy or completeness of any such information or data; and

4.3.1.2 The cost of all of the following will be included in the Contract Price and CONTRACTOR shall have full responsibility for: (i) reviewing and checking all such information and data, (ii) locating all Underground Facilities shown or indicated in the Contract Documents, (iii) coordination of the Work with the owners of such Underground Facilities during construction, and (iv) the safety and protection of all such Underground Facilities as provided in paragraph 6.20 and repairing any damage thereto resulting from the Work.

4.3.2 **Not Shown or Indicated:** If an Underground Facility is uncovered or revealed at or contiguous to the site which was not shown or indicated in the Contract Documents. CONTRACTOR shall, promptly after becoming aware thereof and before further disturbing conditions affected thereby or performing any Work in connection therewith (except in an emergency as required by paragraph 6.23), identify the owner of such Underground Facility and give written notice to that owner and to OWNER and ENGINEER. ENGINEER will promptly review the Underground Facility and determine the extent, if any, to which a change is required in the Contract Documents to reflect and document the consequences of the existence of the Underground Facility. If ENGINEER concludes that a change in the Contract Documents is required, a Work Change Directive or a Change Order will be issued as provided in Article 10 to reflect and document such consequences. During such time, CONTRACTOR shall be responsible for the safety and protection of such Underground Facility as provided in paragraph 6.20. CONTRACTOR shall be allowed and increase in the Contract Price or an extension of the Contract Times, or both, to the extent that they are attributable to the existence of any Underground Facility that was not shown or indicated in the Contract Documents and that CONTRACTOR did not know of and could not reasonably have been expected to be aware of or to have anticipated. If OWNER and CONTRACTOR are unable to agree on entitlement to or the amount or length of any such adjustment in Contract Price or Contract Times. CONTRACTOR may make a claim, therefore, as provided in Articles 11 and 12. However, OWNER, ENGINEER, and ENGINEER's Consultants shall not be liable to CONTRACTOR for any claims, costs, losses or damages incurred or sustained by CONTRACTOR on or in connection with any other project or anticipated project.

Reference Points:

4.4 OWNER shall provide engineering surveys to establish reference points for construction which in ENGINEER's judgment are necessary to enable CONTRACTOR to proceed with the Work. CONTRACTOR shall be responsible for laying out the Work, shall protect and preserve the established reference points and shall make no changes or relocations without the prior written approval of OWNER, CONTRACTOR shall report to ENGINEER whenever any reference point is lost or destroyed or requires relocation because of necessary changes in grades or locations, and shall be responsible for the accurate replacement or relocation of such reference points by professionally qualified personnel.

4.5 Asbestos, PCBs, Petroleum, Hazardous Waste or Radioactive Material

4.5.1 OWNER shall be responsible for any Asbestos, PCBs, Petroleum, Hazardous Waste, or Radioactive Material uncovered or revealed at the site which was not shown or indicated in Drawings or Specifications or identified in the Contract Documents to be within the scope of the Work and which may present a substantial danger to persons or property exposed thereto in connection with the Work at the site. OWNER shall not be responsible for any such materials brought to the site by CONTRACTOR, Subcontractor, Suppliers, or anyone else for whom CONTRACTOR is responsible.

4.5.2 CONTRACTOR shall immediately: (i) stop all Work in connection with such hazardous condition and in any area affected thereby (except in an emergency as required by paragraph 6.23), and (ii) notify OWNER and ENGINEER (and thereafter confirm such notice in writing). OWNER shall promptly consult with ENGINEER concerning the necessity for OWNER to retain a qualified expert to evaluate such hazardous condition to take corrective action, if any. CONTRACTOR shall not be required to resume Work in connection with such hazardous condition or in any such affected area until after OWNER has obtained any required permits related thereto and delivered to CONTRACTOR special written notice: (i) specifying that such condition and any affected area is or has been rendered safe for the resumption of Work, or (ii) specifying any special conditions under which such Work may be resumed safely. If OWNER and CONTRACTOR cannot agree as to entitlement to or the amount or extent of an adjustment, if any, in Contract Price or Contract Times as a result of such Work stoppage or such special conditions under which Work is agreed by CONTRACTOR to be resumed, either party may make a claim therefore as provided in Articles 11 and 12.

4.5.3 If after receipt of such special written notice CONTRACTOR does not agree to resume such Work based on a reasonable belief it is unsafe, or does not agree to resume such Work under such special conditions, then OWNER may order such portion of the Work that is in connection with such hazardous condition or in such affected area to be deleted from the Work. If OWNER and CONTRACTOR cannot agree as to entitlement to or the amount or extent of an adjustment, if any, in Contract Price or Contract Times as a result of deleting such portion of the Work, then either party may make a claim therefore as provided in Articles 11 and 12. OWNER may have such deleted portion of the Work performed by OWNER's own forces or others in accordance with Article 7.

4.5.4 To the fullest extent permitted by Laws and Regulations, OWNER shall indemnify and hold harmless CONTRACTOR, Subcontractors, ENGINEER, ENGINEER's Consultants and the officers, directors, employees, agents, other consultants and subcontractors of each and any of them from and against all claims, costs, losses, and damages arising out of or resulting from such hazardous condition, provided that: (i) any such claim, cost, loss, or damage is attributable to bodily injury, sickness, disease, or death, or to injury to or destruction of tangible property (other than the Work itself), including the loss of use resulting therefrom, and (ii) nothing in this subparagraph 4.5.4. shall obligate OWNER to indemnify any person or entity from and against the consequences of that person's or entity's own negligence.

4.5.5 The provisions of paragraphs 4.2 and 4.3 are not intended to apply to Asbestos, PCBs, Petroleum, Hazardous Waste or Radioactive Material uncovered or revealed at the site.

ARTICLE 5 - BONDS AND INSURANCE

Performance, Payment, and Other Bonds:

5.1 CONTRACTOR shall furnish Performance and Payment Bonds, each in an amount at least equal to the Contract Price as security for the faithful performance and payment of all CONTRACTOR's obligations under the Contract Documents. These Bonds shall remain in effect at least until one year after the date when final payment becomes due, except as provided otherwise by Laws or Regulations or by the Contract Documents. CONTRACTOR shall also furnish such other Bonds as are required by the Supplementary Conditions. All Bonds shall be in the form prescribed by the Contract Documents except as

provided otherwise by Laws or Regulations, an shall be executed by such sureties as are named in the current list of "Companies Holding Certificates of Authority as Acceptable Sureties on Federal Bonds and as Acceptable Reinsuring Companies" as published in Circular 570 (amended) by the Audit Staff. Bureau of Government Financial Operations, U.S. Treasury Department. All Bonds signed by an agent must be accompanied by a certified copy of such agent's authority to act.

5.2 If the surety on any Bond furnished by CONTRACTOR is declared a bankrupt or becomes insolvent or its right to do business is terminated in any state where any part of the Project is located or it ceases to meet the requirements of paragraph 5.1. CONTRACTOR shall within ten days thereafter substitute another bond and surety, both of which must be acceptable to OWNER.

5.3 Licensed Sureties and Insurers; Certificates of Insurance:

5.3.1 All Bonds and insurance required by the Contract Documents to be purchased and maintained by OWNER or CONTRACTOR shall be obtained from surety or insurance companies that are duly licensed or authorized in the jurisdiction in which the Project is located to issue Bonds or insurance policies for the limits and coverages so required. Such surety and insurance companies shall also meet such additional requirements and qualifications as may be provided in the Supplementary Conditions.

5.3.2 CONTRACTOR shall deliver to OWNER, with copies to each additional insured identified in the Supplementary Conditions, certificates of insurance (and other evidence of insurance requested by OWNER or any other additional insured) which CONTRACTOR is required to purchase and maintain in accordance with paragraph 5.4. OWNER shall deliver to CONTRACTOR, with copies to each additional insured identified in the Supplementary Conditions, certificates of insurance (and other evidence of insurance requested by CONTRACTOR or any other additional insured) which OWNER is required to purchase and maintain in accordance with paragraphs 5.6 and 5.7 hereof.

CONTRACTOR's Liability Insurance:

5.4 CONTRACTOR shall purchase and maintain such liability and other insurance as is appropriate for the Work being performed and furnished and as will provide protection from claims set forth below which may arise out of or result from CONTRACTOR's performance and furnishing of the Work and CONTRACTOR's other obligations under the Contract

Documents, whether it is to be performed or furnished by CONTRACTOR, any Subcontractor or Supplier, or by anyone directly or indirectly employed by any of them to perform or furnish any of the Work, or by anyone for whose acts any of them may be liable:

5.4.1 claims under workers' compensation, disability benefits and other similar employee benefit acts;

5.4.2 claims for damages because of bodily injury, occupational sickness or disease, or death of CONTRACTOR's employees;

5.4.3 claims for damages because of bodily injury, sickness or disease, or death of any person other than CONTRACTOR's employees;

5.4.4 claims for damages insured by customary personal injury liability coverage which are sustained: (i) by any person as a result of an offense directly or indirectly related to the employment of such person by CONTRACTOR, or by any other person for any other reason;

5.4.5 claims for damages, other than to the Work itself, because of injury to or destruction of tangible property wherever located, including loss of use resulting therefrom; and

5.4.6 claims for damages because of bodily injury or death of any person or property damage arising out of the ownership, maintenance or use of any motor vehicle.

The policies of insurance so required by this paragraph 5.4 to be purchased and maintained shall:

5.4.7 with respect to insurance required by paragraphs 5.4.3 through 5.4.6 inclusive, include as additional insureds (subject to any customary exclusion in respect of professional liability) OWNER, ENGINEER, ENGINEER's Consultants and any other persons or entities identified in the Supplementary Conditions, all of whom shall be listed as additional insureds, and include coverage for the respective officers and employees of all such additional insureds;

5.4.8 include the specific coverages and be written for not less than the limits of liability provided in the Supplementary Conditions or required by Laws or Regulations, whichever is greater;

5.4.9 include completed operations insurance;

5.4.10 include contractual liability insurance covering CONTRACTOR's indemnity obligations under

paragraphs 6.12, 6.16, and 6.31 through 6.33;

5.4.11 contain a provision or endorsement that the coverage afforded will not be canceled, materially changed or renewal refused until at least thirty days prior written notice has been given to OWNER and CONTRACTOR and to each other additional insured identified in the Supplementary Conditions to whom a certificate of insurance has been issued (and the certificates of insurance furnished by the CONTRACTOR pursuant to paragraph 5.3.2 will so provide);

5.4.12 remain in effect at least until final payment and at all times thereafter when CONTRACTOR may be correcting, removing or replacing defective Work in accordance with paragraph 13.12; and

5.4.13 with respect to completed operations insurance, and any insurance coverage written on a claims-made basis, remain in effect for at least two years after final payment (and CONTRACTOR shall furnish OWNER and each other additional insured identified in the Supplementary Conditions to whom a certificate of insurance has been issued evidence satisfactory to OWNER and any such additional insured of continuation of such insurance at final payment and one year thereafter).

OWNER's Liability Insurance:

5.5 In addition to the insurance required to be provided by CONTRACTOR under paragraph 5.4. OWNER, at OWNER's option, may purchase and maintain at OWNER's expense OWNER's own liability insurance as will protect OWNER against claims which may arise from operations under the Contract Documents.

Property Insurance:

5.6 Unless otherwise provided in the Supplementary Conditions, OWNER shall purchase and maintain property insurance upon the Work at the site in the amount of the full replacement cost thereof (subject to such deductible amounts as may be provided in the Supplementary Conditions or required by Laws and Regulations). This insurance shall:

5.6.1 include the interests of OWNER, CONTRACTOR, Subcontractors, ENGINEER, ENGINEER's Consultants and any other persons or entities identified in the Supplementary Conditions, each of whom is deemed to have an insurable interest and shall be listed as an insured or additional insured;

5.6.2 be written on a Builder's Risk "all-risk" or open peril or special causes of loss policy form that

shall at least include insurance for physical loss or damage to the Work, temporary buildings, falsework and Work in transit and shall insure against at least the following perils fire, lightning, extended coverage, theft, vandalism and malicious mischief, earthquake, collapse, debris removal, demolition occasioned by enforcement of Laws and Regulations, water damage, and such other perils as may be specifically required by the Supplementary Conditions;

5.6.3 include expenses incurred in the repair or replacement of any insured property (including but not limited to fees and charges of engineers and architects);

5.6.4 cover materials and equipment stored at the site or at another location that was agreed to in writing by OWNER prior to being incorporated in the Work, provided that such materials and equipment have been included in an Application for Payment recommended by ENGINEER; and

5.6.5 be maintained in effect until final payment is made unless otherwise agreed to in writing by OWNER, CONTRACTOR and ENGINEER with thirty days written notice to each other additional insured to whom a certificate of insurance has been issued.

5.7 OWNER shall purchase and maintain such boiler and machinery insurance or additional property insurance as may be required by the Supplementary Conditions or Laws and Regulations which will include the interests of OWNER, CONTRACTOR, Subcontractors, ENGINEER, ENGINEER's Consultants and any other persons or entities identified in the Supplementary Conditions, each of whom is deemed to have an insurable interest and shall be listed as an insured or additional insured.

5.8 All the policies of insurance (and the certificates or other evidence thereof) required to be purchased and maintained by OWNER in accordance with paragraphs 5.6 and 5.7 will contain a provision or endorsement that the coverage afforded will not be canceled or materially changed or renewal refused until at least thirty days prior written notice has been given to OWNER and CONTRACTOR and to each other additional insured to whom a certificate of insurance has been issued and will contain waiver provisions in accordance with paragraph 5.11.

5.9 OWNER shall not be responsible for purchasing and maintaining any property insurance to protect the interests of CONTRACTOR, Subcontractors or others in the Work to the extent of any deductible amounts that are identified in the Supplementary Conditions. The risk of loss within

such identified deductible amount, will be borne by CONTRACTOR, Subcontractor, or others suffering any such loss and if any of them wishes property insurance coverage within the limits of such amounts, each may purchase and maintain it at the purchaser's own expense.

5.10 If CONTRACTOR requests in writing that other special insurance be included in the property insurance policies provided under paragraphs 5.6 or 5.7, OWNER shall, if possible, include such insurance, and the cost thereof will be charged to CONTRACTOR by appropriate Change Order or Written Amendment. Prior to commencement of the Work at the site, OWNER shall in writing advise CONTRACTOR whether or not such other insurance has been procured by OWNER.

5.11 Waiver of Rights

5.11.1 OWNER and CONTRACTOR intend that all policies purchased in accordance with paragraphs 5.6 and 5.7 will protect OWNER, CONTRACTOR, Subcontractors, ENGINEER, ENGINEER's Consultants, and all other persons or entities identified in the Supplementary Conditions to be listed as insureds or additional insureds in such policies and will provide primary coverage for all losses and damages caused by the perils covered thereby. All such policies shall contain provisions to the effect that in the event of payment of any loss or damage the insurers will have no rights of recovery against any of the insureds or additional insureds thereunder. OWNER and CONTRACTOR waive all rights against each other and their respective officers, directors, employees, and agents for all losses and damages caused by, arising out of, or resulting from any of the perils covered by such policies and any other property insurance applicable to the Work; and, in addition, waive all such rights against Subcontractors, ENGINEER, ENGINEER's Consultants and all other persons or entities identified in the Supplementary Conditions to be listed as insureds or additional insureds under such policies for losses and damages so caused. None of the above waivers shall extend to the rights that any party making such waiver may have to the proceeds of insurance held by OWNER as trustee or otherwise payable under any policy so issued.

5.11.2 In addition, OWNER waives all rights against CONTRACTOR, Subcontractors, ENGINEER, ENGINEER's Consultants and the officers, directors, employees, and agents of any of them, for;

5.11.2.1 loss due to business interruption, loss of use or other consequential loss extending beyond direct physical loss or damage to OWNER's property or the Work caused by, arising out of or resulting from fire or

other peril, whether or not insureds by OWNER; and 5.11.2.2 loss or damage to the completed Project or part thereof caused by, arising out of or resulting from fire or other insureds peril coverage by any property insurance maintained on the completed Project or part thereof by OWNER during partial utilization pursuant to paragraph 14.10, after substantial completion pursuant to paragraph 14.8 or after final payment pursuant to paragraph 14.13.

Any insurance policy maintained by OWNER covering any loss, damage or consequential loss referred to in this paragraph 5.11.2 shall contain provisions to the effect that in the event of payment of any such loss, damage, or consequential loss the insurers will have not rights of recovery against any of CONTRACTOR, Subcontractors, ENGINEER, ENGINEER's Consultants and the officers, directors, employees, and agents of any of them.

Receipt and Application of Insurance Proceeds

5.12 Any insureds loss under the policies of insurance required by paragraphs 5.6 and 5.7 will be adjusted with OWNER and made payable to OWNER as fiduciary for the insureds, as their interests may appear, subject to the requirements of any applicable mortgage clause and of paragraph 5.13. OWNER shall deposit in a separate account any money so received, and shall distribute it in accordance with such agreement as the parties in interest may reach. If no other special agreement is reached the damaged Work shall be repaired or replaced, the moneys so received applied on account thereof and the Work and the cost thereof covered by an appropriate Change Order or Written Amendment.

5.13 OWNER as fiduciary shall have power to adjust and settle any loss with the insurers unless one of the parties in interest shall object in writing within fifteen days after the occurrence of loss to OWNER's exercise of this power. If such objection be made, OWNER as fiduciary shall make settlement with the insurers in accordance with such agreement as the parties in interest may reach. If no such agreement among the parties in interest is reached, OWNER as fiduciary shall adjust and settle the loss with the insurers and, if required in writing by any party in interest, OWNER as fiduciary shall give bond for the proper performance of such duties.

Acceptance of Bonds and Insurance; Option to Replace:

5.14 If either party (OWNER or CONTRACTOR) has any objection to the coverage afforded by or other provisions of the Bonds or insurance required to be purchased and maintained by the other party in

accordance with Article 5 on the basis of non-conformance with the Contract Documents, the objecting party shall so notify the other party in writing within ten days after receipt of the certificates (or other evidence requested) required by paragraph 2.7. OWNER and CONTRACTOR shall each provide to the other such additional information in respect of insurance provided as the other may reasonably request. If either party does not purchase or maintain all of the Bonds and insurance required of such party by the Contract Documents, such party shall notify the other party in writing of such failure to purchase prior to the start of the Work, or of such failure to maintain prior to any change in the required coverage. Without prejudice to any other right or remedy, the other party may elect to obtain equivalent Bonds or insurance to protect such other party's interests at the expense of the party who was required to provide such coverage, and a Change Order shall be issued to adjust the Contract Price accordingly.

Partial Utilization – Property Insurance:

5.15 If OWNER finds it necessary to occupy or use a portion or portions of the Work prior to Substantial Completion of all the Work, such use or occupancy may be accomplished in accordance with paragraph 14.10, provided that no such use or occupancy shall commence before the insurers providing the property insurance have acknowledged notice thereof and in writing effected any changes in coverage necessitated thereby. The insurers providing the property insurance shall consent by endorsement on the policy or policies, but the property insurance shall not be canceled or permitted to lapse on account of any such partial use or occupancy.

ARTICLE 6 - CONTRACTOR'S RESPONSIBILITIES

Supervision and Superintendence:

6.1 CONTRACTOR shall supervise, inspect and direct the Work competently and efficiently, devoting such attention thereto and applying such skills and expertise as may be necessary to perform the Work in accordance with the Contract Documents. CONTRACTOR shall be solely responsible for the means, methods, techniques, sequences and procedures of construction, but CONTRACTOR shall not be responsible for the negligence of others in the design or specification of a specific means, method, technique, sequence or procedure of construction which is shown or indicated in and expressly required by the Contract Documents. CONTRACTOR shall be responsible to see that the completed Work complies accurately with the Contract Documents.

6.2 CONTRACTOR shall keep on the Work at all times during its progress a competent resident superintendent, who shall not be replaced without written notice to OWNER and ENGINEER except under extraordinary circumstances. The superintendent will be CONTRACTOR's representative at the site and shall have authority to act on behalf of CONTRACTOR. All communications to the superintendent shall be as binding as if given to CONTRACTOR.

Labor, Materials and Equipment:

6.3 CONTRACTOR shall provide competent, suitably qualified personnel to survey, lay out and construct the Work as required by the Contract Documents. CONTRACTOR shall at all times maintain good discipline and order at the site. Except as otherwise required for the safety or protection of persons or the Work or property at the site or adjacent thereto, and except as otherwise indicated in the Contract Documents, all Work at the site shall be performed during regular working hours and CONTRACTOR will not permit overtime work or the performance of Work on Saturday, Sunday or any legal holiday without OWNER's written consent given after prior written notice to ENGINEER.

6.4 Unless otherwise specified in the General Requirements, CONTRACTOR shall furnish and assume full responsibility for all materials, equipment, labor, transportation, construction equipment and machinery, tools, appliances, fuel, power, light, heat, telephone, water, sanitary facilities, temporary facilities and all other facilities and incidentals necessary for the furnishing, performance, testing, start-up and completion of the Work.

6.5 All materials and equipment shall be of good quality and new, except as otherwise provided in the Contract Documents. All warranties and guarantees specifically called for by the Specifications shall expressly run to the benefit of OWNER. If required by ENGINEER, CONTRACTOR shall furnish satisfactory evidence (including reports of required tests) as to the kind and quality of materials and equipment. All materials and equipment shall be applied, installed, connected, erected, used, cleaned and conditioned in accordance with instructions of the applicable Supplier, except as otherwise provided in the Contract Documents.

Progress Schedule:

6.6 CONTRACTOR shall adhere to the progress schedule established in accordance with paragraph 2.9 as it may be adjusted from time to time as provided below:

6.6.1 CONTRACTOR shall submit to ENGINEER for acceptance (to the extent indicated in paragraph 2.9) proposed adjustments in the progress schedule that will not change the Contract Times (or Milestones). Such adjustments will conform generally to the progress schedule then in effect and additionally will comply with any provisions of the General Requirements applicable thereto.

6.6.2 Proposed adjustments in the progress schedule that will change the Contract Times (or Milestones) shall be submitted in accordance with the requirements of paragraph 12.1. Such adjustments may only be made by a Change Order or Written Amendment in accordance with Article 12.

6.7 Substitutes and "Or-Equal" Items:

6.7.1 Whenever an item of material or equipment is specified or described in the Contract Documents by using the name of a proprietary item or the name of a particular Supplier, the specification or description is intended to establish the type, function and quality required. Unless the specification or description contains or is followed by words reading that no like, equivalent or "or-equal" item or no substitution is permitted, other items of material or equipment or material or equipment of other Suppliers may be accepted by ENGINEER under the following circumstances:

6.7.1.1 "Or-Equal:" If in ENGINEER's sole discretion an item of material or equipment proposed by CONTRACTOR is functionally equal to that named and sufficiently similar so that no change in related Work will be required, it may be considered by ENGINEER as an "or-equal" item, in which case review and approval of the proposed item may, in ENGINEER's sole discretion, be accomplished without compliance with some or all of the requirements for acceptance of proposed substitute items.

6.7.1.2 **Substitute Items:** If in ENGINEER's sole discretion an item of material or equipment proposed by CONTRACTOR does not qualify as an "or-equal" item under subparagraph 6.7.1.1, it will be considered a proposed substitute item. CONTRACTOR shall submit sufficient information as provided below to allow ENGINEER to determine that the item of material or equipment proposed is essentially equivalent to that named and an acceptable substitute therefore. The procedure for review by the ENGINEER will include the following as supplemented in the General Requirements and as ENGINEER may decide is appropriate under the circumstances. Requests for review of proposed substitute items of material or equipment will not be

accepted by ENGINEER from anyone other than CONTRACTOR. If CONTRACTOR wishes to furnish or use a substitute item of material or equipment, CONTRACTOR shall first make written application to ENGINEER for acceptance thereof, certifying that the proposed substitute will perform adequately the functions and achieve the results called for by the general design, be similar in substance to that specified and be suited to the same use as that specified. The application will state the extent, if any, to which the evaluation and acceptance of the proposed substitute will prejudice CONTRACTOR's achievement of Substantial Completion on time, whether or not acceptance of the substitute for use in the Work will require a change in any of the Contract Documents (or in the provisions of any other direct contract with OWNER for work on the Project) to adapt the design to the proposed substitute and whether or not incorporation or use of the substitute in connection with the Work is subject to payment of any license fee or royalty. All variations of the proposed substitute from that specified will be identified in the application and available maintenance, repair and replacement service will be indicated. The application will also contain an itemized estimate of all costs or credits that will result directly or indirectly from acceptance of such substitute, including costs of redesign and claims of other contractors affected by the resulting change, all of which will be considered by ENGINEER in evaluating the proposed substitute. ENGINEER may require CONTRACTOR to furnish additional data about the proposed substitute.

6.7.1.3 CONTRACTOR's Expense: All data to be provided by CONTRACTOR in support of any proposed "or-equal" or substitute item will be at CONTRACTOR's expense.

6.7.2 Substitute Construction Methods or Procedures: If a specific means, method, technique, sequence or procedure of construction is shown or indicated in an expressly required by the Contract Documents, CONTRACTOR may furnish or utilize a substitute means, method, technique, sequence or procedure of construction acceptable to ENGINEER. CONTRACTOR shall submit sufficient information to allow ENGINEER, in ENGINEER's sole discretion, to determine that the substitute proposed is equivalent to that expressly called for by the Contract Documents. The procedure for review by ENGINEER will be similar to that provided in subparagraph 6.7.1.2.

6.7.3 ENGINEER's Evaluation: ENGINEER will be allowed a reasonable time within which to evaluate each proposal or submittal made pursuant to paragraphs 6.7.1.2 and 6.7.2. ENGINEER will be the sole judge of acceptability. No "or-equal" or substitute will be ordered, installed or utilized without

ENGINEER's prior written acceptance which will be evidenced by either a Change Order or an approved Shop Drawing. OWNER may require CONTRACTOR to furnish at CONTRACTOR's expense a special performance guarantee or other surety with respect to any "or-equal" or substitute. ENGINEER will record time required by ENGINEER and ENGINEER's Consultants in evaluating substitutes proposed or submitted by CONTRACTOR pursuant to paragraphs 6.7.1.2 and 6.7.2 and in making changes in the Contract Documents (or in the provisions of any other direct contract with OWNER for work on the Project) occasioned thereby. Whether or not ENGINEER accepts a substitute item so proposed or submitted by CONTRACTOR, CONTRACTOR shall reimburse OWNER for the changes of ENGINEER and ENGINEER's Consultants for evaluating each such proposed substitute item.

6.8 Concerning Subcontractors, Suppliers and Others:

6.8.1 CONTRACTOR shall not employ any Subcontractor, Supplier or other person or organization (including those acceptable to OWNER and ENGINEER as indicated in paragraph 6.8.2), whether initially or as a substitute, against whom OWNER or ENGINEER may have reasonable objection. CONTRACTOR shall not be required to employ any subcontractor, Supplier or other person or organization to furnish or perform any of the Work against whom CONTRACTOR has reasonable objection.

6.8.2 If the Supplementary Conditions require the identity of certain Subcontractors, Suppliers or other persons or organizations (including those who are to furnish the principal items of materials or equipment) to be submitted to OWNER in advance of the specified date prior to the Effective Date of the Agreement for acceptance by OWNER and ENGINEER, and if CONTRACTOR has submitted a list thereof in accordance with the Supplementary Conditions, OWNER's or ENGINEER's acceptance (either in writing or by failing to make written objection thereto by the date indicated for acceptance or objection in the bidding documents or the Contract Documents) of any such Subcontractor, Supplier or other person or organization so identified may be revoked on the basis of reasonable objection after due investigation, in which case CONTRACTOR shall submit an acceptable substitute, the Contract Price will be adjusted by the difference in the cost occasioned by such substitution and an appropriate Change Order will be issued or Written Amendment signed. No acceptance by OWNER or ENGINEER of any such Subcontractor, Supplier or other person or organization shall constitute a waiver of any right of OWNER or ENGINEER to reject **defective** Work.

6.9 CONTRACTOR shall be fully responsible to OWNER and ENGINEER for all acts and omissions of the Subcontractors, Suppliers and other persons and organizations performing or furnishing any of the Work under a direct or indirect contract with CONTRACTOR just as CONTRACTOR is responsible for CONTRACTOR's own acts and omissions. Nothing in the Contract Documents shall create for the benefit of any such Subcontractor, Supplier, or other person or organization any contractual relationship between OWNER or ENGINEER and any such Subcontractor, Supplier or other person or organization, nor shall it create any obligation on the part of OWNER or ENGINEER to pay or to see to the payment of any moneys due any such Subcontractor. Supplier or other person or organization except as may otherwise be required by Laws and Regulations.

6.9.1 CONTRACTOR shall be solely responsible for scheduling and coordinating the Work or Subcontractors, Suppliers and other persons and organizations performing or furnishing any of the Work under a direct or indirect contract with CONTRACTOR. CONTRACTOR shall require all Subcontractors, Suppliers and such other persons and organizations performing or furnishing any of the Work to communicate with the ENGINEER through CONTRACTOR.

6.10 The divisions and sections of the Specifications and the identifications of any drawings shall not control CONTRACTOR in dividing the Work among Subcontractors or Suppliers or delineating the Work to be performed by any specific trade.

6.11 All Work performed by CONTRACTOR by a Subcontractor or Supplier will be pursuant to an appropriate agreement between CONTRACTOR and the Subcontractor or Supplier which specifically binds the Subcontractor or Supplier to the applicable terms and conditions of the Contract Documents for the benefit of OWNER and ENGINEER. Whenever any such agreement is with a Subcontractor or Supplier who is listed as an additional insureds on the property insurance provided in paragraph 5.4.5. the agreement between the CONTRACTOR and the Subcontractor or Supplier will contain provisions whereby the Subcontractor or Supplier waives all rights against OWNER, CONTRACTOR, ENGINEER, ENGINEER's Consultants and all other additional insureds for all losses and damages caused by, arising out of or resulting from any of the perils covered by such policies and any other property insurance applicable to the Work. If the insurers on any such policies require separate waiver forms to be signed by

any Subcontractor or Supplier, CONTRACTOR will obtain the same.

Patent Fees and Royalties:

6.12 CONTRACTOR shall pay all license fees and royalties and assume all costs incident to the use in the performance of the Work or the incorporation in the Work of any invention, design, process, product or device which is the subject of patent rights or copyrights held by others. If a particular invention, design, process, product or device is specified in the Contract Documents for use in the performance of the Work and if to the actual knowledge of OWNER or ENGINEER its use is subject to patent rights or copyrights calling for the payment of any license fee or royalty to others, the existence of such rights shall be disclosed by OWNER in the Contract Documents. To the fullest extent permitted by Laws and Regulations, CONTRACTOR shall indemnify and hold harmless OWNER, ENGINEER, ENGINEER's Consultants and the officers, directors, employees, agents and other consultants of each and any of them from and against all claims, costs, losses and damages arising out of or resulting from any infringement of patent rights or copyrights incident to the use in the performance of the Work or resulting from the incorporation in the Work of any invention, design, process, product or device not specified in the Contract Documents.

Permits:

6.13 Unless otherwise provided in the Supplementary Conditions, CONTRACTOR shall obtain and pay for all construction permits and licenses. OWNER shall assist CONTRACTOR, when necessary, in obtaining such permits and licenses. CONTRACTOR shall pay all governmental charges and inspection fees necessary for the prosecution of the Work, which are applicable at the time of opening of Bids, or, if there are no Bids, on the Effective Date of the Agreement. CONTRACTOR shall pay all charges of utility owners for connections to the Work, and OWNER shall pay all charges of such utility owners for capital costs related thereto such as plant investment fees.

Laws and Regulations:

6.14 CONTRACTOR shall give all notices and comply with all Laws and Regulations applicable to furnishing and performance of the Work. Except where otherwise expressly required by applicable Laws and Regulations, neither OWNER nor ENGINEER shall be responsible for monitoring CONTRACTOR's compliance with any Laws or Regulations.

6.14.1 If CONTRACTOR performs any Work knowing or having reason to know that it is contrary to Laws or Regulations, CONTRACTOR shall bear all claims, costs, losses and damages caused by, arising out of or resulting therefrom: however, it shall not be CONTRACTOR's primary responsibility to make certain that the Specifications and Drawings are in accordance with Laws and Regulations, but this shall not relieve CONTRACTOR or CONTRACTOR's obligations under paragraph 3.3.2.

Taxes:

6.15 CONTRACTOR shall pay all sales, consumer, use and other similar taxes required to be paid by CONTRACTOR in accordance with the Laws and Regulations of the place of the Project which are applicable during the performance of the Work..

Use of Premises:

6.16 CONTRACTOR shall confine construction equipment, the storage of materials and equipment and the operations of workers to the site and land and areas identified in and permitted by the Contract Documents and other land and areas permitted Laws and Regulations, rights-of-way, permits and easements, and shall not unreasonably encumber the premises with construction equipment or other materials or equipment. CONTRACTOR shall assume full responsibility for any damage to any such land or area, or to the owner or occupant thereof or of any adjacent land or areas, resulting from the performance of the Work. Should any claim be made by any such owner or occupant because of the performance of the Work, CONTRACTOR shall promptly settle with such other party by negotiation or otherwise resolve the claim by arbitration or other dispute resolution proceeding or at law. CONTRACTOR shall to the fullest extent permitted by Laws and Regulations, indemnify and hold harmless OWNER, ENGINEER, ENGINEER's Consultant and anyone directly or indirectly employed by any of them from and against all claims costs, losses and damages arising out of or resulting from any claim or action, legal or equitable, brought by any such owner or occupant against OWNER, ENGINEER or any other party indemnified hereunder to the extent caused by or based upon CONTRACTOR's performance of the Work.

6.17 During the progress of the Work, CONTRACTOR shall keep the premises free from accumulations of waste materials, rubbish and other debris resulting from the Work. At the completion of the Work CONTRACTOR shall remove all waste materials, rubbish and debris from and about the premises as well as all tools, appliances, construction

equipment and machinery and surplus materials. CONTRACTOR shall leave the site clean and ready for occupancy by OWNER at Substantial Completion of the Work. CONTRACTOR shall restore to original condition all property not designated for alteration by the Contract Documents.

6.18 CONTRACTOR shall not load nor permit any part of any structure to be loaded in any manner that will endanger the structure, nor shall CONTRACTOR subject any part of the Work or adjacent property to stresses or pressures that will endanger it.

Record Documents:

6.19 CONTRACTOR shall maintain in a safe place at the site one record copy of all Drawings, Specifications, Addenda, Written Amendments, Change Orders, Work Change Directives, Field Orders and written interpretations and clarifications (issued pursuant to paragraph 9.4) in good order and annotated to show all changes made during construction. These record documents together with all approved Samples and a counterpart of all approved Shop Drawings will be available to ENGINEER for reference. Upon completion of the Work, these record documents, Samples and Shop Drawings will be delivered to ENGINEER for OWNER.

Safety and Protection:

6.20 CONTRACTOR shall be responsible for initiating, maintaining and supervising all safety precautions and programs in connection with the Work. CONTRACTOR shall take all necessary precautions for the safety of, and shall provide the necessary protection to prevent damage, injury or loss to:

6.20.1 all persons on the Work site or who may be affected by the Work;

6.20.2 all the Work and materials and equipment to be incorporated therein, whether in storage on or off the site; and

6.20.3 other property at the site or adjacent thereto, including trees, shrubs, lawns, walks, pavements, roadways, structures, utilities and Underground Facilities not designated for removal, relocation or replacement in the course of construction.

CONTRACTOR shall comply with all applicable Laws and Regulations of any public body having jurisdiction for safety of persons or property or to protect them from damage, injury of loss; and shall erect and maintain all necessary safeguards for such safety and protection. CONTRACTOR shall notify owners of adjacent property and of Underground

Facilities and utility owners when prosecution of the Work may affect them, and shall cooperate with them in the protection, removal, relocation and replacement of their property. All damage, injury or loss to any property referred to in paragraph 6.20.2. or 6.20.3. caused, directly or indirectly, in whole or in part, by CONTRACTOR, any Subcontractor, Supplier or any other person or organization directly or indirectly employed by any of them to perform or furnish any of the Work or anyone for whose acts any of them may be liable, shall be remedied by CONTRACTOR (except damage or loss attributable to the fault of Drawings or Specifications or to the acts or omissions of OWNER or ENGINEER or ENGINEER's Consultant or anyone employed by any of them or anyone for whose acts any of them may be liable, and not attributable, directly or indirectly, in whole or in part, to the fault or negligence of CONTRACTOR or any Subcontractor, Supplier or other person or organization directly or indirectly employed by any of them). CONTRACTOR's duties and responsibilities for safety and for protection of the Work shall continue until such time as all the Work is completed and ENGINEER has issued a notice to OWNER and CONTRACTOR in accordance with paragraph 14.13. that the Work is acceptable (except as otherwise expressly provided in connection with Substantial Completion).

Safety Representative:

6.21 CONTRACTOR shall designate a qualified and experienced safety representative at the site whose duties and responsibilities shall be the prevention of accidents and the maintaining and supervising of safety precautions and programs.

Hazard Communication Programs:

6.22 CONTRACTOR shall be responsible for coordinating any exchange of material safety data sheets or other hazard communication information required to be made available to or exchanged between or among employers at the site in accordance with Laws or Regulations.

Emergencies:

6.23 In emergencies affecting the safety or protection of persons or the Work or property at the site or adjacent thereto, CONTRACTOR, without special instruction or authorization from OWNER or ENGINEER, is obligated to act to prevent threatened damage, injury or loss. CONTRACTOR shall give ENGINEER prompt written notice if CONTRACTOR believes that any significant changes in the Work or variations from the Contract Documents have been caused thereby. If ENGINEER determines that a

change in the Contract Documents is required because of the action taken by CONTRACTOR in response to such an emergency, a Work Change Directive or Change Order will be issued to document the consequences of such action.

6.24 Shop Drawings and Samples:

6.24.1 CONTRACTOR shall submit Shop Drawings to ENGINEER for review and approval in accordance with the accepted schedule of Shop Drawings and Sample submittals (see paragraph 2.9.). All submittals will be identified as ENGINEER may require and in the number of copies specified in the General Requirements. The data shown on the Shop Drawings will be complete with respect to quantities, dimensions, specified performance and design criteria, materials and similar data to shown ENGINEER the materials and equipment CONTRACTOR proposes to provide and to enable ENGINEER to review the information for the limited purposes required by paragraph 6.26.

6.24.2 CONTRACTOR shall also submit Samples to ENGINEER for review and approval in accordance with said accepted schedule of Shop Drawings and Sample submittals. Each Sample will be identified clearly as to material, Supplier, pertinent data such as catalog numbers and the use for which intended and otherwise as ENGINEER may require to enable ENGINEER to review the submittal for the limited purposes required by paragraph 6.26. The numbers of each Sample to be submitted will be as specified in the Specifications.

6.25 Submittal Procedures:

6.25.1 Before submitting each Shop Drawing or Sample, CONTRACTOR shall have determined and verified:

6.25.1.1 all field measurements, quantities, dimensions, specified performance criteria, installation requirements, materials, catalog numbers and similar information with respect thereto,

6.25.1.2 all materials with respect to intended use, fabrication, shipping, handling storage, assembly and installation pertaining to the performance of the Work, and

6.25.1.3 all information relative to CONTRACTOR's sole responsibilities in respect of means, methods, techniques, sequences and procedures of construction and safety precautions and programs incident thereto.

CONTRACTOR shall also have reviewed and coordinated each Shop Drawing or Sample with

other Shop Drawings and Samples and with the requirements of the Work and the Contract Documents.

6.25.2 Each submittal will bear a stamp or specific written indication that CONTRACTOR has satisfied CONTRACTOR's obligations under the Contract Documents with respect to CONTRACTOR's review and approval of that submittal.

6.25.3 At the time of each submission, CONTRACTOR shall give ENGINEER specific written notice of such variations, if any, that the Shop Drawing or Sample submitted may have from the requirements of the Contract Documents, such notice to be in a written communication separate from the submittal; and, in addition, shall cause a specific notation to be made on each Shop Drawing and Sample submitted to ENGINEER for review and approval of each such variation.

6.26 ENGINEER will review and approve Shop Drawings and Samples in accordance with the schedule of Shop Drawings and Sample submittals accepted by ENGINEER as required by paragraph 2.9. ENGINEER's review and approval will be only to determine if the items covered by the submittals will, after installation or incorporation in the Work, conform to the information given in the Contract Documents and be compatible with the design concept of the completed Project as a functioning whole as indicated by the Contract Documents. ENGINEER's review and approval will not extend to means, methods, techniques, sequences or procedures of construction (except where a particular means, method, technique, sequence or procedure of construction is specifically and expressly called for by the Contract Documents) or to safety precautions or programs incident thereto. The review and approval of a separate item as such will not indicate approval of the assembly in which the item functions. CONTRACTOR shall make corrections required by ENGINEER, and shall return the required number of corrected copies of Shop Drawings and submit as required new Samples for review and approval. CONTRACTOR shall direct specific attention in writing to revisions other than the corrections called for by ENGINEER on previous submittals.

6.27 ENGINEER's review and approval of Shop Drawings or Samples shall not relieve CONTRACTOR from responsibility for any variation from the requirements of the Contract Documents unless CONTRACTOR has in writing called ENGINEER's attention to each such variation at the time of submission as required by paragraph 6.25.3 and ENGINEER has given written approval of each such variation by specific written notation thereof

incorporated in or accompanying Shop Drawing or Sample approval; nor will any approval by ENGINEER relieve CONTRACTOR from responsibility for complying with the requirements of paragraph 6.25.1.

6.28 Where a Shop Drawing or Sample is required by the Contract Documents or the schedule of Shop Drawings and Sample submissions accepted by ENGINEER as required by paragraph 2.9, any related Work performed prior to ENGINEER's review and approval of the pertinent submittal will be at the sole expense and responsibility of CONTRACTOR.

Continuing the Work:

6.29 CONTRACTOR shall carry on the Work and adhere to the progress schedule during all disputes or disagreements with OWNER. No Work shall be delayed or postponed pending resolution of any disputes or disagreements, except as permitted by paragraph 15.5 or as OWNER and CONTRACTOR may otherwise agree in writing.

6.30 CONTRACTOR's General Warranty and Guarantee:

6.30.1 CONTRACTOR warrants and guarantees to OWNER, ENGINEER and ENGINEER's Consultants that all Work will be in accordance with the Contract Documents and will not be defective. CONTRACTOR's warranty and guarantee hereunder excludes defects or damage caused by:

6.30.1.1 abuse, modification or improper maintenance or operation by persons other than CONTRACTOR, Subcontractors or Suppliers; or

6.30.1.2 normal wear and tear under normal usage.

6.30.2 CONTRACTOR's obligation to perform and complete the Work in accordance with the Contract Documents shall be absolute. None of the following will constitute an acceptance of Work that is not in accordance with the Contract Documents or a release of CONTRACTOR's obligation to perform the Work in accordance with the Contract Documents:

6.30.2.1 observations by ENGINEER;

6.30.2.2 recommendation of any progress or final payment by ENGINEER;

6.30.2.3 the issuance of a certificate of Substantial Completion or any payment by OWNER to CONTRACTOR under the Contract Documents;

6.30.2.4 use or occupancy of the Work or any part thereof by OWNER;

6.30.2.5 any acceptance by OWNER or any failure to do so;

6.30.2.6 any review and approval of Shop Drawing or Sample submittal or the issuance of a notice of acceptability by ENGINEER pursuant to paragraph 14.13;

6.30.2.7 any inspection, test or approval by others; or

6.30.2.8 any correction of defective Work by OWNER.

Indemnification:

6.31 To the fullest extent permitted by Laws and Regulations. CONTRACTOR shall indemnify and hold harmless OWNER, ENGINEER, ENGINEER's Consultants and the officers, directors, employees, agents and other consultants of each and any of them from and against all claims, costs, losses and damages (including but not limited to all fees and charges of engineers, architects, attorneys and other professionals and all court or arbitration or other dispute resolution costs) caused by, arising out of or resulting from the performance of the Work, provided that any such claim, cost, loss or damage: (i) is attributable to bodily injury, sickness, disease or death, or to injury to or destruction of tangible property (other than the Work itself), including the loss of use resulting therefrom, and (ii) is caused in whole or in part by any negligent act or omission of CONTRACTOR, any Subcontractor, any Supplier, any person or organization directly or indirectly employed by any of them to perform or furnish any of the Work or anyone for whose acts any of them may be liable, regardless of whether or not caused in part by any negligence or omission of a person or entity indemnified hereunder or whether liability is imposed upon such indemnified party by Laws and Regulations regardless of the negligence of any such person or entity.

6.32 In any and all claims against OWNER or ENGINEER or any of their respective consultants, agents, officers, directors or employees by any employee (or the survivor or personal representative of such employee) of CONTRACTOR, any Subcontractor, any Supplier, any person or organization directly or indirectly employed by any of them to perform or furnish any of the Work, or anyone for whose acts any of them may be liable, the indemnification obligation under paragraph 6.31 shall not be limited in any way by any limitation on the amount or type of damages, compensation or benefits

payable by or for CONTRACTOR or any such Subcontractor, Supplier or other person or organization under workers' compensation acts, disability benefit acts or other employee benefit acts.

6.33 The indemnification obligations of CONTRACTOR under paragraph 6.31 shall not extend to the liability of ENGINEER and ENGINEER's Consultants, officers, directors, employees or agents caused by the professional negligence, errors or omissions of any of them.

Survival of Obligations:

6.34 All representations, indemnifications, warranties and guarantees made in, required by or given in accordance with the Contract Documents, as well as all continuing obligations indicated in the Contract Documents, will survive final payment, completion and acceptance of the Work and termination or completion of the Agreement.

ARTICLE 7 - OTHER WORK

Related Work at Site:

7.1 OWNER may perform other work related to the Project at the site by OWNER's own forces, or let other direct contracts therefore which shall contain General Conditions similar to these, or have other work performed by utility owners. If the fact that such other work is to be performed was not noted in the Contract Documents, then; (i) written notice thereof will be given to CONTRACTOR prior to starting any such other work, and (ii) CONTRACTOR may make a claim therefore as provided in Articles 11 and 12 if CONTRACTOR believes that such performance will involve additional expense to CONTRACTOR or requires additional time and the parties are unable to agree as to the amount or extent thereof.

7.2 CONTRACTOR shall afford each other contractor who is a party to such a direct contract and each utility owner (and OWNER if OWNER is performing the additional work with OWNER's employees) proper and safe access to the site and a reasonable opportunity for the introduction and storage of materials and equipment and the execution of such other work and shall properly connect and coordinate the Work with theirs. Unless otherwise provided in the Contract Documents. CONTRACTOR shall do all cutting, fitting, and patching of the Work that may be required to make its several parts come together properly and integrate with such other work. CONTRACTOR shall not endanger any work of others by cutting, excavating or otherwise altering their work

and will only cut or alter their work with the written consent of ENGINEER and the others whose work will be affected. The duties and responsibilities of CONTRACTOR under this paragraph are for the benefit of such utility owners and other contractors to the extent that there are comparable provisions for the benefit of CONTRACTOR in said direct contracts between OWNER and such utility owners and other contractors.

7.3 If the proper execution or results of any part of CONTRACTOR's Work depends upon work performed by others under this Article 7. CONTRACTOR shall inspect such other work and promptly report to ENGINEER in writing any delays, defects or deficiencies in such other work that render it unavailable or unsuitable for the proper execution and results of CONTRACTOR's Work. CONTRACTOR's failure so to report will constitute an acceptance of such other work as fit and proper for integration with CONTRACTOR's Work except for latent or nonapparent defects and deficiencies in such other work.

Coordination:

7.4 If OWNER contracts with others for the performance of other work on the Project at the site, the following will be set forth in Supplementary Conditions:

7.4.1 the person, firm or corporation who will have authority and responsibility for coordination of the activities among the various prime contractors will be identified;

7.4.2 the specific matters to be covered by such authority and responsibility will be itemized; and

7.4.3 the extent of such authority and responsibilities will be provided.

Unless otherwise provided in the Supplementary Conditions, OWNER shall have sole authority and responsibility in respect of such coordination.

ARTICLE 8 - OWNER'S RESPONSIBILITIES

8.1 Except as otherwise provided in these General Conditions, OWNER shall issue all communications to CONTRACTOR through ENGINEER.

8.2 In case of termination of the employment of ENGINEER, OWNER shall appoint an engineer against whom CONTRACTOR makes no reasonable

objection, whose status under the Contract Documents shall be that of the former ENGINEER.

8.3 OWNER shall furnish the data required of OWNER under the Contract Documents promptly and shall make payments to CONTRACTOR promptly when they are due as provided in paragraphs 14.4 and 14.13.

8.4 OWNER's duties in respect of providing lands and easements and providing engineering surveys to establish reference points are set forth in paragraphs 4.1 and 4.4. Paragraph 4.2 refers to OWNER's identifying and making available to CONTRACTOR copies of reports of explorations and tests of Subsurface conditions at the site and drawings of physical conditions in existing structures at or contiguous to the site that have been utilized by ENGINEER in preparing the Contract Documents.

8.5 OWNER's responsibilities in respect of purchasing and maintaining liability and property insurance, if any, are set forth in the Supplementary Conditions.

8.6 OWNER is obligated to execute Change Orders as indicated in paragraph 10.4.

8.7 OWNER's responsibility in respect of certain inspections, tests and approvals is set forth in paragraph 13.4.

8.8 In connection with OWNER's right to stop Work or suspend Work, see paragraphs 13.10 and 15.1. Paragraph 15.2 deals with OWNER's right to terminate services of CONTRACTOR under certain circumstances.

8.9 The OWNER shall not supervise, direct or have control or authority over, nor be responsible for, CONTRACTOR's means, methods, techniques, sequences or procedures of construction or the safety precautions and programs incident thereto, or for any failure of CONTRACTOR to comply with Laws and Regulations applicable to the furnishing or performance of the Work. OWNER will not be responsible for CONTRACTOR's failure to perform or furnish the Work in accordance with the Contract Documents.

8.10 OWNER's responsibility in respect of undisclosed Asbestos, PCBs, Petroleum, Hazardous Waste or Radioactive Materials uncovered or revealed at the site is set forth in paragraph 4.5.

8.11 If and to the extent OWNER has agreed to furnish CONTRACTOR reasonable evidence that financial arrangements have been made to satisfy

OWNER's obligations under the Contract Documents, OWNER's responsibility in respect thereof will be as set forth in the Supplementary Conditions.

ARTICLE 9 - ENGINEER'S STATUS DURING CONSTRUCTION

OWNER's Representative:

9.1 ENGINEER will be OWNER's representative during the construction period. The duties and responsibilities and the limitations of authority of ENGINEER as OWNER's representative during construction are set forth in the Contract Documents and shall not be extended without written consent of OWNER and ENGINEER.

Visits to Site:

9.2 ENGINEER will make visits to the site at intervals appropriate to the various stages of construction as ENGINEER deems necessary in order to observe as an experienced and qualified design professional the progress that has been made and the quality of the various aspects of CONTRACTOR's executed Work. Based on information obtained during such visits and observations, ENGINEER will endeavor for the benefit of OWNER to determine, in general, if the Work is proceeding in accordance with the Contract Documents. ENGINEER will not be required to make exhaustive or continuous on-site inspections to check the quality or quantity of the Work. ENGINEER's efforts will be directed toward providing for OWNER a greater degree of confidence that the completed Work will conform generally to the Contract Documents. On the basis of such visits and on-site observations, ENGINEER will keep OWNER informed of the progress of the Work and will endeavor to guard OWNER against defective Work. ENGINEER's visits and on-site observations are subject to all the limitations on ENGINEER's authority and responsibility set forth in paragraph 9.13, and particularly, but without limitation, during or as a result of ENGINEER's on-site visits or observations of CONTRACTOR's Work ENGINEER will not supervise, direct, control or have authority over or be responsible for CONTRACTOR's means, methods, techniques, sequences or procedures of construction, or the safety precautions and programs incident thereto, or for any failure of CONTRACTOR to comply with Laws and Regulations applicable to the furnishing or performance of the Work.

Project Representative:

9.3 If OWNER and ENGINEER agree, ENGINEER will furnish a Resident Project Representative to assist ENGINEER in providing more continuous observation of the Work. The responsibilities and authority and limitations thereon of any such Resident Project Representative and assistants will be as provided in paragraph 9.13 and in the Supplementary Conditions. If OWNER designates another representative or agent to represent OWNER at the site who is not ENGINEER's Consultant, agent or employee, the responsibilities and authority and limitations thereon of such other person will be as provided in the Supplementary Conditions.

Clarifications and Interpretations:

9.4 ENGINEER will issue with reasonable promptness such written clarifications or interpretations of the requirements of the Contract Documents (in the form of Drawings or otherwise) as ENGINEER may determine necessary, which shall be consistent with the intent of and reasonably inferable from Contract Documents. Such written clarifications and interpretations will be binding on OWNER and CONTRACTOR. If OWNER or CONTRACTOR believes that a written clarification or interpretation justifies an adjustment in the Contract Price or the Contract Times and the parties are unable to agree to the amount or extent thereof, if any, OWNER or CONTRACTOR may make a written claim therefore as provided in Article 11 or Article 12.

Authorized Variations in Work:

9.5 ENGINEER may authorize minor variations in the Work from the requirements of the Contract Documents which do not involve an adjustment in the Contract Price or the Contract Times and are compatible with the design concept of the completed Project as a functioning whole as indicated by the Contract Documents. These may be accomplished by a Field Order and will be binding on OWNER and also on CONTRACTOR who shall perform the Work involved promptly. If OWNER or CONTRACTOR believes that a Field Order justifies an adjustment in the Contract Price or the Contract Times and the parties are unable to agree as to the amount or extent thereof, OWNER or CONTRACTOR may make a written claim therefore as provided in Article 11 or 12.

Rejecting Defective Work:

9.6 ENGINEER will have authority to disapprove or reject Work which ENGINEER believes to be defective, or that ENGINEER believes will not

produce a complete Project that conforms to the Contract Documents or that will prejudice the integrity of the design concept of the completed Project as a functioning whole as indicated by the Contract Documents. ENGINEER will also have authority to require special inspection or testing of the Work as provided in paragraph 13.9, whether or not the Work is fabricated, installed or completed.

Shop Drawings, Change Orders and Payments:

9.7 In connection with ENGINEER's authority as to Shop Drawings and Samples, see paragraphs 6.24 through 6.28 inclusive.

9.8 In connection with ENGINEER's authority as to Change Orders, see Articles 10,11, and 12.

9.9 In connection with ENGINEER's authority as to Applications for Payment, see Article 14.

Determinations for Unit Prices:

9.10 ENGINEER will determine the actual quantities and classifications of Unit Price Work performed by CONTRACTOR. ENGINEER will review with CONTRACTOR the ENGINEER's preliminary determinations on such matters before rendering a written decision thereon (by recommendation of an Application for Payment or otherwise). ENGINEER's written decision thereon will be final and binding upon OWNER and CONTRACTOR, unless, within ten days after the date of any such decision, either OWNER or CONTRACTOR delivers to the other and to ENGINEER written notice of intention to appeal from ENGINEER's decision and: (i) an appeal from ENGINEER's decision is taken within the time limits and in accordance with the procedures set forth in Exhibit GC-A, "Dispute Resolution Agreement," entered into between OWNER and CONTRACTOR pursuant to Article 16, or (ii) if no such Dispute Resolution Agreement has been entered into, a formal proceeding is instituted by the appealing party in a forum of competent jurisdiction to exercise such rights or remedies as the appealing party may have with respect to ENGINEER's decision, unless otherwise agreed in writing by OWNER and CONTRACTOR. Such appeal will not be subject to procedures of paragraph 9.11.

Decisions on Disputes:

9.11 ENGINEER will be the initial interpreter of the requirements of the Contract Documents and judge of the acceptability of the Work thereunder. Claims, disputes and other matters relating to the acceptability of the Work or the interpretation of the requirements of

the Contract Documents pertaining to the performance and furnishing of the Work and Claims under Articles 11 and 12 in respect of changes in the Contract Price or Contract Times will be referred initially to ENGINEER in writing with a request for a formal decision in accordance with this paragraph. Written notice of each such claim, dispute or other matter will be delivered by the claimant to ENGINEER and the other party to the Agreement promptly (but in no event later than thirty days) after the start of the occurrence or event giving rise thereto, and written supporting data will be submitted to ENGINEER and the other party within sixty days after the start of such occurrence or event unless ENGINEER allows an additional period of time for the submission of additional or more accurate data in support of such claim, dispute or other matter. The opposing party shall submit any response to ENGINEER and the claimant within thirty days after receipt of the claimant's last submittal (unless ENGINEER allows additional time). ENGINEER will render a formal decision in writing within thirty days after receipt of the opposing party's submittal, if any, in accordance with this paragraph. ENGINEER's written decision on such claim, dispute or other matter will be final and binding upon OWNER and CONTRACTOR unless: (i) an appeal from ENGINEER's decision is taken within the time limits and in accordance with the procedures set forth in EXHIBIT GC-A, "Dispute Resolution Agreement," entered into between OWNER and CONTRACTOR pursuant to Article 16, or (ii) if no such Dispute Resolution Agreement has been entered into, a written notice of intention to appeal from ENGINEER's written decision is delivered by OWNER or CONTRACTOR to the other and to ENGINEER within thirty days after the date of such decision and a formal proceeding is instituted by the appealing party in a forum of competent jurisdiction to exercise such rights or remedies as the appealing party may have with respect to such claim, dispute or other matter in accordance with applicable Laws and Regulations within sixty days of the date of such decision, unless otherwise agreed in writing by OWNER and CONTRACTOR.

9.12 When functioning as interpreter and judge under paragraphs 9.10 and 9.11, ENGINEER will not show partiality to OWNER or CONTRACTOR and will not be liable in connection with any interpretation or decision rendered in good faith in such capacity. The rendering of a decision by ENGINEER pursuant to paragraphs 9.10 or 9.11 with respect to any such claim, dispute or other matter (except any which have been waived by the making or acceptance of final payment as provided in paragraph 14.15) will be a condition precedent to any exercise by OWNER or CONTRACTOR of such rights or remedies as either

may otherwise have under the Contract Documents or by Laws or Regulations in respect of any such claim, dispute or other matter pursuant to Article 16.

9.13 Limitations on ENGINEER's Authority and Responsibilities:

9.13.1 Neither ENGINEER's authority or responsibility under this Article 9 or under any other provision of the Contract Documents nor any decision made by ENGINEER in good faith either to exercise or not exercise such authority or responsibility or the undertaking, exercise or performance of any authority or responsibility by ENGINEER shall create, impose or give rise to any duty owed by ENGINEER to CONTRACTOR, any Subcontractor, and Supplier, any other person or organization, or to any surety for or employee or agent of any of them.

9.13.2 ENGINEER will not supervise, direct, control or have authority over or be responsible for CONTRACTOR's means, methods, techniques, sequences or procedures of construction, or the safety precautions and programs incident thereto, or for any failure of CONTRACTOR to comply with Laws and Regulations applicable to the furnishing or performance of the Work. ENGINEER will not be responsible for CONTRACTOR's failure to perform or furnish the Work in accordance with the Contract Documents.

9.13.3 ENGINEER will not be responsible for the acts or omissions of CONTRACTOR or of any Subcontractor, any Supplier, or of any other person or organization performing or furnishing any of the Work.

9.13.4 ENGINEER's review of the final Application for Payment and accompanying documentation and all maintenance and operating instructions, schedules, guarantees, bonds and certificates of inspection, tests, and approvals and other documentation required to be delivered by paragraph 4.12 will only be to determine generally that their content complies with the requirements of, and in the case of certificates of inspections, tests and approvals that the results certified indicate compliance with, the Contract Documents.

9.13.5 The limitations upon authority and responsibility set forth in this paragraph 9.13 shall also apply to ENGINEER's Consultants, Resident Project Representative and assistants.

ARTICLE 10 - CHANGES IN THE WORK

10.1 Without invalidating the Agreement and without notice to any surety, OWNER may, at any time

or from time to time, order additions, deletions or revisions in the Work. Such additions, deletions or revisions will be authorized by a Written Amendment, a Change Order, or a Work Change Directive. Upon receipt of any such document, CONTRACTOR shall promptly proceed with the Work involved which will be performed under the applicable conditions of the Contract Documents (except as otherwise specifically provided).

10.2 If OWNER and CONTRACTOR are unable to agree as to the extent, if any, of an adjustment in the Contract Price or an adjustment of the Contract Times that should be allowed as a result of a Work Change Directive, a claim may be made therefore as provided in Article 11 or Article 12.

10.3 CONTRACTOR shall not be entitled to an increase in the Contract Price or an extension of the Contract Times with respect to any Work performed that is not required by the Contract Documents as amended, modified and supplemented as provided in paragraphs 3.5 and 3.6 except in the case of an emergency as provided in paragraph 6.23 or in the case of uncovering Work as provided in paragraph 13.9.

10.4 OWNER and CONTRACTOR shall execute appropriate Change Orders recommended by ENGINEER (or Written Amendments) covering:

10.4.1 changes in the Work which are (i) ordered by OWNER pursuant to paragraph 10.1, (ii) required because of acceptance of defective Work under paragraph 13.13 or correcting defective Work under paragraph 13.14, or (iii) agreed to by the parties;

10.4.2 changes in the Contract Price or Contract Times which are agreed to by the parties; and

10.4.3 changes in the Contract Price or Contract Times which embody the substance of any written decision rendered by ENGINEER pursuant to paragraph 9.11;

Provided that, in lieu of executing any such Change Order, an appeal may be taken from any such decision in accordance with the provisions of the Contract Documents and applicable Laws and Regulations, but during any such appeal, CONTRACTOR shall carry on the Work and adhere to the progress schedule as provided in paragraph 6.29.

10.5 If notice of any change affecting the general scope of the Work or the provisions of the Contract Documents (including, but not limited to, Contract Price or Contract Times) is required by the provisions of any Bond to be given to a surety, the giving of any

such notice will be CONTRACTOR's responsibility, and the amount of each applicable Bond will be adjusted accordingly.

ARTICLE 11 - CHANGE OF CONTRACT PRICE

11.1 The Contract Price constitutes the total compensation (subject to authorized adjustments) payable to CONTRACTOR for performing the Work. All duties, responsibilities and obligations assigned to or undertaken by CONTRACTOR shall be at CONTRACTOR's expense without change in the Contract Price.

11.2 The Contract Price may only be changed by a Change Order or by a Written Amendment. Any claim for an adjustment in the Contract Price shall be based on written notice delivered by the party making the claim to the other party and to ENGINEER promptly (but in no event later than thirty days) after the start of the occurrence or event giving rise to the claim and stating the general nature of the claim. Notice of the amount of the claim with supporting data shall be delivered within sixty days after the start of such occurrence or event (unless ENGINEER allows additional time for claimant to submit additional or more accurate data in support of the claim) and shall be accompanied by claimant's written statement that the adjustment claimed covers all known amounts to which the claimant is entitled as a result of said occurrence or event. All claims for adjustment in the Contract Price shall be determined by ENGINEER in accordance with paragraph 9.11 if OWNER and CONTRACTOR cannot otherwise agree on the amount involved. No claim for an adjustment in the Contract Price will be valid if not submitted in accordance with this paragraph 11.2.

11.3 The value of any Work covered by a Change Order or of any claim for an adjustment in the Contract Price will be determined as follows:

11.3.1 where the Work involved is covered by unit prices contained in the Contract Documents, by application of such unit prices to the quantities of the items involved (subject to the provisions of paragraphs 11.9.1. through 11.9.3. inclusive);

11.3.2 where the Work involved is not covered by unit prices contained in the Contract Documents, by a mutually agreed lump sum (which may include an allowance for overhead and profit not necessarily in accordance with paragraph 11.6.2):

11.3.3 where the Work involved is not covered by unit prices contained in the Contract Documents and

agreement to a lump sum is not reached under paragraph 11.3.2, on the basis of the Cost of the Work (determined as provided in paragraphs 11.4 and 11.5) plus a CONTRACTOR's fee for overhead and profit (determined as provided in paragraph 11.6).

Cost of the Work:

11.4 The term Cost of the Work means the sum of all costs necessarily incurred and paid by CONTRACTOR in the proper performance of the Work. Except as otherwise may be agreed to in writing by OWNER, such costs shall be in amounts no higher than those prevailing in the locality of the Project, shall include only the following items and shall not include any of the costs itemized in paragraph 11.5.

11.4.1 Payroll costs for employees in the direct employ of CONTRACTOR in the performance of the Work under schedules of job classifications agreed upon by OWNER and CONTRACTOR. Such employees shall include without limitation superintendents, foremen and other personnel employed full-time at the site. Payroll costs for employees not employed full-time on the Work shall be apportioned on the basis of their time spent on the Work. Payroll costs shall include, but not be limited to salaries and wages plus the cost of fringe benefits which shall include social security contributions, unemployment, excise and payroll taxes, worker's compensation, health and retirement benefits, bonuses, sick leave, vacation and holiday pay applicable thereto. The expenses of performing Work after regular working hours, on Saturday, Sunday or legal holidays, shall be included in the above to the extent authorized by OWNER.

11.4.2 Cost of all materials and equipment furnished and incorporated in the Work, including costs of transportation and storage thereof, and Suppliers' field services required in connection therewith. All cash discounts shall accrue to CONTRACTOR unless OWNER deposits funds with CONTRACTOR with which to make payments, in which case the cash discounts shall accrue to OWNER. All trade discounts, rebates and refunds and returns from sale of surplus materials and equipment shall accrue to OWNER, and CONTRACTOR shall make provisions so that they may be obtained.

11.4.3 Payments made by CONTRACTOR to the Subcontractors for Work performed or furnished by Subcontractors. If required by OWNER, CONTRACTOR shall obtain competitive bids from subcontractors acceptable to OWNER and CONTRACTOR and shall deliver such bids to

OWNER who will then determine, with the advice of ENGINEER, which bids, if any, will be accepted. If any subcontract provides that the Subcontractor is to be paid on the basis of Cost of the Work Plus a fee, the Subcontractor's Cost of the Work and fee shall be determined in the same manner as CONTRACTOR's Cost of the Work and fee as provided in paragraphs 11.4, 11.5, 11.6 and 11.7. All subcontracts shall be subject to the other provisions of the Contract Documents insofar as applicable.

11.4.4 Costs of special consultants (including but not limited to engineers, architects, testing laboratories, surveyors, attorneys and accountants) employed for services specifically related to the Work.

11.4.5 Supplemental costs including the following:

11.4.5.1 The proportion of necessary transportation, travel and subsistence expenses of CONTRACTOR's employees incurred in discharge of duties connected with the Work.

11.4.5.2 Cost, including transportation and maintenance, of all materials, supplies, equipment, machinery, appliances, office and temporary facilities at the site and hand tools not owned by the workers, which are consumed in the performance of the Work, and cost less market value of such items used but not consumed which remain the property of CONTRACTOR.

11.4.5.3 Rentals of all construction equipment and machinery and the parts thereof whether rented from CONTRACTOR or others in accordance with rental agreements approved by OWNER with the advice of ENGINEER, and the costs of transportation, loading, unloading, installation, dismantling and removal thereof – all in accordance with the terms of said rental agreements. The rental of any such equipment, machinery or parts shall cease when the use thereof is no longer necessary for the Work.

11.4.5.4 Sales, consumer, use or similar taxes related to the work, and for which CONTRACTOR is liable, imposed by Laws and Regulations.

11.4.5.5 Deposits lost for causes other than negligence of CONTRACTOR, any Subcontractor or anyone directly or indirectly employed by any of them or for whose acts any of them may be liable, and royalty payments and fees for permits and licenses.

11.4.5.6 Losses and damages (and related expenses) caused by damage to the Work, not compensated by insurance or otherwise, sustained by CONTRACTOR in connection with the performance and furnishing of the Work (except losses and damages within the deductible amounts of property insurance established

by OWNER), provided they have resulted from causes other than the negligence of CONTRACTOR, any Subcontractor, or anyone directly or indirectly employed by any of them or for whose acts any of them may be liable. Such losses shall include settlements made with the written consent and approval of OWNER. No such losses, damages and expenses shall be included in the Cost of the Work for the purpose of determining CONTRACTOR's fee. If, however, any such loss or damage requires reconstruction and CONTRACTOR is placed in charge thereof, CONTRACTOR is placed in charge thereof, CONTRACTOR shall be paid for services a fee proportionate to that stated in paragraph 11.6.2.

11.4.5.7 The cost of utilities, fuel and sanitary facilities at the site.

11.4.5.8 Minor expenses such as telegrams, long distance telephone calls, telephone service at the site, expressage and similar petty cash items in connection with the Work.

11.4.5.9 Cost of premiums for additional Bonds and insurance required because of changes in the Work.

11.5 The term Cost of the Work shall not include any of the following:

11.5.1 Payroll costs and other compensation of CONTRACTOR's officers, executives, principals (of partnership and sole proprietorships), general managers, engineers, architects, estimators, attorneys, auditors, accountants, purchasing and contracting agents, expeditors, timekeepers, clerks and other personnel employed by CONTRACTOR whether at the site or in CONTRACTOR's principal or a branch office for general administration of the Work and not specifically included in the agreed upon schedule of job classifications referred to in paragraph 11.4.1 or specifically covered by paragraph 11.4.4 – all of which are to be considered administrative costs covered by the CONTRACTOR's fee.

11.5.2 Expenses of CONTRACTOR's principal and branch offices other than CONTRACTOR's office at the site.

11.5.3 Any part of CONTRACTOR's capital expenses, including interest on CONTRACTOR's capital employed for the Work and charges against CONTRACTOR for delinquent payments.

11.5.4 Cost of premiums for all Bonds and for all insurance whether or not CONTRACTOR is required by the Contract Documents to purchase and maintain the same (except for the cost of premiums covered by subparagraph 11.4.5.9 above).

11.5.5 Costs due to the negligence of CONTRACTOR, any Subcontractor, or anyone directly or indirectly employed by any of them or for whose acts any of them may be liable, including but not limited to, the correction of defective Work, disposal of materials or equipment wrongly supplied and making good any damage to property, other overhead or general expense costs of any kind and the costs of any item not specifically and expressly included in paragraph 11.4.

11.6 The CONTRACTOR's fee allowed to CONTRACTOR for overhead and profit shall be determined as follows:

11.6.1 a mutually acceptable fixed fee; or

11.6.2 if a fixed fee is not agreed upon, then a fee based on the following percentages of the various portions of the Cost of the Work:

11.6.2.1 for costs incurred under paragraphs 11.4.1 and 11.4.2, the CONTRACTOR's fee shall be fifteen percent;

11.6.2.2 for costs incurred under paragraph 11.4.3, the CONTRACTOR's fee shall be five percent.

11.6.2.3 where one or more tiers of subcontracts are on the basis of Cost of the Work plus a fee and no fixed fee is agreed upon, the intent of paragraphs 11.4.1, 11.4.2, 11.4.3 and 11.6.2 is that the Subcontractor who actually performs or furnishes the Work, at whatever tier, will be paid a fee of fifteen percent of the costs incurred by such Subcontractor under paragraphs 11.4.1 and 11.4.2 and that any higher tier Subcontractor and CONTRACTOR will each be paid a fee of five percent of the amount paid to the next lower tier Subcontractor:

11.6.2.4 no fee shall be payable on the basis of costs itemized under paragraphs 11.4.4, 11.4.5 and 11.5;

11.6.2.5 the amount of credit to be allowed by CONTRACTOR to OWNER for any change which results in a net decrease in cost will be the amount of the actual net decrease in cost plus a deduction in CONTRACTOR's fee by an amount equal to five percent of such net decrease; and

11.6.2.6 when both additions and credits are involved in any one change, the adjustment in CONTRACTOR's fee shall be computed on the basis of the net change in accordance with paragraphs 11.6.2.1 through 11.6.2.5, inclusive.

11.7 Whenever the cost of any work is to be determined pursuant to paragraphs 11.4 and 11.5, CONTRACTOR will establish and maintain records thereof in accordance with generally accepted accounting practices and submit in form acceptable to ENGINEER an itemized cost breakdown together with supporting data.

Cash Allowances:

11.8 It is understood that CONTRACTOR has included in the Contract Price all allowances so named in the Contract Documents and shall cause the Work so covered to be furnished and performed for such sums as may be acceptable to OWNER and ENGINEER, CONTRACTOR agrees that:

11.8.1 the allowances include the cost to CONTRACTOR (less any applicable trade discounts) of materials and equipment required by the allowances to be delivered at the site, and all applicable taxes; and

11.8.2 CONTRACTOR's costs for unloading and handling on the site, labor, installation costs, overhead, profit and other expenses contemplated for the allowances have been included in the Contract Price and not in the allowances and no demand for additional payment on account of any of the foregoing will be valid.

Prior to final payment, an appropriate Change Order will be issued as recommended by ENGINEER to reflect actual amounts due CONTRACTOR on account of Work covered by allowances, and the Contract Price shall be correspondingly adjusted.

11.9 Unit Price Work:

11.9.1 Where the Contract Documents provide that all or part of the Work is to be Unit Price Work, initially the Contract Price will be deemed to include for all Unit Price Work an amount equal to the sum of the established unit price for each separately identified item of Unit Price Work times the estimated quantity of each item as indicated in the Agreement. The estimated quantities of items of Unit Price Work are not guaranteed and are solely for the purpose of comparison of Bids and determining an initial Contract Price. Determinations of the actual quantities and classifications of Unit Price Work performed by CONTRACTOR will be made by ENGINEER in accordance with paragraph 9.10.

11.9.2 Each unit price will be deemed to include an amount considered by CONTRACTOR to be adequate to cover CONTRACTOR's overhead and profit for each separately identified item.

11.9.3 OWNER or CONTRACTOR may make a claim for an adjustment in the Contract Price in accordance with Article 11 if:

11.9.3.1 the quantity of any item of Unit Price Work performed by CONTRACTOR differs materially and significantly from the estimated quantity of such item indicated in the Agreement; and

11.9.3.2 there is no corresponding adjustment with respect to any other item of Work; and

11.9.3.3 if CONTRACTOR believes that CONTRACTOR is entitled to an increase in Contract Price as a result of having incurred additional expense or OWNER believes that OWNER is entitled to a decrease in Contract Price and the parties are unable to agree as to the amount of any such increase or decrease.

ARTICLE 12 - CHANGE OF CONTRACT TIMES

12.1 The Contract Times (or Milestones) may only be changed by a Change Order or a Written Amendment. Any claim for an adjustment of the Contract Times (or Milestones) shall be based on written notice delivered by the party making the claim to the other party and to ENGINEER promptly (but in no event later than thirty days) after the occurrence of the event giving rise to the claim and stating the general nature of the claim. Notice of the extent of the claim with supporting data shall be delivered within sixty days after such occurrence (unless ENGINEER allows an additional period of time to ascertain more accurate data in support of the claim) and shall be accompanied by the claimant's written statement that the adjustment claimed is the entire adjustment to which the claimant has reason to believe it is entitled as a result of the occurrence of said event. All claims for adjustment in the Contract Times (or Milestones) shall be determined by ENGINEER in accordance with paragraph 9.11 if OWNER and CONTRACTOR cannot otherwise agree. No claim for an adjustment in the Contract Times (or Milestones) will be valid if not submitted in accordance with the requirements of this paragraph 12.1.

12.2 All time limits stated in the Contract Documents are of the essence of the Agreement.

12.3 Where CONTRACTOR is prevented from completing any part of the Work within the Contract Times (or Milestones) due to delay beyond the control of CONTRACTOR, the Contract Times (or Milestones) will be extended in an amount equal to the time lost due to such delay if a claim is made therefore as provided in paragraph 12.1. Delays beyond the

control of CONTRACTOR shall include, but not be limited to, acts or neglect by OWNER, acts or neglect of utility owners or other contractors performing other work as contemplated by Article 7, fires, floods, epidemics, abnormal weather conditions or acts of God. Delays attributable to and within the control of a Subcontractor or Supplier shall be deemed to be delays within the control of CONTRACTOR.

12.4 Where CONTRACTOR is prevented from completing any part of the Work within the Contract Times (or Milestones) due to delay beyond the control of both OWNER and CONTRACTOR, an extension of the Contract Times (or Milestones) in an amount equal to the time lost due to such delay shall be CONTRACTOR's sole and exclusive remedy for such delay. In no event shall OWNER be liable to CONTRACTOR, any Subcontractor, any Supplier, any other person or organization, or to any surety for or employee or agent of any of them, for damages arising out of or resulting from (i) delays caused by or within the control of CONTRACTOR, or (ii) delays beyond the control of both parties including but not limited to fires, floods, epidemics, abnormal weather conditions, acts of God or acts or neglect by utility owners or other contractors performing other work as contemplated by Article 7.

ARTICLE 13 - TESTS AND INSPECTION: CORRECTION, REMOVAL OR ACCEPTANCE OF DEFECTIVE WORK

13.1 **Notice of Defects:** Prompt notice of all defective Work of which OWNER or ENGINEER have actual knowledge will be given to CONTRACTOR. All defective Work may be rejected, corrected or accepted as provided in this Article 13.

Access to Work:

13.2 OWNER, ENGINEER, ENGINEER's Consultants, other representatives and personnel of OWNER, independent testing laboratories and governmental agencies with jurisdictional interests will have access to the Work at reasonable times for their observation, inspecting and testing. CONTRACTOR shall provide them proper and safe conditions for such access and advise them of CONTRACTOR's site safety procedures and programs so that they may comply therewith as applicable.

Tests and Inspections:

13.3 CONTRACTOR shall give ENGINEER timely notice of readiness of the Work for all required inspections, tests or approvals, and shall cooperate with

inspection and testing personnel to facilitate required inspections or tests.

13.4 OWNER shall employ and pay for the services of an independent testing laboratory to perform all inspections, tests, or approvals required by the Contract Documents except:

13.4.1 for inspections, tests or approvals covered by paragraph 13.5 below:

13.4.2 that costs incurred in connection with tests or inspections conducted pursuant to paragraph 13.9 below shall be paid as provided in said paragraph 13.9; and

13.4.3 as otherwise specifically provided in the Contract Documents.

13.5 If Laws or Regulations of any public body having jurisdiction require any Work (or part thereof) specifically to be inspected, tested or approved by an employee or other representative of such public body, CONTRACTOR shall assume full responsibility for arranging and obtaining such inspections, tests or approvals, pay all costs in connection therewith, and furnish ENGINEER the required certificates of inspection, or approval. CONTRACTOR shall also be responsible for arranging and obtaining and shall pay all costs in connection with any inspections, tests or approvals required for OWNER's and ENGINEER's acceptance of materials or equipment to be incorporated in the Work, or of materials, mix designs, or equipment submitted for approval prior to CONTRACTOR's purchase thereof for incorporation in the Work.

13.6 If any Work (or the work of others) that is to be inspected, tested or approved is covered by CONTRACTOR without written concurrence of ENGINEER, it must, if requested by ENGINEER, be uncovered for observation.

13.7 Uncovering Work as provided in paragraph 13.6 shall be at CONTRACTOR's expense unless CONTRACTOR has given ENGINEER timely notice of CONTRACTOR's intention to cover the same and ENGINEER has not acted with reasonable promptness in response to such notice.

Uncovering Work:

13.8 If any Work is covered contrary to the written request of ENGINEER, it must, if requested by ENGINEER, be uncovered for ENGINEER's observation and replaced at CONTRACTOR's expense.

13.9 If ENGINEER considers it necessary or advisable that covered Work be observed by ENGINEER or inspected or tested by others, CONTRACTOR, at ENGINEER's request, shall uncover, expose or otherwise make available for observation, inspection or testing as ENGINEER may require that portion of the Work in question, furnishing all necessary labor, material and equipment. If it is found that such Work is defective, CONTRACTOR shall pay all claims, costs, losses and damages caused by, arising out of or resulting from such uncovering, exposure, observation, inspection and testing and of satisfactory replacement or reconstruction (including but not limited to all costs of repair or replacement of work of others; and OWNER shall be entitled to an appropriate decrease in the Contract Price, and, if the parties are unable to agree as to the amount thereof, may make a claim therefore as provided in Article 11. If, however, such Work is not found to be defective, CONTRACTOR shall be allowed an increase in the Contract Price or an extension of the Contract Times (or Milestones), or both, directly attributable to such uncovering, exposure, observation, inspection, testing, replacement and reconstruction; and, if the parties are unable to agree as to the amount or extent thereof, CONTRACTOR may make a claim therefore as provided in Articles 11 and 12.

OWNER May Stop the Work:

13.10 If the Work is defective, or CONTRACTOR fails to supply sufficient skilled workers or suitable materials or equipment, or fails to furnish or perform the Work in such a way that the completed Work will conform to the Contract Documents. OWNER may order CONTRACTOR to stop the Work, or any portion thereof, until the cause for such order has been eliminated; however, this right of OWNER to stop the Work shall not give rise to any duty on the part of OWNER to exercise this right for the benefit of CONTRACTOR or any surety or other party.

Correction or Removal of Defective Work:

13.11 If required by ENGINEER, CONTRACTOR shall promptly, as directed, either correct all defective Work, whether or not fabricated, installed or completed, or, if the Work has been rejected by ENGINEER, remove it from the site and replace it with Work that is not defective. CONTRACTOR shall pay all claims, costs, losses and damages caused by or resulting from such correction or removal (including but not limited to all costs of repair or replacement of work of others).

13.12 Correction Period:

13.12.1 If within one year after the date of Substantial Completion or such longer period of time as may be prescribed by Laws or Regulations or by the terms of any applicable special guarantee required by the Contract Documents or by any specific provision of the Contract Documents, any Work is found to be defective, CONTRACTOR shall promptly, without cost to OWNER and in accordance with OWNER's written instruction: (i) correct such defective Work, or, if it has been rejected by OWNER, remove it from the site and replace it with Work that is not defective, and (ii) satisfactorily correct or remove and replace any damage to other Work or the work of others resulting therefrom. If CONTRACTOR does not promptly comply with the terms of such instructions, or in any emergency where delay would cause serious risk of loss or damage, OWNER may have the defective Work corrected or the rejected Work removed and replaced, and all claims, costs, losses and damages caused by or resulting from such removal and replacement (including but not limited to all costs of repair or replacement of work of others) will be paid by CONTRACTOR.

13.12.2 In special circumstances where a particular item of equipment is placed in continuous service before Substantial Completion of all the Work, the correction period for that item may start to run from an earlier date if so provided in the Specifications or by Written Amendment.

13.12.3 Where defective Work (and damage to other Work resulting therefrom) has been corrected, removed or replaced under this paragraph 13.12, the correction period hereunder with respect to such Work will be extended for an additional period of one year after such correction or removal and replacement has been satisfactorily completed.

Acceptance of Defective Work:

13.13 If instead of requiring correction or removal and replacement of defective Work, OWNER (and, prior to ENGINEER's recommendation of final payment, also ENGINEER) prefers to accept it, OWNER may do so. CONTRACTOR shall pay all claims, costs, losses and damages attributable to OWNER's evaluation of and determination to accept such defective Work (such costs to be approved by ENGINEER as to reasonableness). If any such acceptance occurs prior to ENGINEER's recommendation of final payment, a Change Order will be issued incorporating the necessary revisions in the Contract Documents with respect to the Work; and OWNER shall be entitled to an appropriate decrease in

the Contract Price, and, if the parties are unable to agree as to the amount thereof, OWNER may make a claim therefore as provided in Article 11. If the acceptance occurs after such recommendation, an appropriate amount will be paid by CONTRACTOR to OWNER.

OWNER May Correct Defective Work:

13.14 If CONTRACTOR fails within a reasonable time after written notice from ENGINEER to correct defective Work or to remove and replace rejected Work as required by ENGINEER in accordance with paragraph 13.11, or if CONTRACTOR fails to perform the Work in accordance with the Contract Documents, or if CONTRACTOR fails to comply with any other provision of the Contract Documents, OWNER may, after seven days' written notice to CONTRACTOR, correct and remedy any such deficiency. In exercising the rights and remedies under this paragraph OWNER shall proceed expeditiously. In connection with such corrective and remedial action, OWNER may exclude CONTRACTOR from all or part of the site, take possession of all or part of the Work, and suspend CONTRACTOR's services related thereto, take possession of CONTRACTOR's tools, appliances, construction equipment and machinery at the site and incorporate in the Work all materials and equipment stored at the site or for which OWNER has paid CONTRACTOR but which are stored elsewhere. CONTRACTOR shall allow OWNER, OWNER's representative, agents and employees, OWNER's other contractors and ENGINEER and ENGINEER's Consultants access to the site to enable OWNER to exercise the rights and remedies under this paragraph. All claims, costs, losses and damages incurred or sustained by OWNER in exercising such rights and remedies will be charged against CONTRACTOR and a Change Order will be issued incorporating the necessary revisions in the Contract Documents with respect to the Work; and OWNER shall be entitled to an appropriate decrease in the Contract Price, and, if the parties are unable to agree as to the amount thereof, OWNER may make a claim therefore as provided in Article 11. Such claims, costs, losses and damages will include but not be limited to all costs of repair or replacement of work of others destroyed or damaged by correction, removal or replacement of CONTRACTOR's defective Work. CONTRACTOR shall not be allowed an extension of the Contract Times (or Milestones) because of any delay in the performance of the Work attributable to the exercise by OWNER of OWNER's rights and remedies hereunder.

ARTICLE 14 - PAYMENTS TO CONTRACTOR AND COMPLETION

Schedule of Values:

14.1 The schedule of values established as provided in paragraph 2.9 will serve as the basis for progress payments and will be incorporated into a form of Application for Payment acceptable to ENGINEER. Progress payments on account of Unit Price Work will be based on the number of units completed.

Application for Progress Payment:

14.2 At least twenty days before the date established for each progress payment (but not more often than once a month), CONTRACTOR shall submit to ENGINEER for review an Application for Payment filled out and signed by CONTRACTOR covering the Work completed as of the date of the Application and accompanied by such supporting documentation as is required by the Contract Documents. If payment is requested on the basis of materials and equipment not incorporated in the Work but delivered and suitably stored at the site or at another location agreed to in writing, the Application for Payment shall also be accompanied by a bill of sale, invoice or other documentation warranting that OWNER has received the materials and equipment free and clear of all Liens and evidence that the materials and equipment are covered by appropriate property insurance and other arrangements to protect OWNER's interest therein, all of which will be satisfactory to OWNER. The amount of retainage with respect to progress payments will be as stipulated in the Agreement.

CONTRACTOR's Warranty of Title:

14.3 CONTRACTOR warrants and guarantees that title to all Work, materials and equipment covered by any Application for Payment, whether incorporated in the Project or not, will pass to OWNER no later than the time of payment free and clear of all Liens.

Review of Applications for Progress Payment:

14.4 ENGINEER will, within ten days after receipt of each Application for Payment, either indicate in writing a recommendation of payment and present the Application to OWNER, or return the Application to CONTRACTOR indicating in writing ENGINEER's reasons for refusing to recommend payment. In the latter case, CONTRACTOR may make the necessary corrections and resubmit the Application. Ten days after presentation of the Application for Payment to OWNER with ENGINEER's recommendation, the amount recommended will (subject to the provisions of

the last sentence of paragraph 14.7) become due and when due will be paid by OWNER to CONTRACTOR.

14.5 ENGINEER's recommendation of any payment requested in an Application for Payment will constitute a representation by ENGINEER to OWNER, based on ENGINEER's on-site observations of the executed Work as an experienced and qualified design professional and on ENGINEER's review of the Application for Payment and the accompanying data and schedules, that to the best of ENGINEER's knowledge, information and belief:

14.5.1 the Work has progressed to the point indicated.

14.5.2 the quality of the Work is generally in accordance with the Contract Documents (subject to an evaluation of the Work as a functioning whole prior to or upon Substantial Completion, to the results of any subsequent tests called for in the Contract Documents, to a final determination of quantities and classifications for Unit Price Work under paragraph 9.10, and to any other qualifications stated in the recommendation), and 14.5.3 the conditions precedent to CONTRACTOR's being entitled to such payment appear to have been fulfilled in so far as it is ENGINEER's responsibility to observe the Work.

However, by recommending any such payment ENGINEER will not thereby be deemed to have represented that: (i) exhaustive or continuous on-site inspections have been made to check the quality or the quantity of the Work beyond the responsibilities specifically assigned to ENGINEER in the Contract Documents or (ii) that there may not be other matters or issues between the parties that might entitle CONTRACTOR to be paid additionally by OWNER or entitle OWNER to withhold payment to CONTRACTOR.

14.6 ENGINEER's recommendation of any payment, including final payment, shall not mean that ENGINEER is responsible for CONTRACTOR's means, methods, techniques, sequences or procedures of construction, or the safety precautions and programs incident thereto, or for any failure of CONTRACTOR to comply with Laws and Regulations applicable to the furnishing or performance of Work, or for any failure of CONTRACTOR to perform or furnish Work in accordance with the Contract Documents.

14.7 ENGINEER may refuse to recommend the whole or any part of any payment if, in ENGINEER's opinion, it would be incorrect to make the representations to OWNER referred to in paragraph 14.5. ENGINEER may also refuse to recommend any

such payment, or, because of subsequently discovered evidence or the results of subsequent inspections or tests, nullify any such payment previously recommended, to such extent as may be necessary in ENGINEER's opinion to protect OWNER from loss because:

14.7.1 the Work is defective, or completed Work has been damaged requiring correction or replacement.

14.7.2 the Contract Price has been reduced by Written Amendment or Change Order.

14.7.3 OWNER has been required to correct defective Work or complete Work in accordance with paragraph 13.14. or

14.7.4 ENGINEER has actual knowledge of the occurrence of any of the events enumerated in paragraphs 15.2.1 through 15.2.4 inclusive.

OWNER may refuse to make payment of the full amount recommended by ENGINEER because:

14.7.5 claims have been made against OWNER on account of CONTRACTORs performance or furnishing of the Work.

14.7.6 liens have been filed in connection with the Work, except where CONTRACTOR has delivered a specific Bond satisfactory to OWNER to secure the satisfaction and discharge of such Liens,

14.7.7 there are other items entitling OWNER to a set-off against the amount recommended, or

14.7.8 OWNER has actual knowledge of the occurrence of any of the events enumerated in paragraphs 14.7.1 through 14.7.3 or paragraphs 15.2.1 through 15.2.4 inclusive;

but OWNER must give CONTRACTOR immediate written notice (with a copy to ENGINEER) stating the reasons for such action and promptly pay CONTRACTOR the amount so withheld, or any adjustment thereto agreed to by OWNER and CONTRACTOR, when CONTRACTOR corrects to OWNER's satisfaction the reasons for such action.

Substantial Completion:

14.8 When CONTRACTOR considers the entire Work ready for its intended use CONTRACTOR shall notify OWNER and ENGINEER in writing that the entire Work is substantially complete (except for items specifically listed by CONTRACTOR as incomplete) and request that ENGINEER issue a certificate of

Substantial Completion. Within a reasonable time thereafter, OWNER, CONTRACTOR and ENGINEER shall make an inspection of the Work to determine the status of completion. If ENGINEER does not consider the Work substantially complete, ENGINEER will notify CONTRACTOR in writing giving the reasons therefore. If ENGINEER considers the Work

substantially complete, ENGINEER will prepare and deliver to OWNER a tentative certificate of Substantial Completion which shall fix the date of Substantial Completion. There shall be attached to the certificate a tentative list of items to be completed or corrected before final payment. OWNER shall have seven days after receipt of the tentative certificate during which to make written objection to ENGINEER as to any provisions of the certificate or attached list. If, after considering such objections, ENGINEER concludes that the Work is not substantially complete, ENGINEER will within fourteen days after submission of the tentative certificate to OWNER notify CONTRACTOR in writing, stating the reasons therefore. If, after consideration of OWNER's objections, ENGINEER considers the Work substantially complete, ENGINEER will within said fourteen days execute and deliver to OWNER and CONTRACTOR a definitive certificate of Substantial Completion (with a revised tentative list of items to be completed or corrected) reflecting such changes from the tentative certificate as ENGINEER believes justified after consideration of any objections from OWNER. At the time of delivery of the tentative certificate of Substantial Completion ENGINEER will deliver to OWNER and CONTRACTOR a written recommendation as to division of responsibilities pending final payment between OWNER and CONTRACTOR with respect to security, operation, safety, maintenance, heat, utilities, insurance and warranties and guarantees. Unless OWNER and CONTRACTOR agree otherwise in writing and so inform ENGINEER in writing prior to ENGINEER's issuing the definitive certificate of Substantial Completion, ENGINEER's aforesaid recommendation will be binding on OWNER and CONTRACTOR until final payment.

14.9 OWNER shall have the right to exclude CONTRACTOR from the Work after the date of Substantial Completion, but OWNER shall allow CONTRACTOR reasonable access to complete or correct items on the tentative list.

Partial Utilization:

14.10 Use by OWNER at OWNER's option of any substantially completed part of the Work which: (i) has specifically been identified in the Contract Documents, or (ii) OWNER, ENGINEER and CONTRACTOR agree constitutes a separately functioning and usable

part of the Work that can be used by OWNER for its intended purpose without significant interference with CONTRACTOR's performance of the remainder of the Work, may be accomplished prior to Substantial Completion of all the Work subject to the following:

14.10.1 OWNER at any time may request CONTRACTOR in writing to permit OWNER to use any such part of the Work which OWNER believes to be ready for its intended use and substantially complete. If CONTRACTOR agrees that such part of the Work is substantially complete, CONTRACTOR will certify to OWNER and ENGINEER that such part of the Work is substantially complete and request ENGINEER to issue a certificate of Substantial Completion for that part of the Work. CONTRACTOR at any time may notify OWNER and ENGINEER in writing that CONTRACTOR considers any such part of the Work ready for its intended use and substantially complete and request ENGINEER to issue a certificate of Substantial Completion for that part of the Work. Within a reasonable time after either such request, OWNER, CONTRACTOR and ENGINEER shall make an inspection of that part of the Work to determine its status of completion. If ENGINEER does not consider that part of the Work to be substantially complete, ENGINEER will notify OWNER and CONTRACTOR in writing giving the reasons therefore. If ENGINEER considers that part of the Work to be substantially complete, the provisions of paragraphs 14.8 and 14.9 will apply with respect to certification of Substantial Completion of that part of the Work and the division of responsibility in respect thereof and access thereto.

14.10.2 No occupancy or separate operation of part of the Work will be accomplished prior to compliance with the requirements of paragraph 5.13 in respect of property insurance.

Final Inspection:

14.11 Upon written notice from CONTRACTOR that the entire Work or an agreed portion thereof is complete, ENGINEER will make a final inspection with OWNER and CONTRACTOR and will notify CONTRACTOR in writing of all particulars in which this inspection reveals that the Work is incomplete or defective. CONTRACTOR shall immediately take such measures as are necessary to complete such Work or remedy such deficiencies.

Final Application for Payment:

14.12 After CONTRACTOR has completed all such corrections to the satisfaction of ENGINEER and delivered in accordance with the Contract Documents

all maintenance and operating instructions, schedules, guarantees, Bonds, certificates or other evidence of insurance required by Article 5, certificates of inspection, marked-up record documents (as provided in paragraph 6.19) and other documents, CONTRACTOR may make application for final payment following the procedure for progress payments. The final Application for Payment shall be accompanied (except as previously delivered) by: (i) all documentation called for in the Contract Documents, including but not limited to the evidence of insurance required by Article 5, (ii) consent of the surety, if any, to final payment, and (iii) complete and legally effective releases or waivers (satisfactory to OWNER) of all Liens arising out of or filed in connection with the Work. In lieu of such releases or waivers of Liens and as approved by OWNER, CONTRACTOR may furnish receipts or releases in full and an affidavit of CONTRACTOR that: (i) the releases and receipts include all labor, services, material and equipment for which a Lien could be filed, and (ii) all payrolls, material and equipment bills and other indebtedness connected with the Work for which OWNER or OWNER's property might in any way be responsible have been paid or otherwise satisfied. If any Subcontractor or Supplier fails to furnish such a release or receipt in full, CONTRACTOR may furnish a Bond or other collateral satisfactory to OWNER to indemnify OWNER against any Lien.

Final Payment and Acceptance:

14.13 If, on the basis of ENGINEER's observation of the Work during construction and final inspection, and ENGINEER's review of the final application for Payment and accompanying documentation as required by the Contract Documents, ENGINEER is satisfied that the Work has been completed and CONTRACTOR's other obligations under the Contract Documents have been fulfilled, ENGINEER will, within ten days after receipt of the final Application for Payment, indicate in writing ENGINEER's recommendation of payment and present the Application to OWNER for payment. At the same time ENGINEER will also give written notice to OWNER and CONTRACTOR that the Work is acceptable subject to the provisions of paragraph 14.15. Otherwise, ENGINEER will return the Application to CONTRACTOR, indicating in writing the reasons for refusing to recommend final payment, in which case CONTRACTOR shall make the necessary corrections and resubmit the Application. Thirty days after the presentation to OWNER of the Application and accompanying documentation, in appropriate form and substance and with ENGINEER's recommendation and notice of acceptability, the amount recommended by

ENGINEER will become due and will be paid by OWNER to CONTRACTOR

14.14 If, through no fault of CONTRACTOR, final completion of the Work is significantly delayed and if ENGINEER so confirms, OWNER shall, upon receipt of CONTRACTOR's final Application for Payment and recommendation of ENGINEER, and without terminating the Agreement, make payment of the balance due for that portion of the Work fully completed and accepted. If the remaining balance to be held by OWNER for Work not fully completed or corrected is less than the retainage stipulated in the Agreement, and if Bonds have been furnished as required in Article 5, the written consent of the surety to the payment of the balance due for that portion of the Work fully completed and accepted shall be submitted by CONTRACTOR to ENGINEER with the Application for such payment. Such payment shall be made under the terms and conditions governing final payment, except that it shall not constitute a waiver of claims.

Waiver of Claims:

14.15 The making and acceptance of final payment will constitute:

14.15.1 a waiver of all claims by OWNER against CONTRACTOR, except claims arising from unsettled Liens, from defective Work appearing after final inspection pursuant to paragraph 14.11, from failure to comply with the Contract Documents or the terms of any special guarantees specified therein, or from CONTRACTOR's continuing obligations under the Contract Documents; and

14.15.2 a waiver of all claims by CONTRACTOR against OWNER other than those previously made in writing and still unsettled.

ARTICLE 15 - SUSPENSION OF WORK AND TERMINATION

OWNER May Suspend Work:

15.1 At any time and without cause, OWNER may suspend the Work or any portion thereof for a period of not more than ninety days by notice in writing to CONTRACTOR and ENGINEER which will fix the date on which Work will be resumed. CONTRACTOR shall resume the Work on the date so fixed. CONTRACTOR shall be allowed an adjustment in the Contract Price or an extension of the Contract Times, or both, directly attributable to any such

suspension if CONTRACTOR makes an approved claim therefore as provided in Articles 11 and 12.

OWNER May Terminate:

15.2 Upon the occurrence of any one or more of the following events:

15.2.1 if CONTRACTOR persistently fails to perform the Work in accordance with the Contract Documents (including, but not limited to, failure to supply sufficient skilled workers or suitable materials or equipment or failure to adhere to the progress schedule established under paragraph 2.9 as adjusted from time to time pursuant to paragraph 6.6);

15.2.2 if CONTRACTOR disregards Laws or Regulations of any public body having jurisdiction;

15.2.3 if CONTRACTOR disregards the authority of ENGINEER; or

15.2.4 if CONTRACTOR otherwise violates in any substantial way any provisions of the Contract Documents;

OWNER may, after giving CONTRACTOR (and the surety, if any,) seven days' written notice and to the extent permitted by Laws and Regulations, terminate the services of CONTRACTOR, exclude CONTRACTOR from the site and take possession of the Work and of all CONTRACTOR's tools, appliances, construction equipment and machinery at the site and use the same to the full extent they could be used by CONTRACTOR (without liability to CONTRACTOR for trespass or conversion), incorporate in the Work all materials and equipment stored at the site or for which OWNER has paid CONTRACTOR but which are stored elsewhere, and finish the Work as OWNER may deem expedient. In such case CONTRACTOR shall not be entitled to receive any further payment until the Work is finished. If the unpaid balance of the Contract Price exceeds all claims, costs, losses and damages sustained by OWNER arising out of or resulting from completing the Work such excess will be paid to CONTRACTOR. If such claims, costs, losses and damages exceed such unpaid balance, CONTRACTOR shall pay the difference to OWNER. Such claims, costs, losses and damages incurred by OWNER will be reviewed by ENGINEER as to their reasonableness and when so approved by ENGINEER incorporated in a Change Order, provided that when exercising any rights or remedies under this paragraph OWNER shall not be required to obtain the lowest price for the Work performed.

15.3 Where CONTRACTOR's services have been so terminated by OWNER, the termination will not affect any rights or remedies of OWNER against CONTRACTOR then existing or which may thereafter accrue. Any retention or payment of moneys due CONTRACTOR by OWNER will not release CONTRACTOR from liability.

15.4 Upon seven days' written notice to CONTRACTOR and ENGINEER, OWNER may, without cause and without prejudice to any other right or remedy of OWNER, elect to terminate the Agreement. In such case, CONTRACTOR shall be paid (without duplication of any items):

15.4.1 for completed and acceptable Work executed in accordance with the Contract Documents prior to the effective date of termination, including fair and reasonable sums for overhead and profit on such Work;

15.4.2 for expenses sustained prior to the effective date of termination in performing services and furnishing labor, materials or equipment as required by the Contract Documents in connection with uncompleted Work, plus fair and reasonable sums for overhead and profit on such expenses;

15.4.3 for all claims, costs, losses and damages incurred in settlement of terminated contracts with Subcontractors, Suppliers and other; and

15.4.4 for reasonable expenses directly attributable to termination.

CONTRACTOR shall not be paid on account of loss of anticipated profits or revenue or other economic loss arising out of or resulting from such termination.

CONTRACTOR May Stop Work or Terminate:

15.5 If, through no act or fault of CONTRACTOR, the Work is suspended for a period of more than ninety days by OWNER or under an order of court or other public authority, or ENGINEER fails to act on any Application for Payment within thirty days after it is submitted or OWNER fails for thirty days to pay CONTRACTOR any sum finally determined to be due, then CONTRACTOR may, upon seven days' written notice to OWNER and ENGINEER, and provided OWNER or ENGINEER do not remedy such suspension or failure within that time, terminate the Agreement and recover from OWNER payment on the same terms as provided in paragraph 15.4. In lieu of terminating the Agreement and without prejudice to any other right or remedy, if ENGINEER has failed to act on an Application for Payment within thirty days after it is submitted, or OWNER has failed for thirty days to pay CONTRACTOR any sum finally

determined to be due, CONTRACTOR may upon seven day's written notice to OWNER and ENGINEER stop the Work until payment of all such amounts due CONTRACTOR, including interest thereon. The provisions of this paragraph 15.5 are not intended to preclude CONTRACTOR from making claim under Articles 11 and 12 for an increase in Contract Price or Contract Times or otherwise for expenses or damage directly attributable to CONTRACTOR's stopping Work as permitted by this paragraph.

ARTICLE 16 - DISPUTE RESOLUTION

If and to the extent that OWNER and CONTRACTOR have agreed on the method and procedure for resolving disputes between them that may arise under this Agreement, such dispute resolution method and procedure, if any, shall be as set forth in Exhibit GC-A, "Dispute Resolution Agreement," to be attached hereto and made a part hereof. If no such agreement on the method and procedure for resolving such disputes has been reached, and subject to the provisions of paragraphs 9.10, 9.11, and 9.12, OWNER and CONTRACTOR may exercise such rights or remedies as either may otherwise have under the Contract Documents or by Laws or Regulations in respect of any dispute.

ARTICLE 17 - MISCELLANEOUS

Giving Notice:

17.1 Whenever any provision of the Contract Documents requires the giving of written notice, it will be deemed to have been validly given if delivered in person to the individual or to a member of the firm or to an officer of the corporation for whom it is intended, or if delivered at or sent by registered or certified mail, postage prepaid, to the last business address known to the giver of the notice.

Computation of Times:

17.2 When any period of time is referred to in the Contract Documents by days, it will be computed to exclude the first and include the last day of such period. If the last day of any such period falls on a Saturday or Sunday or on a day made a legal holiday by the law of the applicable jurisdiction, such day will be omitted from the computation.

17.2.1 A calendar day of twenty-four hours measured from midnight to the next midnight will constitute a day.

Notice of Claim:

17.3 Should OWNER or CONTRACTOR suffer injury or damage to person or property because of any error, omission or act of the other part or of any of the other party's employees or agents or others for whose acts the other party is legally liable, claim will be made in writing to the other party within a reasonable time of the first observance of such injury or damage. The provisions of this paragraph 17.3 shall not be construed as a substitute for or a waiver of the provisions of any applicable statute of limitations or repose.

Cumulative Remedies:

17.4 The duties and obligations imposed by these General Conditions and the rights and remedies available hereunder to the parties hereto, and, in particular but without limitation, the warranties, guarantees and obligations imposed upon CONTRACTOR by paragraphs 6.12, 6.16, 6.30, 6.31,

6.32, 13.1, 13.12, 13.14, 14.3 and 15.2 and all of the rights and remedies available to OWNER and ENGINEER thereunder, are in addition to, and are not to be construed in any way as a limitation of, any rights and remedies available to any or all of them which are otherwise imposed or available by Laws or Regulations, by special warranty or guarantee or by other provisions of the Contract Documents, and the provisions of this paragraph will be as effective as if repeated specifically in the Contract Documents in connection with each particular duty, obligation, right and remedy to which they apply.

Professional Fees and Court Costs Included:

17.5 Whenever reference is made to "claims, costs, losses and damages," it shall include in each case, but not be limited to, all fees and charges of engineers, architects, attorneys and other professionals and all court or arbitration or other dispute resolution costs.

DRAFT - NOT FOR CONSTRUCTION

**STANDARD FORM OF AGREEMENT
BETWEEN OWNER AND CONTRACTOR
ON THE BASIS OF A STIPULATED PRICE**

THIS AGREEMENT is dated as of the ___ day of _____ in the year 2014 by and between Vermont Gas Systems, Inc (hereinafter called OWNER) and Over & Under Piping Contractors, Inc. (hereinafter called CONTRACTOR).

OWNER and CONTRACTOR, in consideration of the mutual covenants hereinafter set forth, agree as follows:

ARTICLE 1 - WORK.

CONTRACTOR shall complete all Work as specified or indicated in the Contract Documents. The Work is generally described as follows:

PROPOSED SYSTEM EXPANSION – ADDISON NATURAL GAS PROJECT – TRANSMISSION MAIN

The Project for which the Work under the Contract Documents may be the whole or only a part is generally described as follows:

The installation of approximately 217,988 linear feet of OWNER supplied 12-inch gas transmission piping, and appurtenances, mainline valve sites, and other required work for a complete pipeline installation in accordance with all Drawings and Specifications and the provisions of Contract Documents.

ARTICLE 2 - ENGINEER.

The Project has been designed by CHA Consulting, Inc. who is hereinafter called ENGINEER.

CHA will act as OWNER's representative, assume all duties and responsibilities and have the rights and authority assigned to ENGINEER in the Contract Documents in connection with completion of the Work in accordance with the Contract Documents.

ARTICLE 3 - CONTRACT TIMES.

3.1 The Work will be substantially completed and put into operation on or before the dates established in Exhibit 1 to this Agreement.

ARTICLE 4 - CONTRACT PRICE.

OWNER shall pay CONTRACTOR for completion of the Work in accordance with the Contract Documents an amount equal to the sum of the amounts determined pursuant to paragraphs 4.1 below:

4.1 for all Work a Lump Sum of:

_____ (\$ _____)
(use words) (figures)

ARTICLE 5 - PAYMENT PROCEDURES.

CONTRACTOR shall submit Application for Payment in accordance with Article 14 of the General Conditions, Applications for Payment will be processed by ENGINEER as provided in the General Conditions.

5.1 *Progress Payments; Retainage.* OWNER shall make progress payments on account of the Contract Price on the basis of CONTRACTOR's Applications for Payment as recommended by ENGINEER, on a Net 30 day basis during construction as provided in paragraphs 5.1.1 and 5.1.2 below. All such payments will be measured by the schedule of values established in paragraph 2.9 of the General Conditions (an in the case of Unit Price Work based on the number of units completed) or, in the event there is no schedule of values, as provided in the General Requirements.

5.1.1. Retainage shall be in accordance with Exhibit 1.

5.2 *Final Payment.* Upon final completion and acceptance of the Work in accordance with paragraph 14.13 of the General Conditions, OWNER shall pay up to 95% of the Contract Price as recommended by ENGINEER as provided in said paragraph 14.13. A portion of the invoice amount (5% of the total value) will be retained until verification of satisfactory installation of all work and clean-up measures are completed. This amount can be retained up to one (1) year from the date of completion. Work that in the opinion of the verification inspector does not conform to VGS standards, is ineffective, or is not reasonably durable must be completed at CONTRACTOR's expense.

5.3 Bonus Payment – Bonus Payments will be paid on a Net 30 day basis during construction based on the Bonus Schedule provided in Exhibit 1.

ARTICLE 6 - CONTRACTOR'S REPRESENTATIONS.

In order to induce OWNER to enter into this Agreement CONTRACTOR makes the following representations:

6.1 CONTRACTOR has examined and carefully studied the Contract Documents (including the Addenda listed in paragraph 8) and the other related data identified in the Bidding Documents including "technical data."

6.2 CONTRACTOR has visited the site and become familiar with and is satisfied as to the general, local, and site conditions that may affect cost, progress, performance or furnishing of the Work.

6.3 CONTRACTOR is familiar with and is satisfied as to all federal, state, and local Laws and Regulations that may affect cost, progress, performance and furnishing of the Work.

6.4 CONTRACTOR has carefully studied all reports of explorations and tests of subsurface conditions at or contiguous to site and all drawings of physical conditions in or relating to existing surface or subsurface structures at or contiguous to the site (except Underground Facilities) which have been identified in the Supplementary Conditions as provided in paragraph 4.2.1 of the General Conditions. CONTRACTOR accepts the determination set forth in paragraph SC-4.2 of the Supplementary Conditions of the extent of the "technical data" contained in such reports and drawings upon which CONTRACTOR is entitled to rely as provided in paragraph 4.2 of the General Conditions, as supplemented in the Supplementary Conditions. CONTRACTOR acknowledges that such reports and drawings are not Contract Documents and may not be complete for CONTRACTOR's purposes. CONTRACTOR acknowledges that OWNER and ENGINEER do not assume responsibility for the accuracy or completeness of information and data shown or indicated in the Contract Documents with respect to Underground Facilities at or contiguous to the site. CONTRACTOR has obtained and carefully studied (or assumes responsibility for having done so) all such additional supplementary examinations, investigations, explorations, tests, studies, and data concerning conditions (surface, subsurface, and Underground Facilities) at or contiguous to the site or otherwise which may affect cost, progress, performance, or furnishing of the Work or which relate to any aspect of the means, methods, techniques, sequences, and procedures of construction to be employed by CONTRACTOR and safety precautions, and programs incident thereto. CONTRACTOR does not consider that any additional examinations, investigations, explorations, tests, studies, or data are necessary for the performance and furnishing of the Work at the Contract Price, within the Contract Times and in accordance with the other terms and conditions of the Contract Documents.

6.5 CONTRACTOR is aware of the general nature of work to be performed by OWNER and others at the site that relates to the Work as indicated in the Contract Documents.

6.6 CONTRACTOR has correlated the information known to CONTRACTOR, information and observation obtained from visits to the site, reports, and drawings identified in the Contract Documents and all additional examinations, investigations, explorations, tests, studies, and data with the Contract Documents.

6.7 CONTRACTOR has given ENGINEER written notice of all conflicts, errors, ambiguities or discrepancies that CONTRACTOR has discovered in the Contract Documents and the written resolution thereof by ENGINEER is acceptable to CONTRACTOR, and the Contract Documents are generally sufficient to indicate and convey understanding of all terms and conditions for performance and furnishing of the Work.

ARTICLE 7 - CONTRACT DOCUMENTS.

The Contract Documents which comprise the entire agreement between OWNER and CONTRACTOR concerning the Work consist of the following:

- 7.1 This Agreement (pages 1 to 5, inclusive).
- 7.2 General Conditions (pages GC-1 to GC-35, inclusive).
- 7.3 Supplemental Conditions (pages SC-1 to SC-10, inclusive), and all documents referenced therein as Contract Documents.
- 7.4 Specifications bearing the title "Proposed System Expansion – Addison Natural Gas Project Transmission Contract consisting of divisions and pages, as listed in table of contents thereof.
- 7.5 Exhibits to this Agreement (Exhibits may not be attached to this agreement, but form part of the contract):
 - 7.5.1 Exhibit 1 – "ANGP Phase I Main Line Construction Pricing Contract Notes/Adjustments" dated May 16, 2014
 - 7.5.2 Exhibit 2 – Drawing Sets consisting of the following. Refer to the Contract Document List for specific dates and revisions for each drawing.
 1. "Vermont Gas Proposed 12" Pipeline – Addison Natural Gas Project – Alignment Sheets – Issued for Construction" produced by CHA.
 2. "Vermont Gas Proposed 12" Pipeline – Addison Natural Gas Project – EPSC Plans – Issued for Construction" produced by VHB/CHA.
 3. "Colchester Launcher and Tie-In Site – Issued for Construction" produced by CHA.
 4. "Mainline Valve Typical-Issued for Bid" produced by CHA.
 5. "Williston Meter & Regulation Station – Issued for Construction" produced by CHA. Scope is for work outside of the M&R fenced area per Addendum 1
 6. "Plank Road Meter and Regulation Station – Issued for Construction" produced by CHA. Scope is for mainline valve (inside of the fenced area) and work outside of the fenced area per Addendum 1.
 7. "Middlebury Meter and Regulation Station – Issued for Construction" produced by CHA. Scope is for mainline valve (inside of the fenced area) and work outside of the fenced area per Addendum 1.
 8. "Vermont Gas Systems, Inc. – Addison Natural Gas Project – AC Mitigation System Design / Valve Site Grounding Installation Drawings" produced by ARK Engineering and Technical Services, Inc.
 9. "Vermont Gas Systems, Inc. – Addison Natural Gas Project – Zinc Ribbon Installation Drawings" produced by ARK Engineering and Technical Services, Inc.
 10. "Vermont Gas Systems, Inc. – Addison Natural Gas Project – Cathodic Protection System Design – Installation Drawings" produced by ARK Engineering and Technical Services, Inc.

- 7.6 Performance and Payment Bonds identified in the Project Manual
- 7.7 Addenda numbers 1 to 4, inclusive. Attachments to addendum are provided electronically and are contractual requirements.
- 7.8 Post Bid Bulletin numbers 1 to 4, inclusive. Attachments to post bid bulletins are provided electronically and are contractual requirements.
- 7.9 Documents listed in the Contract Document List of the Conformed Project Manual.
- 7.10 The following which may be delivered or issued after the Effective Date of the Agreement and are not attached hereto: All Written Amendments and other documents amending, modifying or supplementing the Contract Documents pursuant to paragraphs 3.5 and 3.6 of the General Conditions.

The documents listed in Article 7 above are attached to this Agreement (except as expressly noted otherwise above). Failure to attach any Contract Documents will not alter, amend, or void their terms, conditions, requirements, or provisions.

There are not Contract Documents other than those listed above in this Article 7. The Contract Documents may only be amended, modified or supplemented as provided in paragraphs 3.5 and 3.6 of the General Conditions.

ARTICLE 8 - MISCELLANEOUS.

8.1 Terms used in this Agreement which are defined in Article 1 of the General Conditions will have the meanings indicated in the General Conditions.

8.2 No assignment by a party hereto of any rights under or interests in the Contract Documents will be binding on another party hereto without the written consent of the party sought to be bound; and, specifically but without limitation, moneys that may become due and moneys that are due may not be assigned without such consent (except to the extent that the effect of this restriction may be limited by law), and unless specifically stated to the contrary in any written consent to an assignment no assignment will release or discharge the assignor from any duty or responsibility under the Contract Documents.

8.3 OWNER and CONTRACTOR each binds itself, its partners, successors, assigns and legal representatives to the other party hereto, its partners, successors, assigns and legal representatives in respect to all covenants, agreements, and obligations contained in the Contract Documents.

8.4 Any provisions or part of the Contract Documents held to be void or unenforceable under any Law or Regulation shall be deemed stricken, and all remaining provisions shall continue to be valid and binding upon OWNER and CONTRACTOR who agree that the Contract Documents shall be reformed to replace such stricken provision or part thereof with a valid and enforceable provision that comes as close as possible to expressing the intention of the stricken provision.

IN WITNESS WHEREOF, OWNER, and CONTRACTOR have signed this Agreement in triplicate. One counterpart each has been delivered to OWNER, CONTRACTOR, and ENGINEER. All portions of the Contract Documents have been signed, initialed or identified by OWNER, and CONTRACTOR, or identified by ENGINEER on their behalf.

This Agreement will be effective on _____, 20__ (which is the Effective Date of the Agreement).

OWNER _____

CONTRACTOR _____

By: _____

By: _____

[CORPORATE SEAL]

[CORPORATE SEAL]

Attest _____

Attest _____

Address for giving notices:

Address for giving notices:

License No. _____

Agent for services of process: _____

(If CONTRACTOR is a corporation, attach evidence of authority to sign).

DRAFT - NOT FOR CONSTRUCTION

ANGP_Phase I_Main Line Construction Pricing Contract Notes/Adjustments

The following items are modifications and clarifications to the Over and Under bid pricing provided to Vermont Gas. These adjustments reflect agreements reached by the parties during a meeting on Friday April 11, 2014 at VGS. The modifications supersede all previous correspondence and adjustments to the pricing and schedule.

Pricing Adjustments:

Description	Cost	Notes
Base Bid	\$ 35,188,299	Pricing includes 20,000 CY of sand bedding material
Alt #1 - Rock Removal	\$ 6,750,000	
ALT #2 - HDD Support	\$ 1,964,000	
Alt #4 - Essex RR Crossing	\$ 49,544	This alternate is included as an HDD by ECI with O/U providing support and pipe installation consistent with other HDD work.
Alt #5 - Williston RR Crossing	\$ 350,481	
Performance & Payment Bond	\$ 245,694	
Bending Mandrels	\$ -	O/U taking the risk on this item
PBB #1/#2		
1,700 additional mats	\$ 870,487	Based on delivered unit pricing of \$450/mat
- credit for mat washing	\$ (972,492)	Pay on a unit price basis - \$68.64/mat to pressure wash
Subcontractor Mob/Demob	\$ 37,000	This adjustment is for two construction seasons
O/U Mob/Demob Premium	\$ 248,521	This adjustment is for two construction seasons and includes the O/U 2015 labor rate adjustments
PBB #3		
Rocky Ridge Re-route - C-035	\$ 10,965	2/17/2014 Letter
LL#116 Thibault - C-094	\$ (3,315)	2/17/2014 Letter
Palmer Re-route	\$ 77,217	2/17/2014 Letter
Delete Access Road AL	\$ (4,445)	2/17/2014 Letter
Revised Mat Plan	\$ -	VGS to supply 1,700 mats in location designated by O/U
Revised Contract Date	\$ -	June 2 start
Sand bags ILO Pipe Pillows	\$ (128,353)	
Add A/C & CP w/ARK Eng	\$ 131,579	O/U is hiring ARK Engineering as a sub to O/U to install, including at M&R stations. VGS to supply the material.
PBB #4		
OSPC	\$ -	O/U is including in base contract
TNT Drug Consortium	\$ -	O/U is including in base contract
Total	\$ 44,815,182	
- Bonus	\$ 1,240,000	Possible Bonus per Performance Requirements
Total w/Bonus	\$ 46,055,182	

ADD "Exhibit 1" as a prefix to the page x of y in the footer.

Specific modifications.

1) Milestone dates:

- a) The start date for the Project has been moved to Monday June 2, 2014.
- b) Section #1 – from the Colchester Tie in to the Williston Gate Station must be ready for gas on or before Friday November 7, 2014. Completion of this section of the pipeline by this date will qualify Over and Under for the schedule bonus for Section #1.
- c) Section #2 and #3 must be complete and ready for gas on or before Monday 7/15/2015.

2) Construction

- a) Over and Under will supply adequate forces with Operator Qualifications to meet the needs of the Project Schedule.
- b) Unloading of pipe delivered to either the Williston or New Haven lay down areas is specifically excluded from this Work.
- c) Loading of pipe material from the lay down yards onto the stringing trucks is specifically included with this Work.
- d) Loading and transport of the ARO piping from the rail yard in Swanton to the specified HDD location is specifically included with this work.
- e) The installation of Cathodic Protection and A/C mitigation using Ark Engineering as a sub-contractor to Over and Under is specifically included with this scope of work.
- f) The installation of cathodic protection and A/C mitigation at the M&R stations utilizing Ark Engineering as a sub-contractor to Over and Under is specifically included with this scope of work.
- g) The supply of Cathodic Protection and A/C mitigation materials is specifically excluded from this scope of work.
- h) Over and Under shall make best efforts to prevent welded pipe joints from being located under road surfaces. Prior to installing any pipe under road surfaces, Over and Under shall review the weld locations with VGS. If a welded joint must be located under the road surface, alternative protection, field applied grout or other substance approved by the engineer, may be required. Alternative protective coating shall be field cured and rapid set to prevent delay to Over and Under.
- i) Pipe that is bent from the factory will arrive coated.
- j) Over and Under has elected to not utilize bending mandrels for field bends and is accepting the risk of performing the bends without mandrels. If the field bends are not acceptable and Over and Under has to resort to using bending mandrels to complete the work in accordance with documents, there will be no additional cost to VGS for Over and Under's supply and use of the bending mandrels.

3) Rock Excavation

- a) Over and Under is performing the job as "unclassified" excavation. Unclassified excavation means that Over and Under is responsible for all costs incurred to deal with the rock material.
- b) Removal of un-fractured excess rock material from the ROW is not included within the scope of Over and Under's work.
- c) Over and Under is intending to use a "trencher" to construct the project and avoid blasting of the rock.
- d) Over and Under has included "rock shield" in the trench where rock material is encountered.
- e) Over and Under has the option to grind and screen the tailings from the rock trencher to create backfill material in lieu of using sand bedding. The cost for the grinding will be off-set against the value of sand bedding material.

- f) Twenty thousand (20,000) CY of sand bedding are included in the base bid as an allowance. No additional sand bedding material has been included with the Rock Excavation. An increase or decrease in the quantity of sand bedding utilized will result in either an increase or decrease in the contract price.
- 4) HDD support
- a) Upon the completion of hydro-pressure testing of the drill pipe and prior to the pipe being pulled into the hole, Over and Under shall coordinate with ECI as to whether the test water can remain in the pipe string or if it must be removed prior to pulling in the string. There is no extra cost to the owner if the water must be removed and re-filled to complete the installation of the pipe and perform the post install hydro-pressure test.
- 5) Environmental Work:
- a) Over and Under is responsible for providing On-Site Plan Coordinators for each of the crews as well as one full time Lead OSPC (non-working) to oversee the compliance of the environmental permits on the Project.
- b) Costs for EPSC Specialist (Erosion Prevention and Sediment Control) is specifically excluded from Over and Under's scope of work.
- c) Over and Under is responsible for all matting necessary for the Work, including placing of mats to protect rare plants as may be required.
- d) In areas where Over and Under does not require all mats as shown on the drawings to complete the Work in accordance with all of the permits, Over and Under is not required to install mats to satisfy the intent of the drawings and there is no credit due.
- 6) Miscellaneous Items:
- a) Over and Under agree to comply with the revised Vermont Gas Systems drug testing program and join the TNT Drug Consortium.
- b) Lien Waivers. Over and Under will provide monthly lien waivers for all sub-contractors and vendors whose contract value, including change orders, is in excess of \$50,000.
- c) Over and Under is responsible for all sales tax, including local sales tax, which are in effect at the time of this contract.
- d) Retainage shall be 10% until the project is 50% billed, at which time no additional retainage will be held, resulting in a total of 5% retainage held at the conclusion of the Work.
- e) Substantial completion is specifically defined as the time when the pipeline has been cleaned and dried and is ready for gas to flow.
- f) Over and Under will bill on a bi-weekly basis utilizing a schedule of values and form agreed to with VGS.
- 7) Bonus Payment
- a) Vermont Gas and Over and Under have developed a bonus structure to reward Over and Under for outstanding performance on the Project. The bonus reflects both companies desire to build the project safely, while complying with VGS' drug program, complying with the permits and in the time frame that fits Vermont Gas' desire to serve Vergennes and Middlebury with gas service for the winter season of 2015. To that end the following bonus structure is agreed to:
- i) Project Section 1 – from the Colchester Tie-in to the Williston M&R Station – Total value of bonus for section 1 is Five Hundred Twenty Thousand (\$520,000) dollars.
- (1) Schedule – ready to gas up on or before November 1, 2014 - Bonus = \$208,000.

- (2) Safety
- (a) No lost time incidents – 100% of bonus = \$104,000
 - (b) One lost time incident – 90% of bonus = \$93,600
 - (c) Two lost time incidents – 80% of bonus = \$83,200
 - (d) More than two lost time incidents – 0% of bonus = \$0
- (3) Clean Drug Testing – No positive drug tests for employees working on the project. Pre-employment drug screening does not affect Over and Under’s ability to earn this portion of the bonus.
- (a) No drug test failures – 100% of bonus = \$104,000
 - (b) One drug test failure – 0% of bonus = \$0.
- (4) Compliance and Quality - No permit infractions that result in monetary fines or stoppage of the Work – Bonus = \$52,000 dollars.
- (5) Customer Service – No customer complaints that result in “escalation” at the Vermont Department of Public Service – Bonus = \$52,000.
- ii) Project Sections 2 and 3– from the Williston M&R Station to the Middlebury Gate Station – Total value of bonus for section one is Seven Hundred Forty Thousand (\$740,000) dollars.
- (1) Schedule – ready to gas up on or before July 15, 2015 results in a graduated bonus schedule. For each week earlier than July 15, 2015, Over and Under will be entitled to a bonus of Fifty Thousand (\$50,000) dollars per week up to a total bonus of Two Hundred Thousand (\$200,000) dollars for early completion. The bonus schedule per week is as follows:
- (a) Ready to gas up after July 9, but before July 15, 2015 – Bonus = \$50,000.
 - (b) Ready to gas up after July 2, but before July 8, 2015 – Bonus = \$100,000.
 - (c) Ready to gas up after June 25, but before July 1, 2015 – Bonus = \$150,000.
 - (d) Ready to gas up prior to June 24, 2015 – Bonus = \$200,000.
- (2) Safety
- (a) No lost time incidents – 100% of bonus = \$190,000
 - (b) One lost time incident – 90% of bonus = \$171,000
 - (c) Two lost time incidents – 80% of bonus = \$152,000
 - (d) More than two lost time incidents – 0% of bonus = \$0
- (3) Clean Drug Testing – No positive drug tests for employees working on the project. Pre-employment drug screening does not affect Over and Under’s ability to earn this portion of the bonus.
- (a) No drug test failures – 100% of bonus = \$190,000
 - (b) One drug test failure – 0% of bonus = \$0.
- (4) Compliance and Quality - No permit infractions that result in monetary fines or stoppage of the Work – Bonus = \$80,000 dollars.
- (5) Customer Service – No customer complaints that result in “escalation” at the Vermont Department of Public Service – Bonus = \$80,000.

CONSTRUCTION PERFORMANCE BOND

Any singular reference to Contractor, Surety, Owner, or other party shall be considered plural where applicable.

CONTRACTOR (Name and Address)

SURETY (Name and Principal Place of Business):

OWNER (Name and Address)
Vermont Gas Systems, Inc.
85 Swift Street
South Burlington, VT 05403

CONSTRUCTION CONTRACT

Date: _____ Amount: _____

Description (Name and Location):

Addison Natural Gas Project – Transmission Main Contract

BOND

Date (not earlier than Construction Contract Date): _____ Amount: _____

Modifications to this Bond Form:

CONTRACTOR AS PRINCIPAL
Company (Corp Seal)

SURETY
Company (Corp Seal)

Signature: _____

Signature: _____

Name and Title:

Name and Title:

CONTRACTOR AS PRINCIPAL
Company (Corp Seal)

SURETY
Company (Corp Seal)

Signature: _____

Signature: _____

Name and Title:

Name and Title:

Add "Performance Bond" as a prefix to each footer.

1. The Contractor and the Surety, jointly and severally, bind themselves, their heirs, executors, administrators, successors, and assigns to the Owner for the performance of the Construction Contract, which is incorporated herein by reference.
2. If the Contractor performs the Construction Contract, the Surety and the Contractor shall have no obligation under this Bond, except to participate in conferences as provided in Subparagraph 3.1.
3. If there is no Owner Default, the Surety's obligation under this Bond shall arise after:
 - 3.1 The Owner has notified the Contractor and the Surety at its address described in Paragraph 10 below, that the Owner is considering declaring a Contractor Default and has requested and attempted to arrange a conference with the Contractor and the Surety to be held not later than fifteen days after receipt of such notice to discuss methods of performing the Construction Contract. If the Owner and the Contractor and the Surety agree, the Contractor shall be allowed a reasonable time to perform the Construction Contract, but such an agreement shall not waive the Owner's right, if any subsequently to declare a Contractor Default; and
 - 3.2 The Owner has declared a Contractor Default and formally terminated the Contractor's right to complete the contract. Such Contractor Default shall not be declared earlier than twenty days after the Contractor and the Surety have received notice as provided in Subparagraph 3.1; and
 - 3.3 The Owner has agreed to pay the Balance of the Contract Price to the Surety in accordance with the terms of the Construction Contract or to a contractor selected to perform the Construction Contract in accordance with the terms of the contract with the Owner.
4. When the Owner has satisfied the conditions of Paragraph 3, the Surety shall promptly and at the Surety's expense take one of the following actions:
 - 4.1 Arrange for the Contractor, with Consent of the Owner, to perform and complete the Construction Contract; or
 - 4.2 Undertake to perform and complete the Construction Contract itself, through its agents or through independent contractors; or
 - 4.3 Obtain bids or negotiated proposals from qualified contractors acceptable to the Owner for Contract or performance and completion of the Construction Contract, arrange for a contract to be prepared for execution by the Owner and the Contractor selected with the Owners's concurrence, to be secured with performance and payment bonds executed by qualified surety equivalent to the bonds issued on the Construction Contract, and pay to the Owner the amount of damages as described in Paragraph 6 in excess of the Balance of the Contract Price incurred by the Owner resulting from the Contractor's default; or
 - 4.4 Waive its right to perform and complete, arrange for completion, or obtain a new contractor and with reasonable promptness under the circumstances:
 1. After investigation, determine the amount for which it may be liable to the Owner and, as soon as practicable after the amount is determined, tender payment therefore to the Owner; or
 2. Deny liability in whole or in part and notify the Owner citing reasons therefor.
5. If the Surety does not proceed as provided in Paragraph 4 with reasonable promptness, the Surety shall be deemed to be in default on this bond fifteen days after receipt of an additional written notice from the Owner to the Surety demanding that the Surety perform its obligations under this Bond, and the Owner shall be entitled to enforce any remedy available to the Owner. If the Surety proceeds as provided in Subparagraph 4.4, and the Owner refuses the payment tendered or the Surety has denied liability, in whole or in part, without further notice the Owner shall be entitled to enforce any remedy available to the Owner.
6. After the Owner has terminated the Contractor's right to complete the Construction Contract, and if the Surety elects to act under Subparagraph 4.1, 4.2, or 4.3 above, then the responsibilities of the Surety to the Owner shall not be greater than those of the Contractor under the Construction Contract, and the responsibilities of the Owner to the Surety shall not be greater than those of the Owner under the Construction Contract. To the limit of the amount of this Bond, but subject to commitment by the Owner of the Balance of the Contract Price to mitigation of costs and damages on the Construction Contract, the Surety is obligated without duplication for:
 - 6.1 The responsibilities of the Contractor for correction of defective work and completion of the Construction Contract;
 - 6.2 Additional legal, design professional and delay costs resulting from the Contractor's Default, and resulting from the actions or failure to act of the Surety under Paragraph 4; and
 - 6.3 Liquidated damages, or if no liquidated damages are specified in the Construction Contract, actual damages caused by delayed performance or non-performance of the Contractor.
7. The Surety shall not be liable to the Owner or others for obligations of the Contractor that are unrelated to the Construction Contract, and the Balance of the Contract Price shall not be reduced or set off on account of any such unrelated obligations. No right of action shall accrue on this Bond to any person or entity other than the Owner or its heirs, executors, administrators, or successors.
8. The Surety hereby waives notice of any change, include changes of time to the Construction Contract or to related subcontracts, purchase orders and other obligations.
9. Any proceeding, legal, or equitable, under this Bond may be instituted in any court of competent jurisdiction in the location in which the work or part of the work is located and shall be instituted within two years after Contractor Default or within two years after the Contractor ceased working or within two years after the Surety refuses or fails to perform its obligations under this Bond, whichever occurs first. If the provisions of this Paragraph are void or prohibited by the law, the minimum period of limitation available to sureties as a defense in the jurisdiction of the suit shall be applicable.
10. Notice to the Surety, the Owner or the Contractor shall be mailed or delivered to the address shown on the signature page.
11. When this bond has been furnished to comply with a statutory or other legal requirements in the location where the construction was to be performed, any provision in this Bond conflicting with said statutory or legal requirements shall be deemed deleted herefrom and provisions conforming to such statutory or other legal requirements shall be deemed incorporated herein. The intent is that this Bond shall be construed as a statutory bond and not as a common law bond.
12. Definitions.
 - 12.1 Balance of the Contract Price: The total amount payable by the Owner to the Contractor under the Construction Contract after all proper adjustments have been made, including allowance to the Contractor of any amount received or to be received by the Owner in settlement of insurance or other claims for damages to which the Contractor is entitled, reduce by all valid and proper payments made to or on behalf of the Contractor under the Construction Contract.
 - 12.2 Construction Contract: The agreement between the Owner and the Contractor identified on the signature page, including all Contract Documents and changes thereto.
 - 12.3 Contractor Default: Failure of the Contractor, which has neither been remedied nor waived, to perform or otherwise to comply with the terms of the Construction Contract.
 - 12.4 Owner Default: Failure of the Owner, which as neither been remedied nor waived, to pay the Contractor as required by the Construction Contract or to perform and complete or comply with other terms thereof.

CONSTRUCTION PAYMENT BOND

Any singular reference to Contractor, Surety, Owner, or other party shall be considered plural where applicable.

CONTRACTOR (Name and Address)

SURETY (Name and Principal Place of Business):

OWNER (Name and Address)

Vermont Gas Systems, Inc.
85 Swift Street
South Burlington, VT 05403

CONSTRUCTION CONTRACT

Date: _____ Amount: _____

Description (Name and Location): Addison Natural Gas Project – Transmission Main Contract

BOND

Date (not earlier than Construction
Contract Date):

_____ Amount: _____

Modifications to this Bond Form:

CONTRACTOR AS PRINCIPAL
Company
(Corp Seal)

SURETY
Company
(Corp Seal)

Signature: _____

Signature: _____

Name and Title:

Name and Title:

CONTRACTOR AS PRINCIPAL
Company
(Corp Seal)

SURETY
Company
(Corp Seal)

Signature: _____

Signature: _____

Name and Title:

Name and Title:

Add "Payment Bond" to the footer of each page.

EJCDC No. 1910-28B (1984 Edition)

Prepared through the joint efforts of The Surety Association of America, Engineers' Joint Contract Documents Committee, The Associated General Contractors of America, and the American Institute of Architects.

1. The Contractor and the Surety, jointly and severally, bind themselves, their heirs, executors, administrators, successors, and assigns to the Owner to pay for labor, materials, and equipment furnished for use in the performance of the Construction Contract, which is incorporated herein by reference.
2. With respect to the Owner, this obligation shall be null and void if the Contractor:
 - 2.1 Promptly makes payment, directly or indirectly, for all sums due Claimants, and
 - 2.2 Defends, indemnifies and hold harmless the Owner from all claims, demands, liens or suits by any person or entity who furnished labor, materials, or equipment for use in the performance of the Construction Contract, provided the Owner has promptly notified the Contractor and the Surety (at the address described in Paragraph 12) of any claims, demands, liens or suits and tendered defense of such claims, demands liens or suits to the Contractor and the Surety, and provided there is not Owner Default.
3. With respect to Claimants, this obligation shall be null and void if the Contractor promptly makes payment, directly or indirectly, for all sums due.
4. The Surety shall have no obligation to Claimants under this Bond until:
 - 4.1 Claimants who are employed by or have a direct contract with the Contractor have given notice to the Surety (at the address described in Paragraph 12) and sent a copy, or notice thereof, to the Owner, stating that a claim is being made under this Bond and, with substantial accuracy, the amount of the claim.
 - 4.2 Claimants who do not have a direct contract with the Contractor:
 1. Have furnished written notice to the Contractor and sent a copy, or notice thereof, to the Owner, within 90 days after having last performed labor or last furnished materials or equipment included in the claim stating, with substantial accuracy, the amount of the claim and the name of the party to whom the materials were furnished or supplied or for whom the labor was done or performed; and
 2. Have either received a rejection in whole or in part from the Contractor, or not received within 30 days of furnishing the above notice any communication from the Contractor by which the Contractor has indicated the claim will be paid directly or indirectly; and
 3. Not having been paid within the above 30 days, have sent a written notice to the Surety (at the address described in Paragraph 12) and sent a copy, or notice thereof, to the Owner stating that a claim is being made under this Bond and enclosing a copy of the previous written notice furnished to the Contractor.
5. If a notice required by Paragraph 4 is given to the Contractor to the Surety, that is sufficient compliance.
6. When the Claimant has satisfied the conditions of Paragraph 4, the Surety shall promptly and at the Surety's expense take the following actions:
 - 6.1 Send an answer to the Claimant, with a copy to the Owner, within 45 days after receipt of the claim, stating the amounts that are undisputed and the basis for challenging any amounts that are disputed.
 - 6.2 Pay or arrange for payment of any undisputed amounts.
7. The Surety's total obligation shall not exceed the amount of this Bond, and the amount of this Bond shall be credited for any payments made in good faith by the Surety.
8. Amount owed by the Owner to the Contractor under the Construction Contract shall be used for the performance of the Construction Contract and to satisfy claims, if any, under any Construction Performance Bond. By the Contractor furnishing and the Owner accepting this Bond, they agree that all funds earned by the Contractor in the performance of the Construction Contract area dedicated to satisfy obligations of the Contractor and the Surety under this Bond, subject to the Owner's priority to use the funds for the completion of the work.
9. The Surety shall not be liable to the Owner, Claimants, or others for obligations of the Contractor that are unrelated to the Construction Contract. The Owner shall not be liable for payment of any costs or expenses of any claimant under this Bond, and shall have under this Bond no obligations to make payments to give notices on behalf of, or otherwise have obligations to make payments to, give notices on behalf of, or otherwise have obligations to Claimants under this Bond.
10. The Surety hereby waives notice of any change, including changes of time, to the Construction Contract or to related subcontracts, purchase orders and other obligations.
11. No suit or action shall be commenced by a Claimant under this Bond other than in a court of competent jurisdiction in the location in which the work or part of the work is located or after the expiration of one year from the date (1) on which the Claimant gave the notice required by Subparagraph 4.1 or Clause 4.2 (iii), or (2) on which the last labor or service was performed by anyone or the last materials or equipment were furnished by anyone under the Construction Contract, whichever of (1) or (2) first occurs. If the provisions of this Paragraph

(FOR INFORMATION ONLY - Name, Address and Telephone)
 AGENT or BROKER: OWNER'S REPRESENTATIVE (Architect, Engineer or other party):

are void or prohibited by law, the minimum period of limitation available to sureties as a defense in the jurisdiction of the suit shall be applicable.

12. Notice to the Surety, the Owner or the Contractor shall be mailed or delivered to the address shown on the signature page. Actual receipt of notice by Surety, the Owner, or the Contractor, however accomplished, shall be sufficient compliance as of the date received at the address shown on the signature page.
13. When this bond has been furnished to comply with a statutory or other legal requirements in the location where the construction was to be performed, any provision in this Bond conflicting with said statutory or legal requirements shall be deemed deleted herefrom and provisions conforming to such statutory or other legal requirements shall be deemed incorporated herein. The intent is that this Bond shall be construed as a statutory bond and not as a common law bond.
14. Upon request by any person or entity appearing to be a potential beneficiary of this Bond, the Contractor shall promptly furnish a copy of this Bond or shall permit a copy to be made.
15. Definitions.
 - 15.1 Claimant: An individual or entity have a direct contract with the Contractor or with a subcontractor of the Contractor to furnish labor, materials, or equipment for use in the performance of the Contract. The intent of this Bond shall be to include without limitation in the terms "labor, materials, or equipment" that part of water, gas, power, light, heat, oil, gasoline, telephone service or rental equipment used in the Construction, architectural and engineering services required for performance of the work of the Contractor and the Contractor's subcontractors, and all other items for which a mechanic's lien may be asserted in the jurisdiction where the labor, materials, or equipment were furnished.
 - 15.2 Construction Contract: The agreement between the Owner and the Contractor identified on the signature page, including all Contract Documents and changes thereto.
 - 15.3 Owner Default: Failure of the Owner, which as neither been remedied nor waived, to pay the Contractor as required by the Construction Contract or to perform and complete or comply with other terms thereof.

SUPPLEMENTARY CONDITIONS

These Supplementary Conditions amend or supplement the Standard General Conditions of the Construction Contract and other provisions of the Contract Documents as indicated below. All provisions which are not so amended or supplemented remain in full force and effect.

SC-1 - DEFINITIONS

The term used in these Supplementary Conditions which are defined in the Standard General Conditions of the Construction Contract have the meanings assigned to them in the General Conditions.

SC-1.18

ENGINEER's CONSULTANT - the following list of independent professional associates and consultants are considered the ENGINEER's CONSULTANT for this Construction Contract:

Vanasse Hangen Brustlin, Inc. (VHB)
-ARK Engineering and Technical Services, Inc.
-Northern Energy Consulting, LLC

SC-1.27

Add the following sentence:

The definitions of "Owner" shall be synonymous with the terms "Vermont Gas Systems, Inc.", "VGS", "Company", and "Buyer", where applicable.

ARTICLE 2 - PRELIMINARY MATTERS

SC-2.2 Copies of Documents.

Amend paragraph 2.2 of the General Conditions to read as follows:

OWNER shall furnish to CONTRACTOR one hard copy and an electronic version in pdf format of the Contract Documents.

And as so amended paragraph 2.2 remains in effect.

SC-2.3

Amend the third sentence of paragraph 2.3 of the General Conditions to read as follows:

In no event will the Contract Times commence to run later than the thirtieth day after the Effective Date of the Agreement.

And as so amended paragraph 2.3 remains in effect.

SC-2.6.4 The following VGS Specific Documents and requirements have been provided to the CONTRACTOR and are part of the Contract Documents and Agreement between the OWNER and CONTRACTOR.

2.6.4.1 Operator Qualification Plan, OQ certificates and Task lists (OQ)

2.6.4.2 CONTRACTOR shall comply with the revised Vermont Gas Systems drug testing program and join the TNT Drug Consortium as detailed in Exhibit 1.

SC-2.7

Amend the first sentence of paragraph 2.7 of the General Conditions to read as follows:

Before any work at the site is started, CONTRACTOR shall deliver to OWNER with copies to each additional insured identified in the Supplementary Conditions, Certificates of Insurance (and other evidence of insurance which OWNER or any other additional insured may reasonably request) which CONTRACTOR is required to purchase and maintain in accordance with Article 5 as amended by these Supplementary Conditions.

And as so amended paragraph 2.7 remains in effect.

SC-2.8

Amend the first segment of the first sentence of paragraph 2.8 of the General Conditions to read as follows:

Within 20 days after the Contract Times commence to run, but before any work at the site is started,...

And as so amended paragraph 2.8 remains in effect.

ARTICLE 3 – CONTRACT DOCUMENTS: INTENT, AMENDING, REUSE

SC-3.3.3

Replace with the following:

Except as otherwise specifically stated in the Contract Documents or as may be provided by amendment or supplement thereto issued by one of the methods indicated in paragraph 3.5 or 3.6, the following documents, listed in order of highest to lowest

importance, shall take precedence in resolving any conflict, error, ambiguity, or discrepancy within the Project Manual or Project Plans:

- Vermont Gas Systems, Inc. – Operations and Maintenance Manual Abridged Version for Transmission Construction Contractors - 2013
- Vermont Gas ANGP Project Scope of Work and Specifications
- All other Technical Specifications
- Project Plans and Drawings

ARTICLE 4 - AVAILABILITY OF LANDS;
SUBSURFACE AND PHYSICAL CONDITIONS;
REFERENCE POINTS

SC-4.2.1.

Amend the first sentence of paragraph 4.2.1 of the General Conditions to read as follows:

Reports and Drawings: Reference is made to the 'Information Available to Bidders' for identification of:

And as so amended paragraph 4.2.1 remains in effect.

SC-4.2.2

Amend the second sentence of paragraph 4.2.2 of the General Conditions to read as follows:

Such "technical data" is identified in the Information Available to Bidders.

And as so amended paragraph 4.2.2 remains in effect.

SC-4.3.1

Amend the second sentence of paragraph 4.3.1 of the General Conditions to read as follows:

Unless it is otherwise expressly provided in the "Information Available to Bidders:"

And as so amended paragraph 4.3.1 remains in effect.

SC-4.4

Amend the second sentence of paragraph 4.4 of the General Conditions to read as follows:

ENGINEER shall be responsible for laying out the Work, including pipe centerline, edges of permanent and temporary easements/right-of-ways, edge of access roads, additional temporary work spaces (ATWS), pipeyards, meter & regulation stations, and the tie-in station.

Contractor shall be responsible for protecting, preserving and maintaining the established reference points and shall make no changes or relocations without the prior written approval of OWNER and ENGINEER, CONTRACTOR shall report to CONSTRUCTION MANAGER whenever any reference point is lost or destroyed or requires relocation because of necessary changes in grades or locations, and shall be responsible for the accurate replacement or relocation of such reference points by a Vermont licensed professional land surveyor.

ARTICLE 5 - BONDS AND INSURANCE

New Bond and Insurance Provisions:

SC-5

Article 5 of the General Conditions is hereby deleted in its entirety and replaced with the following provisions.

Performance and Payment Bonds:

SC 5.1

CONTRACTOR shall furnish Performance and Payment Bonds, each in an amount of at least equal to the Contract Price as security for the faithful performance and payment of all CONTRACTOR's obligations under the Contract Documents. These Bonds shall remain in effect, at a minimum, for one year after the date when the final payment becomes due, except as provided otherwise by Laws or Regulations or by the Contract Documents.

SC 5.1.1

All Bonds shall be in the form prescribed by the Contract Documents except as provided otherwise by Laws or Regulations, and shall be executed by such sureties as are named in the current list of "Companies Holding Certificates of Authority as Acceptable Sureties on Federal Bonds and as Acceptable Reinsuring Companies" as published in Circular 570 (as amended) by the U.S. Treasury Department. All Bonds signed by an agent must be accompanied by a certified copy of such agent's authority to act.

SC 5.2

If the surety on any Bond furnished by CONTRACTOR files a petition in bankruptcy, becomes insolvent, is reasonably likely to become insolvent in the near future, or its right to do business is terminated in any state where any part of the Project is located, or it ceases to meet the requirements of paragraph 5.6, CONTRACTOR shall within ten days thereafter substitute another bond and surety, both of which must be acceptable to OWNER

Licensed Sureties and Insurers:

SC 5.3

All insurance required by the Contract Documents to be purchased and maintained by OWNER or CONTRACTOR shall be obtained from surety or insurance companies that are duly licensed or authorized in the jurisdiction in which the Project is located to issue Bond or insurance policies for the limits and coverages required. Such surety and insurance companies shall also meet such additional requirements and qualifications as may be provided in these Supplementary Conditions.

CONTRACTOR'S Liability Insurance:

SC 5.4

CONTRACTOR shall, at his own cost and expense, take out and maintain for the life of the Project and cause his Subcontractors to obtain and maintain for the life of their subcontracts, the following insurance:

Commercial General Liability Insurance:

SC 5.4.1

Commercial General Liability (CGL) with limits of insurance of not less than:

Limits of Liability:

\$10,000,000	Each Occurrence
\$10,000,000	General Aggregate Limit (Per Project – CG 25 0311/85)
\$10,000,000	Products/Completed Operations
\$10,000,000	Advertising/Personal Injury
\$ 10,000	Premises Medical Payments

CONTRACTOR's CGL policy shall also include, without limitation, the following coverages: Products/Completed Operations, Contractual Liability and Explosion, Collapse and Underground Damage.

OWNER, DESIGN ENGINEER, CONSTRUCTION MANAGER, and ENGINEER shall be included as insureds on the CONTRACTOR's CGL, using ISO Additional Insured Endorsement CG 20 10 11 85 or an endorsement providing equivalent coverage to the additional insureds. The CGL insurance for the additional insureds shall be as broad as the coverage provided for the named insured CONTRACTOR. It shall apply as primary and non-contributing insurance before any insurance maintained by the additional insureds.

CONTRACTOR shall maintain CGL coverage for itself and all additional insureds for the duration of the project

and maintain Completed Operations coverage for itself and all additional insureds for at least 3 years after completion of the work.

Automobile Liability Insurance:

SC 5.4.2

Business Automobile Liability (AL) with limits of insurance of not less than \$1,000,000, Combined Single Limit. AL coverage must include coverage for liability arising out of all owned, leased, hired and non-owned automobiles.

OWNER, CONSTRUCTION MANAGER and ENGINEER shall be included as additional insureds on the CONTRACTOR's AL policy. The AL coverage for the additional insured shall apply as primary and non-contributing insurance payable before any insurance maintained by the additional insureds.

Workers' Compensation and Employer's Liability Insurance:

SC 5.4.3

Workers Compensation (WC) as required by statute in Vermont and in the state where the Contractor is domiciled, whichever is greatest.

Employer's Liability (EL) with limits of insurance of not less than \$500,000 each accident for bodily injury by accident and \$500,000 each employee for injury by disease.

The policy shall include an All States coverage endorsement. Where applicable, the U.S. Longshore and Harbor workers Compensation Act Endorsement shall be attached to the policy. Where applicable, the Maritime Coverage Endorsement shall be attached to the policy. Where applicable, the Stop Gap Endorsement shall be attached to the policy.

Commercial Umbrella Liability Insurance:

SC 5.4.4

Commercial Umbrella Liability (UL) with limits of insurance of not less than \$25,000,000.

Pollution Liability Coverage:

SC 5.4.6

Pollution Legal Liability (PLL) with limits of Insurance of not less than \$10,000,000 each occurrence and \$25,000,000 annual aggregate. The maximum deductible shall not

exceed \$25,000 and shall be assumed by, for the account of, and at the sole risk of the Contractor.

CONTRACTOR's PLL policy shall include coverage for damage to soil, surface water or plant or animal caused by the discharge, dispersal, release or escape of any solid, liquid, gaseous or thermal irritant or contaminant, including smoke, vapors, soot, fumes, acids, alkalis, toxic chemicals, medical waste and waste materials into or upon land, or any structure on land, the atmosphere or any watercourse or body of water, including groundwater.

OWNER, DESIGN ENGINEER, CONSTRUCTION MANAGER, and ENGINEER shall be included as insureds on the CONTRACTOR'S PLL, using ISO Additional Insured Endorsement CG 20 10 11 85 or an endorsement providing equivalent coverage to the additional insureds. The PLL insurance for the additional insureds shall be as broad as the coverage provided for the named insured CONTRACTOR. It shall apply as primary and non-contributing insurance before any insurance maintained by the additional insureds.

Waiver of Subrogation:

SC 5.5

CONTRACTOR waives all rights against OWNER, DESIGN ENGINEER, CONSTRUCTION MANAGER, and ENGINEER and their agents, officers, directors and employees for recovery of damages to the extent these damages are covered by the CGL, PLL, BR, UL, AL or WC and EL insurance maintained per the requirements set forth above.

Required Insurance Carriers:

SC 5.6

All of the above insurance requirements shall be provided by an insurance carrier licensed to business in the state where the Project is located and have an A.M. Best Rating of A- or better as determined by the most recent A.M. Best Publication.

Certificates of Insurance:

SC 5.7

Within five business days of the Contract being executed, CONTRACTOR shall deliver to OWNER, with copies to each additional insured identified in the Supplementary Conditions, Certificates of Insurance (and other evidence of insurance reasonably requested by the OWNER or any other additional insured) which CONTRACTOR is required to purchase and maintain in accordance with the Contract Documents. OWNER shall deliver to

CONTRACTOR, with copies to each additional insured identified in the Supplementary Conditions, Certificates of Insurance (and other evidence of insurance reasonably requested by the CONTRACTOR or any other additional insured) which OWNER is required to purchase and maintain in accordance with the Contract Documents.

SC 5.7.1

Each Certificate of Insurance shall be endorsed to provide for 30 days notice of cancellation, non-renewal or material change to the Certificate Holder and each additional insured except where Laws or Regulations require otherwise. The endorsement shall read: "No cancellation of or change in this policy shall become effective until after thirty (30) days notice by issuing company."

Effect of Insurance Coverage; Claims in Excess of Coverage:

SC 5.8

Upon failure of the CONTRACTOR to furnish, deliver and maintain such insurance as required above, this Contract may, at the election of the OWNER, be forthwith declared suspended, discontinued or terminated. Failure of the CONTRACTOR to take out or maintain or the taking out or maintenance of any required insurance, shall not relieve the CONTRACTOR's liability under the Contract nor shall the insurance requirements be construed to limit the obligations of indemnification or contribution.

SC 5.8.1

In the event that claims in excess of the amounts provided by insurance are filed by reason of any operations under the Contract, the amount of excess of such claims, or any portion thereof, may be withheld from payment due to or become due the CONTRACTOR until such time as the CONTRACTOR shall furnish additional security covering such claims as may be determined by the OWNER.

Waiver of Rights:

SC 5.9

OWNER and CONTRACTOR intend that policy purchased and maintained pursuant to paragraphs 5.4.5 will protect OWNER, CONTRACTOR, SUBCONTRACTORS, ENGINEER, ENGINEER'S CONSULTANTS and all other persons or entities identified in these Supplementary Conditions to be listed as insureds or additional insureds in such policies and will provide primary coverage for all losses and damages caused by the perils covered thereby. Each policy required by the CONTRACTOR shall contain provisions to the effect that in the event of payment of any loss or damage the insurers will have no rights of recovery

against any of the insureds or additional insureds thereunder.

Receipt and Application of Insurance Proceeds:

SC 5.10

Any insureds' loss under any policy of insurance required by these Supplementary Conditions will be adjusted with OWNER and made payable to OWNER. OWNER shall deposit in a separate account any money so received and shall distribute it in accordance with such agreement as the parties in interest may reach. If no other special agreement is reached, damaged Work shall be repaired or replaced, the moneys so received for damaged Work applied on account thereof and the Work and the cost thereof will be covered by an appropriate Change Order or written Amendment.

SC 5.10.1

OWNER shall have the power to adjust and settle any loss with the insurers unless one of the parties in interest shall object in writing within fifteen days after the occurrence of loss to OWNER's exercise of this power. If such objection be made, OWNER shall make settlement with the insurers in accordance with such agreement as the parties in interest may reach. If no such agreement among the parties in interest is reached, OWNER shall adjust and settle the loss with the insurers.

Disability Benefits:

SC 5.11

Where and as required by law, CONTRACTOR will provide disability benefits during the duration of the Contract for the employees required to be covered.

Acceptance of Bonds and Insurance; Option to Replace:

SC 5.12

If either party (OWNER or CONTRACTOR) has any objection to the coverage afforded by or other provisions of the Bonds or insurance required to be purchased and maintained by the other party in accordance with Article 5 on the basis of non-conformance with the Contract Documents, the objecting party shall so notify the other party in writing within ten days after receipt of the certificates (or other evidence requested) required by paragraph 2.7. OWNER and CONTRACTOR shall each provide to the other such additional information in respect of insurance provided as the other may reasonably request.

If either party does not purchase or maintain all of the Bonds and insurance required of such party by the Contract Documents, such party shall notify the other party in

writing of such failure to purchase prior to the start of the Work, or of such failure to maintain prior to any change in the required coverage. Without prejudice to any other right or remedy, the other party may elect to obtain equivalent Bonds or insurance to protect such other party's interests at the expense of the party who was required to provide such coverage, and a Change Order shall be issued to adjust the Contract Price accordingly.

Partial Utilization – Property Insurance:

SC 5.13

If OWNER finds it necessary to occupy or use a portion or portions of the Work prior to Substantial Completion of all the Work, such use or occupancy may be accomplished in accordance with paragraph 14.10; provided that no such use or occupancy shall commence before the insurers providing the property insurance have acknowledged notice thereof and in writing effected any changes in coverage necessitated thereby. The insurers providing the property insurance shall consent by endorsement on the policy or policies, but the property insurance shall not be canceled or permitted to lapse on account of any such partial use or occupancy.

SC 5.14

The foregoing insurance coverage shall be primary and non-contributing with respect to any other insurance or self-insurance which may be maintained by the OWNER. Contractor's Comprehensive General Liability and Automobile Liability Insurance policies shall contain a Cross-Liability or Severability of interest clause.

ARTICLE 6 - CONTRACTOR'S RESPONSIBILITY

SC-6.2.1

Add a new paragraph immediately after paragraph 6.2 of the General Conditions which reads as follows:

Contractor shall observe recognized safety standards, such as those of the National Fire Protection Association and the American National Standards Institute, ensure safety on the site, through safe work practices and an effective safety management program, maintain safe equipment and material storage and employ good site housekeeping and fire prevention practices, establish a safe traffic flow for pedestrians and vehicles and employ measures to prevent falling or collapsing items in their vicinity, and require that contractors make their subcontractors follow the same safe work practices.

SC-6.7

SC-6.3

SC-6.3 shall be replaced with the following paragraph:

CONTRACTOR shall provide competent, suitably qualified personnel to construct the Work as required by the Contract Documents. CONTRACTOR shall at all times maintain good discipline and order at the site. Except as otherwise required for the safety or protection of persons or the Work or property at the site or adjacent thereto, and except as otherwise indicated in the Contract Documents, all Work at the site shall be performed during the hours defined in the regulatory permits/documents without OWNER'S written consent given after prior written notice to ENGINEER.

Add the following language at the end of the first sentence of paragraph 6.7 of the General Conditions:

Whenever the term "or-equal" is followed by the words "requiring prior approval" in the specification or description of an item of material or equipment, the CONTRACTOR's proposed equivalent will be submitted for ENGINEER's approval as described in paragraph 10 in the Instructions to Bidders.

And as so amended paragraph 6.7 remains in effect.

SC-6.8

Add a new paragraph immediately before paragraph 6.8.1 of the General conditions which is to read as follows:

The CONTRACTOR shall submit a list of SUBCONTRACTORS and major Material Suppliers for the OWNER's approval prior to the Notice of Award. Such list shall be accompanied by an experience statement with pertinent information as to similar projects and other evidence of qualifications from each such SUBCONTRACTOR, person and organization requested by OWNER. If OWNER, after due investigation has reasonable objections to any proposed SUBCONTRACTOR, other person or organization, the OWNER may before giving the Notice of Award request the apparent successful BIDDER to submit an acceptable SUBCONTRACTOR without an increase in Bid Price. If the apparent successful BIDDER declines to make any such substitution, the Contract shall not be awarded to such BIDDER, but his declining to make any such substitution will not constitute grounds for sacrificing his Bid Security. Any SUBCONTRACTOR, other person or organization so listed and to whom OWNER does not make written objection prior to the giving of the Notice of Award will be deemed acceptable to OWNER.

And as so amended paragraph 6.8 remains in effect.

SC-6.13 Permits

The OWNER has submitted for an approval from necessary regulatory agencies for the Work. Copies of the applications together with the supporting documents are included in as an attachment to these Supplemental Conditions under separate cover. Copies of the approvals/permits will be made available to the CONTRACTOR and become part of the Contract. CONTRACTOR is required to comply with the conditions of the permits. CONTRACTOR shall bear all responsibilities for any and all regulatory fines, penalties or delays associated with each issued permit.

And as so amended paragraph 6.13 remains in effect.

SC-6.16 Use of Premises

Add the following language at the end of paragraph 6.16 of the General Conditions:

The Work is paralleling an existing gas main within Rights-of-Ways and easements which the OWNER has the necessary easements. A property owners' line list together with conditions is attached hereto. The CONTRACTOR is required to comply with all conditions. Should the CONTRACTOR determine that additional Temporary Construction Easements are necessary based on storage area and support facilities CONTRACTOR shall be responsible for obtaining said easements at CONTRACTOR's expense.

And as so amended paragraph 6.16 remains in effect.

ARTICLE 9 - ENGINEER'S STATUS DURING CONSTRUCTION

SC-9.3

Add thirty-five (35) new paragraphs immediately after the last paragraph in section 9.3 of the General Conditions which are to read as follows:

9.3.1 OWNER will furnish a Construction Manager, assistants and other field staff as needed, to assist ENGINEER in observing performance of the Work. The Construction Manager is to observe and inspect, in the OWNER'S interest, the materials furnished and the work done as the work progresses in order to insure full and complete compliance with the contract and to verify quantities of work completed.

9.3.2 OWNER may also designate one, or several, of its employees to represent OWNER for these purposes.

9.3.3 ENGINEER, Construction Manager, OWNER and all such other persons referred to shall have unrestricted access to all parts of the Work. CONTRACTOR shall cooperate by supplying necessary facilities and assistance required by above persons to carry out their work of observation and inspection.

9.3.4 It is not the function of the ENGINEER, Construction Manager or OWNER to supervise or direct the manner in which the work to be done under this CONTRACT is carried on or conducted. The ENGINEER, Construction Manager or OWNER is not responsible for construction means, methods, techniques, sequences or procedures, or for safety precautions and programs in connection with the work, and they will not be responsible for the CONTRACTOR'S failure to carry out the work in accordance with the Contract Documents. Nevertheless, CONTRACTOR agrees that any method or procedure, which in the opinion of the ENGINEER or OWNER does not achieve the required results or quality of the work specified, shall be discontinued immediately upon the order of the ENGINEER or OWNER.

9.3.5 All communications between CONTRACTOR and ENGINEER or CONTRACTOR and OWNER are to be through the Construction Manager.

9.3.8 The ENGINEER shall have the authority to reject any work, or materials, or any part thereof, which does not in his opinion conform to the plans, drawings, specifications and contract, and it shall be permissible for him to do so at any time during the progress of the work and until its acceptance.

No material of any kind shall be used upon the work until it has been inspected and accepted by the ENGINEER. All materials rejected shall be removed immediately from the work and not again offered for inspection. Any materials or workmanship found at any time to be defective or not of the quality or character required by the plans and specifications shall be remedied at once regardless of previous inspection.

Such inspection shall not relieve the CONTRACTOR from any obligation to perform said work strictly in accordance with the plans and specifications and work not so constructed shall be removed and made good by the CONTRACTOR at his own expense, and free from all expense to the OWNER whenever so ordered by the OWNER without reference to any previous oversight or error in inspection.

SC-9.10

Amend the second sentence of paragraph 9.10 of the General Conditions by striking out the following words:

(i) An appeal from ENGINEER's decision is taken within the time limits and in accordance with the procedures set forth in Exhibit GC-A, "Dispute Resolution Agreement," entered into between OWNER and CONTRACTORS pursuant to Article 16, or (ii) if no such dispute resolution agreement has been entered into.

And as so amended paragraph 9.10 remains in effect.

SC-9.11

Amend the sixth sentence of paragraph 9.11 of the General Conditions by striking out the following words:

(i) an appeal from ENGINEER's decision is taken within the time limits and in accordance with the procedures set forth in Exhibit GC-A "Dispute Resolution Agreement," entered into between OWNER and CONTRACTOR pursuant to Article 16, or (ii) if no dispute resolution agreement has been entered into.

And as so amended paragraph 9.11 remains in effect.

SC-9.12

Amend the second sentence of paragraph 9.12 of the General Conditions by striking out the following words:

Pursuant to Article 16.

And as so amended paragraph 9.12 remains in effect.

ARTICLE 11 – CHANGE OF CONTRACT PRICE

SC-11.4.1

Add the following last sentence to the paragraph:

Davis Bacon Act prevailing wage rates are not applicable to this Project.

ARTICLE 14 - PAYMENT TO CONTRACTOR AND COMPLETION

SC14.2

The first sentence of paragraph 14.2 shall be revised as follows:

“At least five days before the date established for each progress payment, which shall be bi-weekly, CONTRACTOR shall submit to CONSTRUCTION MANAGER for review an Application for Payment filled out and signed by CONTRACTOR covering the work completed as of the date of the Application and accompanied by such supporting documentation as is required by the Contract Documents.”

SC-14.4

Review of Applications for Progress Payment:

Amend the third sentence of paragraph 14.4 by striking out the words:

Ten (10) days after presentation...

and by substituting the following:

Thirty (30) days after presentation...."

And as so amended paragraph 14.4 remains in effect.

SC-14.10

Add a new subparagraph 14.10.3 to paragraph 14.10 of the General Conditions which is to read as follows:

OWNER may at any time request CONTRACTOR in writing to permit OWNER to take over operation of any such part of the Work although it is not substantially complete. A copy of such request will be sent to ENGINEER and within a reasonable time thereafter OWNER, CONTRACTOR, and ENGINEER shall make an inspection of that part of the Work to determine its status of completion and will prepare a list of the items remaining to be completed or corrected thereon before final payment.

If CONTRACTOR does not object in writing to OWNER and ENGINEER that such part of the Work is not ready for separate operation by OWNER, ENGINEER will finalize the list of items to be completed or corrected and will deliver such lists to OWNER and CONTRACTOR together with a written recommendation as to the division of responsibilities pending final payment between OWNER and CONTRACTOR with respect to security, operation, safety, maintenance, utilities, insurance, warranties

and guarantees for that part of the Work which will become binding upon OWNER and CONTRACTOR at the time when OWNER takes over such operation (unless they shall have otherwise agreed in writing and so informed ENGINEER). During such operation and prior to Substantial Completion of such part of the Work, OWNER shall allow CONTRACTOR reasonable access to complete or correct items on said list and to complete other related Work.

ARTICLE 15 - SUSPENSION OF WORK AND TERMINATION

SC-15.2

Add additional subparagraphs to paragraph 15.2 of the General Conditions as follows:

15.2.5 if CONTRACTOR commences a voluntary case under any chapter of the Bankruptcy Code (Title 11, United States Code), as now or hereafter in effect, or if CONTRACTOR takes any equivalent or similar action by filing a petition or otherwise under any other federal or state law in effect at such time relating to the bankruptcy or insolvency;

15.2.6 if a petition is filed against CONTRACTOR under any chapter of the Bankruptcy Code (Title 11, United States Code), as now or hereafter in effect at the time of filing, or if a petition is filed seeking any such equivalent or similar relief against CONTRACTOR under any other federal or state law in effect at the time relating to bankruptcy or insolvency;

15.2.7 if CONTRACTOR makes a general assignment for the benefit of creditors;

15.2.8 if a trustee, receiver, custodian, or agent of CONTRACTOR is appointed under applicable law or under contract, whose appointment or authority to take charge of property of CONTRACTOR is for the purpose of enforcing a Lien against such property or for the purpose of general administration of such property for the benefit of CONTRACTOR'S creditors;

15.2.9 if CONTRACTOR admits in writing an inability to pay its debts generally as they become due.

ARTICLE 16 - DISPUTE RESOLUTION

SC-16

Delete Article 16 of the General Conditions in its entirety and add the following:

OWNER and CONTRACTOR may exercise any and all rights and remedies that are available under Law and Regulations in respect of any dispute concerning rights or obligations under or pursuant to the Contract Documents and with respect to the Work.

ARTICLE 17 - MISCELLANEOUS

SC-17

Amend the first sentence of paragraph 17.5 of the General Conditions by striking out the following words:

Or arbitration.

And as so amended paragraph 17.5 remains in effect.

SC-18 DIRECT CLAIMS

18.1 CONTRACTOR shall make no direct claim against ENGINEER or its consultants for costs or damages arising out of, resulting from or in connection with any alleged act, error or omission by ENGINEER; however, provided that this limitation shall not prohibit the CONTRACTOR from making such claims against the party with whom it has contracted nor prevent such party from making claims against the ENGINEER, except as otherwise limited in their agreements.

SC-19 – CORPORATE IMAGE

19.1 OWNER VGS maintains a respected corporate image and its employees pride themselves on customer service and satisfaction in the office and field. VGS' Contractors represent not only their company but also VGS. It is the responsibility of the Contractor to maintain professional, courteous, caring and safe employees. VGS reserves the right to terminate any contract awarded pursuant to this RFP if the Contractor does not maintain employees with these traits. VGS further reserves the right to remove a Contractor's employee from VGS' jobsite for failure to exhibit those traits and for non-conformance to contract terms and conditions of the Agreement.

ENGINEER'S ADDENDUM NO. 01
TO THE BID DOCUMENTS (PLANS AND SPECIFICATIONS) FOR
Proposed System Expansion
Addison Natural Gas Project (ANGP)
Transmission Contract
October 18, 2013

The following changes and/or additions shall be made to the plans and/or specifications. All other requirements of the contract documents shall remain the same. Acknowledge receipt of this addendum by inserting its number and date in the Bid Proposal.

Changes/Additions to the Bid Documents:

THIS ADDENDUM is hereby made a part of the contract documents on the subject work as though originally included therein. The following amendments, additions and/or corrections shall govern this work.

This Addendum is in the following parts as follows:

- | | |
|----------|--|
| Part I | - Pertaining to Drawings |
| Part II | - Pertaining to Technical Specifications |
| Part III | - Clarifications to Contractor's Questions |
| Part IV | - List of Attachments |
| Part V | - Additional Information |

PART I - PERTAINING TO DRAWINGS

1. ADD the following drawings:
 - a. "Colchester Launcher and Tie-In Site" dated 9/24/13 produced by CHA. The entire scope of the Colchester Launcher and Tie-In Site is now a requirement of the Transmission Contract.
 - b. "Williston M&R Station" dated 9/24/13 produced by CHA. NOTE: Only information applicable to installation of the access road (outside of the M&R fenced area) is applicable.
 - c. "Plank Road M&R Station" dated 9/24/13 produced by CHA. NOTE: Only information applicable to installation of the mainline valve (within the M&R fenced area) and the access road (outside of the M&R fenced area) are applicable.
 - d. "Middlebury M&R Station" dated 9/24/13 produced by CHA. NOTE: Only information applicable to installation of the mainline valve (within the M&R fenced area) and the access road (outside of the M&R fenced area) are applicable.
 - e. "Cathodic Protection System Design – Installation Drawings" dated 9/30/13 produced by ARK Engineering & Technical Services, Inc.
 - f. "AC Mitigation System Design – Valve Site Grounding Installation Drawings" dated 9/30/13 produced by ARK Engineering & Technical Services, Inc.
 - g. "Zinc Ribbon Installation Drawings" dated 10/10/13 produced by ARK Engineering & Technical Services, Inc.
2. REPLACE the following sheets with the attached sheets:
 - a. ANGP-T-G-011 (EPSC Plans Only)
 - b. ANGP-T-G-013 (EPSC AND Alignment Plans)
 - c. ANGP-T-G-015 (EPSC AND Alignment Plans)

PART II - PERTAINING TO TECHNICAL SPECIFICATIONS

1. Table of Contents: REPLACE with the attached REVISED Table of Contents.
2. Invitation to Bid
 - a. Sixth paragraph, last sentence shall be REPLACED with the following: "This bid shall remain valid for a period of *sixty (60)* days from the bid due date."
3. Instruction to Bidders
 - a. Item 14 – REPLACE "forty-five (45)" with "sixty (60)".
 - b. Item 15.6 – REPLACE "forty-five (45)" with "sixty (60)".
 - c. Item 21.1 – REPLACE the second sentence with the following: "All Contractors must be qualified under the NGA Operator Qualification Plan."
4. Information Available to Bidders
 - a. ADD the following as item #2 under "Other Data": "2. Tables for Jack/Bore Locations, Horizontal Directional Drill (HDD) Locations, Stream Crossings and Utility Infrastructure Crossings"
 - b. ADD the following as item #3 under "Other Data": "3. Mainline Valve Location Table"
 - c. ADD the following as item #4 under "Other Data": "4. Project Manual – Vermont Gas Systems Addison Natural Gas Project – Horizontal Directional Drill Design/Build"
5. Agreement
 - a. Section 5.1 – REPLACE the first sentence as follows: "OWNER shall make progress payments on account of the Contract Price on the basis of CONTRACTOR's Applications for Payment as recommended by ENGINEER, on a Net 30 day basis during construction as provided in paragraphs 5.1.1 and 5.1.2 below."
 - b. Section 5.1.2 – DELETE entire second paragraph "If Work has been 50% completed...equal to 90% of the Work completed."
 - c. Section 7.8 – REPLACE the listed drawing sets with the drawings listed on the attached Table of Contents.
6. Bid Form: REPLACE with the attached REVISED Bid Form.
7. Bid Summary Form: REPLACE with the attached REVISED Bid Summary Form.
8. Supplemental Conditions: ADD the following:

SC-14.2

The first sentence of paragraph 14.2 shall be REVISED as follows: "At least ten days before the date established for each progress payment, which shall be **bi-weekly**, CONTRACTOR shall submit to ENGINEER for review an Application for Payment filled out and signed by CONTRACTOR covering the work completed as of the date of the Application and accompanied by such supporting documentation as is required by the Contract Documents."
9. Division VGS – Special Construction (Gas Pipeline)
 - a. Vermont Gas ANGP Project Scope of Work and Specifications Item 13.i. REPLACE with the following: "i. The pipe shall rest on undisturbed trench bottom provided the material does not include rocks, sharp objects and/or debris

that may cause damage to the pipe. Structured pipe pillows shall be installed in the bottom of the trench at maximum intervals of every 16ft to protect the pipe from lying on rocks, sharp objects and/or debris which may cause damage to the pipe or pipeline coating. The COMPANY may require the CONTRACTOR to use select fill trench bottom padding material. ~~Select fill base material for rock trench, shall provide a minimum of twelve (12) inches of padding around the entire circumference of the pipe. Select fill material and/or padding material shall not exceed 1 1/2 inches diameter and shall be placed completely around the pipe.~~ *Select fill base material for rock trench areas and areas with cobbles/boulders, shall provide a minimum of nine (9) inches of padding below and twelve (12) inches of padding on the sides and top of the pipe. Select fill material and/or padding material shall be sand in accordance with VTrans Standard Specification 703.03 or shall be screened native material containing silts, sands and gravels with the largest material being no larger than 1-inch on the longest dimension.* Topsoil from the RIGHT-OF-WAY shall not be used for padding material. ~~All select fill padding shall be procured from existing commercial facilities and shall be of sand.~~

- a. Vermont Gas ANGP Project Scope of Work and Specifications Item 26.w. REPLACE with the following: “w. Pipe installed at specified crossings shall be hydrostatically tested for four hours at a pressure specified by the COMPANY, both prior to, and after installation.”
10. Division 01 – General Requirements
- a. Section 011000 Summary – REPLACE with attached 01100 Summary Specification.
 - b. Section 012300 Alternates – REPLACE the Specification with the attached 012300 Alternates Section

PART III – CLARIFICATIONS TO CONTRACTOR QUESTIONS

1. Answers to questions asked during the Pre-bid meeting have been addressed in the Pre-Bid Meeting Minutes (Refer to Part IV Below).
2. Additional questions for the Transmission Contract have not been asked since the Pre-Bid Meeting as of the date of this Addendum.

PART IV – LIST OF ATTACHMENTS

1. Pre-Bid Meeting Minutes titled “Addison Natural Gas Project Phase 1 – Transmission Pre-Bid Minutes of Meetings.
2. Drawings noted in PART I
3. Project Manual Table of Contents
4. Tables for Jack/Bore Locations, Horizontal Directional Drill (HDD) Locations, Stream Crossings, and Utility Infrastructure Crossings (Information Available for Bidders)
5. Mainline Valve Location Table (Information Available for Bidders)
6. HDD Contract Information – The HDD contract is available at the following location: <https://www.chafiles.com/fs/v.aspx?v=8d6d6a8c60a8a27c6c97> (Information Available for Bidders)

7. HDD Duration Table (Information Available for Bidders)
8. Project Manual Bid Form
9. Project Manual Bid Summary Form
10. Project Manual Specification 011000 Summary
11. Project Manual Specification 012300 Alternates
12. Blasting Plan for Addison Natural Gas Project dated June 25, 2012. (ADD to Supplemental Condition Attachments)
13. Environmental Permits Key Points Slideshow presented by Josh Sky and Krista Reinhart VHB.
14. Pre-Bid Meeting Alignment/Project Overview Slideshow presented by Mike Flock of CHA.
15. Acceptable Management Practices (AMP) for Maintaining Water Quality

PART V – ADDITIONAL INFORMATION

1. If Contractors plan on submitting bids on multiple contracts (two or three) together, a cover letter stating specifics of combining the contracts shall be submitted. The letter, at a minimum, should discuss whether receiving one contract is contingent upon receiving other contracts, cost savings for “bundling” projects, logistics of approaching all three contracts, and other pertinent items for consideration by Vermont Gas Systems. This cover letter shall be attached with each bid package submitted.

END OF ENGINEER'S ADDENDUM

Date: October 18, 2013
Submitted by: CHA

V:\Projects\ANY\K3\25158\Construction\Bid\Addendum No 1\Addendum 1.doc

DRAFT - NOT FOR CONSTRUCTION

ENGINEER'S ADDENDUM NO. 02
TO THE BID DOCUMENTS (PLANS AND SPECIFICATIONS) FOR
Proposed System Expansion
Addison Natural Gas Project (ANGP)
Transmission Contract
October 29, 2013

The following changes and/or additions shall be made to the plans and/or specifications. All other requirements of the contract documents shall remain the same. Acknowledge receipt of this addendum by inserting its number and date in the Bid Proposal.

Changes/Additions to the Bid Documents:

THIS ADDENDUM is hereby made a part of the contract documents on the subject work as though originally included therein. The following amendments, additions and/or corrections shall govern this work.

This Addendum is in the following parts as follows:

- | | |
|----------|--|
| Part I | - Pertaining to Drawings |
| Part II | - Pertaining to Technical Specifications |
| Part III | - Clarifications to Contractor's Questions |
| Part IV | - List of Attachments |
| Part V | - Additional Information |

PART I - PERTAINING TO DRAWINGS

1. Project Clarification: All required work from Station 109+29 to 113+96 shall be excluded from the Lump Sum Base Bid Price and included in Alternate #4. Refer to the description within this Addendum for further details.
2. Project Clarification: All required work from Station 372+36 to 373+85 shall be excluded from the Lump Sum Base Bid Price and included in Alternate #5. Refer to the description within this Addendum for further details.
3. Project Clarification: Sheet ANGP-T-G-006 – Construction Type W shall utilize 3/8" OSB (or equivalent) for spoil stockpiles in the same manor that Construction Type A utilizes 3/8" OSB (or equivalent).

PART II - PERTAINING TO TECHNICAL SPECIFICATIONS

1. Bid Form
 - a. ADD "Alternate # 4 Price" to Section 4.
 - b. ADD "Alternate # 5 Price" to Section 4.
2. Bid Summary Form
 - a. Clarification: Section 1.0 Schedule of Values, Item 10 "12" Pipe Installation – Roads and RR (Jack & Bore)" shall not include work described in Alternate No. 4 and No. 5 as detailed within this Addendum. ADD line items for Alternates #4 and #5 to the Schedule of Values after the existing Alternate #3 line item (Alternate 3 was added in Addendum 1).

- b. Section 3.0 Unit Price Schedule: ADD a unit price for “extra depth ditch beyond called for on plans or indicated in Contract Documents”. The unit shall be linear foot of pipe per extra foot of depth.
3. Specification Section 012300 Alternates
- a. ADD Item 3.1.D as follows:
- D. Alternate No. 4 – Jack and Bore Alternative (Sta. 109+29 to 113+96)
1. Alternate #4 shall include all required work, as shown on the plans, for a complete installation of all piping, cases, appurtenances and all other associated components from Sta. 109+29 to 113+96. Contractors may submit an alternate installation solution without a casing – indicate the installation method as well as the cost deduct (if applicable) of this Alternate with the bid submission. The alternate installation solution shall meet specifications for Genesee and Wyoming Railway Crossings (New England Central Railroad locations) – refer to attached documents.
- b. ADD Item 3.1.E as follows:
- E. Alternate No. 5 – Jack and Bore Alternative (Sta. 372+36 to 373+85)
1. Alternate #4 shall include all required work, as shown on the plans, for a complete installation of all piping, cases, appurtenances and all other associated components from Sta. 372+36 to 373+85. The crossing is currently shown as a horizontal crossing with 11.1’ of cover below the tracks – this may be modified and the casing/carrier installed with a vertical angle, as long as a minimum separation from the tracks to the top of casing is 6.5’. Contractors may submit an alternate installation solution without a casing – indicate the installation method as well as the cost deduct (if applicable) of this Alternate with the bid submission. The alternate installation solution shall meet specifications for Genesee and Wyoming Railway Crossings (New England Central Railroad locations) – refer to attached documents.

PART III – CLARIFICATIONS TO CONTRACTOR QUESTIONS

1. **Q:** “Currently, we would like to bid all three contracts of the Addison Natural Gas Project. In order to maximize economies of scale and better utilize resources, we request the bids for all contracts be due on 11-20-13.” **A:** The bid due dates for the Distribution Contract and Meter & Regulation Contract are rescheduled for November 20, 2013 at 2:00 p.m.
2. **Q:** “Is there a physical address to which we can overnight the hard copy proposal? The P.O. Box address in the RFP will only accept documents via USPS.” **A:** Yes. Hard copies can be overnight shipped to: 90 Mechanicsville Road, Suite 7, Hinesburg, VT 05461”
3. **Q:** “Will all access roads be constructed prior to the commencement of M&R construction?” **A:** The scope of work, scheduling and coordination of the access roads are included in the Transmission Contract – Refer to Specification Section 011000 “Summary” that was issued in Addendum 1.
4. **Q:** “The application for underground pipeline crossing or parallelism of RR property. ‘Upon application approval, applicant agrees to reimburse RR for any costs incurred by RR incident to a installation, maintenance and or supervision necessitated by the installation’ As the bidders at this time do not know what these costs would be, can the bidders expect a change in contract when the costs become known to the owner and contractors?” **A:** Yes. The costs to reimburse the railroad company for any required supervision will be the responsibility of VGS. The Contractor is responsible for

coordination and scheduling these activities with the Construction Manager and/or applicable railroad personnel.

5. **Q:** *“Who will unload the HDD pipe in Swanton? Please confirm that the owner will unload all pipe.”* **A:** Refer to Specification Section 012300 “Alternates”, Part 3.1.B that was issued in Addendum 1. If Alternate 2 is selected by VGS, the Transmission Contractor is responsible for receiving and offloading pipe deliveries in Swanton, VT. If Alternate 2 is not selected by VGS, the receiving and offloading pipe deliveries in Swanton will be the responsibility of the HDD Contractor (ECI).
6. **Q:** *“Minutes of the meeting. “The contractor is to provide the On-Site Coordinator (OSPC) VGS is to provide the EPSC specialist.” At the prebid meeting it was stated that the (OSPC) is by the owner and the EPSC is by the contractor. Please clarify. If the contractor is required to provide the OSPC will he need to be a PE or have other credentials? If the contractor is responsible for the EPSC can he be a working foreman?”* **A:** This was written in the meeting minutes in error. The OSPC will be provided by VGS.
7. **Q:** *“Will the contractor be able to use the Williston and Plank Road pipe yards for their staging areas?”* **A:** Yes. The intent of the Williston and Plank Road Pipe Yards is for contractor staging areas. In addition, the pipe yards are intended for pipe storage, office trailers (both Construction Manager and Contractor), equipment storage, temporary facilities, and other items necessary for the completion of the project.
8. **Q:** *“Will there be a separate yard for storing the 4000 mats and if so who is responsible for it? Please confirm that others will be delivering and unloading them.”* **A:** The 4,000 owner supplied mats will be stored at the Williston and Plank Road Pipe Yards. VGS will deliver and offload the mats to the Williston and Plank Road Pipe Yards. If the Contractor acquires a staging area independently at a different location, VGS will deliver to that location and the contractor will offload. VGS assumes that if the Contractor obtains an independent staging area, it will be within reasonable distance to either the Williston or Plank Road Pipe Yards (within a 20 mile radius).
9. **Q:** *“B.1 Contractor shall arrange and pay for delivery of owner furnished items. Please confirm the delivery will be from the VGS yard in Burlington or other local storage yards to the job site.”* **A:** Owner furnished items will not be stored at the VGS yard in South Burlington. Owner furnished items will be stored in several storage containers at a location within 40 miles of Burlington. The Contractor will be responsible for providing support systems for equipment furnished by VGS as detailed in Specification 011000 Summary, Part 1.5.B.
10. **Q:** *“The preliminary Geotechnical investigations report para 5.3.3 water control states “The dewatering can be accomplished through the use of sump pumps and diversion trenches with discharge downslope”. If an unusual condition such as a quick condition occurs that would, for instance require deep wells at the RR bores or well points on the mainline, would this be an extra in the contract price?”* **A:** No. Contractor shall assume all risk and associated costs with dewatering. Dewatering means and methods are the responsibility of the Contractor.
11. **Q:** *“How many factory bends will be supplied? What will be the wall thickness of the factory bends? Will the factory bends be transitioned?”* **A:** An adequate quantity of bends will be supplied by VGS. The wall thickness of the bends will be 0.375”. The factory bends will be transitioned.
12. **Q:** *“HDD- If required by the company the contractor shall keep a 24 hour security on the pullback section. Who is responsible for this, the mainline contractor or the HDD contractor? If it is required will this be an extra?”* **A:** Refer to the Transmission Pre-Bid Minutes of Meeting, Item 3.3, which notes “Security requirements at HDD sites is the responsibility of the HDD contractor”.

13. **Q:** *“Is a full time quality control inspector required?”* **A:** A full time quality control inspector is at the contractor’s discretion. The quality of the work shall meet or exceed the requirements specified or referenced in the Project Manual and Project Manual Attachments.
14. **Q:** *“Is a full time safety inspector required?”* **A:** A full time safety inspector is at the contractor’s discretion. Contractor shall be responsible for initiating, maintaining and supervising all safety precautions and programs in connection with the Work. Refer to Section 6.21 of the General Conditions for requirements of Safety Representatives.
15. **Q:** *“Can the 35 million insurance limit be satisfied with a combination of primary and umbrella rather than a specific need for a 10 million primary general limit and a 25 million umbrella?”* **A:** Yes.
16. **Q:** *“Is a bid bond required?”* **A:** A bid bond is not required. Only Performance and Payment Bonds will be required by the selected Contractor.
17. **Q:** *“Will the contractor be paid for the rock bores?”* **A:** No. Rock encountered during jack and bore operations will be the responsibility of the contractor. No extra rock costs will be paid by VGS.
18. **Q:** *“Ref 401 WQC application ltr to Mr Allen Quackenbush dtd July 10, 2013. Are the shifts mentioned and the 34 additional areas that have been reduced from 75 to 50’ shown on the bidding drawings?”* **A:** The reduced work areas are indicated on the drawings.
19. **Q:** *“Will boulders over one cubic yard be paid for as rock. Will the rock unit be used for rock bores?”* **A:** Rock, and boulders defined as rock, is detailed in Specification Section 312316.26 “Rock Removal”, Item 1.3.A. No. Rock encountered during jack and bore operations will be the responsibility of the contractor. No extra rock costs will be paid by VGS.
20. **Q:** *“Are all of the EPSC requirements on the EPSC drawings or does the contractor need to reference other documents?”* **A:** No, all EPSC requirements are not on the EPSC drawings. The anticipated EPSC requirements on the EPSC Plan are shown to the best of our ability prior to issuance of the Individual Construction Stormwater Discharge Permit (INDC). Once the INDC is issued, it will also serve as a reference for EPSC requirements. The contractor shall review all components of the EPSC plans (notes, details, typicals), as not all requirements are shown just on the plan view sheets. The contractor shall comply with all EPSC measures defined in the Contract Documents.
21. **Q:** *“Is there a specification on the 1 1/2” concrete Pipe coating?”* **A:** Yes. Refer to Vermont Gas Addison Natural Gas Project Scope of Work and Specifications, Item 20.
22. **Q:** *“Please provide a complete list of contractors that attended each pre bid meeting on 10-8-13.”* **A:** The Pre-bid Meeting sign in sheet was included as an attachment to Addendum 1.
23. **Q:** *“Will the bidding contractors be able to access the site before the bid?”* **A:** Yes. The following dates will be available for field visits: 10/31/13 and 11/7/13. Refer to Tim Peer’s 10/24/13 email for additional information.
24. **Q:** *“Will the bidding contractors be able to dig test holes prior to the bid? If yes who should we contact to do this?”* **A:** No. Contractors are not allowed to dig test holes prior to the bid.
25. **Q:** *“Can the bidding contractors get a copy of the NGA/VGS Operator Qualifications written plan and will this plan list the covered tasks applicable to this project?”* **A:** Yes. The covered tasks by job title descriptions are attached to this Addendum. It covers the tasks applicable to this project.
26. **Q:** *“Will rock bores be at a negotiated price.”* **A:** No. Rock encountered during jack and bore operations will be the responsibility of the contractor. No extra rock costs will be paid by VGS.

27. **Q:** *"Bid para 30 Unit Price schedule equipment rental, "Equipment rental rates shall not exceed 60% of the rental rate bluebook. Is this meant to apply only to the contractors equipment and rented equipment to be billed at cost plus 10%? If not this would be a direct out of pocket loss of 40% to the contractor."* **A:** Your interpretation is correct. Contractor's equipment shall not exceed 60% of the rental rate bluebook. Rented equipment shall be billed at cost plus 10%.
28. **Q:** *"What is the test pressure for the mainline?"* **A:** 2,160 psi.
29. **Q:** *"What is the pretest and prior test pressure for the HDD and other crossings."* **A:** 2,160 psi.
30. **Q:** *"Addendum #1. Para 26 w. Will the second test (after installation) be in addition to the mainline test. Does this also apply to the HDDs."* **A:** This applies to HDD sections installed by ECI. The mainline hydrostatic test will include all transmission main (including HDD sections).
31. **Q:** *"Addendum #1. "specified crossings" Is there a list of the specified crossings that required a hydrotest?"* **A:** Specified crossings shall be all crossings in the HDD contractors scope of work.
32. **Q:** *"Hydrotesting testing section 26. Will all the requirements set forth for hydrotesting the mainline (section 26) also be the requirement for pretesting and testing after installation of the HDDs and other specified crossings. Example: dead weights and charts on both ends, cleaning, drying etc. If not could we have a separate spec for the pretest and after test. I suggest that we keep this pretty simple."* **A:** The HDD pre/post hydrostatic testing will be identical to the mainline hydrostatic test, with the exception of the duration. 4.25 hours for pre/post HDD hydrostatic test and 8.5 hours for the mainline hydrostatic test.
33. **Q:** *"VGSOM states the contractor exposes the existing line every 200 feet. Elsewhere in the specifications it states the company will expose the existing line. Please advise."* **A:** The Contractor will be responsible for exposing the existing line every 200 feet. The existing gas transmission main is only located in the first 500 feet of the project near the Colchester Tie-In Site.
34. **Q:** *"Scope of work para 9. Will the branch welding test be a full branch or a 2" nipple?"* **A:** Full branch will be required.
35. **Q:** *"Scope of work para 6 b 3rd sentence. "at the contractors expense to provide the necessary archaeological and environmental clearances" Based on your experience can you tell us how long you think this will take?"* **A:** This can vary significantly depending on the site and is nearly impossible to give an estimated duration. Sites that have been previously disturbed or are currently being utilized for similar activities typically can proceed much faster than a site that has never had earth disturbance and/or has environmental resources.
36. **Q:** *"Scope of work para 7 r. 18" clearance. VGSOM states 12". Does the VGSOM supersede the Scope of Work? The VAOT section 1111 permit drawings show a min of 12". Please advise."* **A:** VGSOM supersedes the Scope of Work. Scope of work paragraph 7.r. should read 12" of clearance.
37. **Q:** *"Scope of work 12 a & b. Will the contractor be required to use both padding material and rock shield or just one or the other."* **A:** Both padding and rock shield shall be utilized.
38. **Q:** *"scope of work 13 i. The company "may require" the contractor to use select fill trench bottom padding material. If the contractor is required will this be a extra?"* **A:** No. Costs for select material will be the responsibility of the contractor. On-site material can be screened or commercial material can be imported.
39. **Q:** *"Scope of work 13 r. If the subsoil is not suitable for backfilling and compaction the contractor shall provide select fill material, backfill and compact. No additional*

compensation will be paid to the contractor for any **COMPACTION**. Will the contractor be paid for supplying the select material?" **A:** No. Costs for select material will be the responsibility of the contractor. On-site material can be screened or commercial material can be imported.

40. **Q:** "Scope of work i. Is there any need to use the structured pipe pillows if you are using compacted bedding material?" **A:** Yes – both shall be provided.
41. **Q:** "Scope of work i. If you use the structured pipe pillows will there be a need to used compacted bedding material?" **A:** Yes – both shall be provided.
42. **Q:** "Will the contractor have the option to use rock shield in lieu of select bedding and padding material?" **A:** No – both shall be provided.
43. **Q:** "Is a full time safety inspector required on the mainline? distribution? stations? HDDs?" **A:** A full time safety inspector is at the contractor's discretion. Contractor shall be responsible for initiating, maintaining and supervising all safety precautions and programs in connection with the Work. Refer to Section 6.21 of the General Conditions for requirements of Safety Representatives.
44. **Q:** "The EP&SC plan narrative July 3 2013 para l states, "Project construction is not intended to result in off-site waste disposal" This implies that there are disposal sites on site. Does the bidding contractor figure no off site waste disposal?" **A:** The contractor shall obtain permit coverage from the Vermont Department of Environmental Conservation (DEC) prior to the use of any support activities occurring outside of the approved project boundaries (e.g. equipment staging areas, material storage areas, excavated material disposal areas and borrow areas). Support activities outside of the approved project boundaries shown in the EPSC Plan shall obtain coverage by amending this permit, or by obtaining coverage under a different individual discharge permit or under DEC's General Permit for Stormwater Runoff from Construction Sites. Any additional areas for support activities not indicated on the project plans shall be submitted to the Owner for approval prior to use.
45. **Q:** "011000 Summary 1.3 c (2) the owner/engineer will require a construction office trailer adjacent to any location the mainline contractor sets up facilities for their own use. If the use is for the owner/engineer will this field office need to meet the specs for the construction managers office 24x60. 65124 page 5 of 12 section 01500. If the use is for the contractor does it need to meet any spec? Please advise." **A:** The owner/engineer/construction manager will all utilize the same construction office, which is detailed in Specification 015000. There is not a specification or requirement for the contractor's trailer/office. The location of the owner/engineer/construction manager office will be located generally adjacent to the contractor's field office. Field offices are acceptable, and preferred, at the Williston Pipe Yard.
46. **Q:** "Page 3 of 6 section 017300 3.4 field engineering A "VGS will have the pipeline alignment staked along the centerline of the proposed pipeline. Survey stakes will be set at a min of 200 feet. Confirm that these stakes will have station numbers." **A:** Not confirmed. Layout stakes along the pipe centerline will NOT be stationed.
47. **Q:** "Can you tell us who your surveyor will be?" **A:** The surveyor for the project layout has not yet been determined.
48. **Q:** "Page 2 of 6 017300 B Please explain "Examine substrate TWS and ATWS area LR2 and condition with installer or applicator." **A:** Delete "LR2".
49. **Q:** "31233 page 5 of 6 3.80 Who is responsible for the in place density testing?" **A:** VGS is responsible for in place density testing.
50. **Q:** "The local/town permit folder is still empty." **A:** Correct. The local/town permit applications have not yet been submitted. It is anticipated that these will be submitted in the next few weeks. Once submitted, the permit applications and attachments will be uploaded to the project ftp site.

51. **Q:** *“Mr. Michael Adams letter dtd July 10, 2013 page 6 ” There would be no stumping or grubbing during tree clearing activities within wetlands prior to construction except for areas where the trench would be excavated for pipeline installation. EPSC Plan sheet ANGP-Y-011 EPSC note #4 says the same thing. It is this writer’s opinion that stumps need to be removed in order to place the mats.”* **A:** Clearing crew work that follows the Acceptable Management Practices to Maintain Water Quality on Logging Jobs in Vermont (AMPs), which was issued as part of Addendum 1, will not be under the jurisdiction of the Individual Construction Stormwater Discharge Permit (INDC) and the EPSC Plan. Grinding stumps to the existing grade to install temporary mats will be acceptable to AMP’s. Once stumping and grubbing begins, the disturbed area will be under the jurisdiction of the Individual Construction Stormwater Discharge Permit (INDC) and the EPSC Plan.
52. **Q:** *“The profile drawings issued for VAOT 10 section 1111 permit ANGP-VAOT-002 station 36+00 shows a 20 foot deep trench. The bid mainline profile drawings do not show the depth of the mainline. Are we supposed to bid the project with the specified 3’ 4’ and 5’ cover and anything other than that will be a extra?”* **A:** A rough sketch of the area in question has been created and is attached to this addendum titled “ANGP-VAOT-002 Rev1”. In general, the depths of the transmission main are indicated in several documents, including, but not limited to: MOU’s, Construction Line List, and Permitting Applications. If the depth is shown or noted on the bidding documents, it shall be included in the lump sum base price. If new conditions regarding pipe depths are issued after the bid is submitted, these locations will be paid for as an extra. This unit price extra has been added to Section 3.0 of the Bid Summary Form.
53. **Q:** *“The same drawing issued VAOT 19 section 1111 permit show the profile of the HDDs. At what depth should the mainline contractor plan on for the tie-in to the HDDs?”* **A:** The mainline contractor should plan on the tie-in depths being at, or near, the applicable minimum depth of cover indicated in the Contract Documents.
54. **Q:** *“The alignment shown on the VAOT 19 section 1111 permit drawings are different than the mainline drawings. Which drawings do we use to bid the job?”* **A:** The mainline alignment sheets take precedence over the VAOT permit drawings.
55. **Q:** *“How many OQ tasks will we need to qualify to?”* **A:** There is not a specific number that the Contractor needs to qualify for. Personnel will need to be qualified on any task they are working on that is listed in the OQ tasks. Reference the OQ List attached to this addendum.
56. **Q:** *“DWG # ANGP-T-C-046 shows access road Y but it is not shown on the electric version and the electric version says access denied (Mr. Baldwin) Please clarify. The same goes for ANGP-T-C-047 access road AJ.”* **A:** Access Road Y is detailed on sheet G-009. Access Road AJ is detailed on sheet G-007A.
57. **Q:** *“Where do we find the meaning for labels such as 2012-PW-95 (111), 2012-NS-1 (111), VTAD -483, LOCUS 2, 2012 -JB-31 (111) 2013-CM-3 (11) VT AD-808 LOCUS 1?”* **A:** Refer to “Additional Environmental Notes” on EPSC Plan Sheet ANGP-T-G-011.
58. **Q:** *“The RR bore pits are up to 25 feet deep. Can we bring the line up to 5 feet with 90 degree ells inside the receiving and bore pits or do you want them brought up as shown on the NECRR transmission pipeline crossing detail?”* **A:** 90 degree ells in the receiving and bore pits will not be permitted. Refer to further details in Alternate 4 and Alternate 5 for the railroad crossings.
59. **Q:** *“ANGP-T-C-0054 NERR 8” casing pipe. Is the mainline contractor responsible for the bore. It does not show up on the list of bores. I would suggest you make provisions to have the distribution pipe brought up 3 feet of cover while the steel sheets and deep wells are present.”* **A:** ANGP-T-C-054 does not have a railroad crossing. Assuming the question is for ANGP-T-C-005A: The distribution pipe must remain at the depth shown

on the plans. It is the responsibility of the mainline contractor – refer to Specification 011000 “Summary”.

60. **Q:** “How long are the 4000 mats that are furnished?” **A:** Mats are 4’x16’ per Specification 01100, Section 1.5.A.3.
61. **Q:** “From station 1640+00 to 1666+00 the drawings show additional matting/temporary work space on the opposite side of the trench ROW. Can this be an option for the contractor?” **A:** The 20’ temporary workspace on the east side of the VELCO overhead lines is intended for a traveled way.
62. **Q:** “Contract documents shows a HDD from 1774+50 to 1789+50 but it is not on the HDD location lists. Is this a HDD?” **A:** Refer to the Construction Type band on the alignment sheets for method of pipe installation.
63. **Q:** “If the mats on the alignment drawings do not serve a purpose for the mainline contractors (example mats over the HDDs) do these mats go into the Alt No 2 HDD support price?” **A:** Mats for HDD support are part of Alternate No. 2. Refer to Specification 012300, Section 3.1.B.1.c.
64. **Q:** “Do we test the valves individually or can we test them all together?” **A:** This can be determined by the Contractor. All valves must pass the applicable testing requirements.
65. **Q:** “Reference Coler and Colantonio VAOT 19 & VSA & 111 permit application. We are missing the profile drawings from ANGP-T-C-035A to 083A” **A:** Applicable VTrans permitting drawings are available on the project ftp site.
66. **Q:** “Do you have the depth of the proposed 48” culvert at sta 459+60?” **A:** No.
67. **Q:** “Do you have the depth of the 42” proposed culvert at stat 538+91?” **A:** Yes - The proposed invert is 385.00’.
68. **Q:** “Do you have the depth of the proposed 24” culvert at sta 608+00?” **A:** No.
69. **Q:** “Please explain the VAOT 19 section 1111 permit drawings profile of HDD. They show us tie-ing in to the HDDs at depths of up to 30’.” **A:** HDD tie-ins shown on the VTrans 1111 Permit Drawings appear to be at 30’ of depth due to the difference in horizontal vs. vertical scales. Tie-ins will be at the required cover based on the area of work.
70. **Q:** “When will the proposed road and utility construction began?” **A:** The road and utility construction work start date has yet to be determined.
71. **Q:** “Will the owner’s layout include line and grade at the proposed utility locations?” **A:** No.
72. **Q:** “Will the drawings for construction show the stations and elevations of the proposed utilities?” **A:** No.
73. **Q:** “Minutes of the pre-bid meeting: Bidding documents 2.6 Bidder to provide a cost for providing powercrete coating on pipe. Should this not read “concrete weight coating”?” **A:** This should read “concrete weight coating”.
74. **Q:** “Minutes of the pre-bid meeting: Post Meeting Clarifications. Alternate 4 is void and not included in the project manual. I’m confused. Are you not asking us for a alternate 4 price?” **A:** In the Prebid meeting, Alternate 4 was described as the field applied concrete coating completed by the contractor. This was in error as the field applied concrete coating was already in the total lump sum base bid price (Item 20 of the ANGP Specification and Scope of Work). Alternate 4 is now re-defined by this addendum.
75. **Q:** “Please clarify that the 40,000’+- field applied concrete weight coating is included in the base contract.” **Q:** Field applied concrete weight coating is included in the base contract. Approximate quantities are listed on the “Material Quantities” table on Sheet ANGP-T-G-003.
76. **Q:** “Will the joint coating for the concrete weight pipe be a 2 part epoxy or a canusa sleeve?” **Q:** If the coating is pritec, Canusa sleeves will be utilized. If the coating is ARO/FBE, 2-part epoxy will be utilized.

77. **Q:** “Where a field bend is required in areas of concrete coated pipe will the owner be supplying 3r factory bends or fittings?” **A:** Yes – VGS will supply bends/fittings.
78. **Q:** “Will the coating for these bends be two part epoxy?” **A:** If the coating is pritec, Canusa sleeves will be utilized. If the coating is ARO/FBE, 2-part epoxy will be utilized.
79. **Q:** “To what extent do we use the Coler and Colantonio drawings and information? Are these part of the contract documents?” **A:** The Coler and Colantonio drawings and information were utilized for the VTrans 1111 permit application package. These are a part of the Contract Documents. However, the CHA Alignment Drawings and CHA/VHB EPSC Drawings take precedence when there is a discrepancy with the drawings associated with the VTrans 1111 Permit Application.
80. **Q:** “Note: Coler and Colantonio dwg ANGP-VAOT-013 are different than CHA drawings ANGP-T-C-013.” **A:** The CHA Alignment Drawings and CHA/VHB EPSC Drawings take precedence when there is a discrepancy with the drawings associated with the VTrans 1111 Permit Application.
81. **Q:** “Coler & Colantonio dwg ANGP-VAOT-019 profile. Note: Min depth of cover 5' within Route 289 corridor (Typ) Typical. Same dwg says min depth of cover 3' outside of Route 289 corridor. Please confirm that you do want a minimum depth of cover in all of the Route 289 corridor. If the minimum depth of cover is 5' in parts of the corridor could you give us stations to station numbers.” **A:** The minimum depth of cover within the Route 289 corridor shall be 4'.
82. **Q:** “Are we responsible for imported select fill and haul away for all of the trench in the Route 289 corridor? If not to what extent are we responsible for select fill in the corridor?” **A:** Yes.
83. **Q:** “Coler & Colantonio dwg. Note on profile. Maintain min depth of cover under 6" ud sand cushion of 3'. Is this typical for all 6" ud crossings in the 289 corridor or just in this location? At this location it puts the 12" line at 12 feet deep.” **A:** A specific drawing was not listed with this question and we are unable to locate the note. Minimum depth of cover in the 289 corridor shall be 4'.
84. **Q:** “Note: Coler & Colantonio dwg ANGP-T-C-021A shows a 600' HDD. Not shown of CHA dwgs.” **A:** The CHA Alignment Drawings and CHA/VHB EPSC Drawings take precedence when there is a discrepancy with the drawings associated with the VTrans 1111 Permit Application. There is not a 600' HDD in the referenced location.
85. **Q:** “Scope of Work - Section 4 (Clearing)(B) - States that CONTRACTOR is responsible for exposing and flagging existing VGS hot line. Scope of Work - Section 7 (Trenching)(X) - States that COMPANY is responsible for exposing and flagging existing VGS hot line. Please confirm which party will be responsible CONTRACTOR or COMPANY for exposing and flagging existing VGS hot line.” **A:** The Contractor will be responsible for exposing the existing line every 200 feet. The existing gas transmission main is only located in the first 500 feet of the project near the Colchester Tie-In Site.
86. **Q:** “Please identify the (20) wash down location stations.” **A:** The exact location of the wash down stations has not yet been determined. For bidding purposes, Contractors shall assume 20 equally spaced wash down stations for the length of the Transmission Main.
87. **Q:** “There are several different references to “No Construction Phase” in the alignment sheets can you define each and what will and will not be allowed in each example. See below:”
- a. ANGP-T-C-002: STATION 48+50 NO CONSTRUCTION PHASE VEGETATION REMOVAL UNDER HDD **A:** Construction phase activities including clearing, grubbing, and any earth disturbances will not be allowed in this area.
 - b. ANGP-T-C-003: STATION 55+00 NO CONSTRUCTION PHASE VEGETATION REMOVAL UNDER HDD **A:** Construction phase activities including clearing, grubbing, and any earth disturbances will not be allowed in this area.

- c. *ANGP-T-C-003A: STATION 67+91-84+60 NO CONSTRUCTION PHASE VEGETATION REMOVAL UNDER HDD A: A:* Construction phase activities including clearing, grubbing, and any earth disturbances will not be allowed in this area.
- d. *ANGP-T-C-047: STATION 1207+25-1221+00 NO CONSTRUCTION PHASE VEGETATION REMOVAL UNDER HDD A:* Construction phase activities including clearing, grubbing, and any earth disturbances will not be allowed in this area.
88. **Q:** *"Can you please identify any "No Construction Phase" locations not listed above?"*
A: All "No Construction Phase" locations are noted on the plans.
89. **Q:** *"Alignment sheet ANGP-T-C-067: Station 1696+00-1712+50, shows construction type (8), with coating type (C). This is not shown as an HDD on the alignment sheet, but is listed as an HDD in the Transmission Addendum Item(9) "24381 JB, Crossing, HDD Tables.pdf, Item(11) "ANGP HDD Durations.pdf." Can you please confirm if this is an HDD, and exactly which type of coating will be used."* **A:** Confirmed. Construction Type 8 is an HDD installation. All HDD coating types shall be "B".
90. **Q:** *"There is a discrepancy in HDD lengths and stations in the project plan ANGP-ALIGN-TRANS / 24381 JB, Crossing, HDD Tables / HDD Durations.pdf. Each document is showing different start/stop station points and different HDD lengths. Can you please confirm which document shows the correct HDD lengths and Stations?"* **A:** HDD stations shall be per the Alignment Sheets. The JB, Crossing, HDD Tables and the HDD Durations are included in the "Information Available to Bidders" Section and are not part of the Contract Documents. Refer to the language written in the Information Available to Bidders Section of the Project Manual.
91. **Q:** *"Alignment Sheet ANGP-T-C-018: Station 474+00 shows, 16" water main to be capped and abandoned. Is this part of the Transmission Main Line Contract?"* **A:** No, this is not part of the Transmission Contract.
92. **Q:** *"Where will the owner supplied 4,000 construction mats be received by contractor as referenced in Section 11000 Summary 1.5 Owner Furnished Products (A) and Scope of Work 32. Materials and Equipment Supplied by the Company? Where will the (re-usable) owner supplied mats be transported, after construction is complete? A portion of mats will be damaged beyond use during construction, what is the approved method and location, of disposal and does this cost need to be included in the Transmission Main Line Bid?"* **A:** The 4,000 owner supplied mats will be stored at the Williston and Plank Road Pipe Yards. VGS will deliver and offload the mats to the Williston and Plank Road Pipe Yards. If the Contractor acquires a staging area independently at a different location, VGS will deliver to that location and the contractor will offload. VGS assumes that if the Contractor obtains an independent staging area, it will be within reasonable distance to either the Williston or Plank Road Pipe Yards (within a 20 mile radius). Disposal of mats that are damaged beyond use will be the responsibility of the Transmission Contractor. Delivery of mats that are able to be re-used at the end of the Project will be to the Plank Road Pipe Yard – transportation and unloading will be the responsibility of the Transmission Contractor.
93. **Q:** *"Section 11000 Summary 1.5 Owner Supplied Products (a) and (b) and Scope of Work 32. Materials and Equipment Supplied by the Company, state that the Contractor is responsible for arranging all transportation, supplying all equipment and labor to accept any and all Owner Supplied Materials and Equipment, and that all costs shall be born to the Contractor."*

Section 11000 Summary 1.3 Work Under the Transmission Mainline Contract 2.(a)1) states that the owner will receive the pipe at the Williston Pipe Yard.

Can you please confirm that the Owner is responsible for arranging transportation and receiving all of the pipe and is responsible for any and all labor, equipment, transportation costs associated with the pipe transportation and receiving process (excluding the pipe required for Bid Alternate 2 - HDD as defined in Section 12300 Part 3 (b)(1)(A))?” **A:** Confirmed. Owner will be responsible for all costs associated with deliver, transportation and unloading of Company/Owner supplied equipment, with the exception of pipe required for Bid Alternate 2.

94. **Q:** *“Will the owner accept a bid alternate to use PipeSak Pipe Weights in lieu of the concrete coating? Preliminary cost projections show a direct savings to the owner in the amount of [REDACTED]. In addition to the direct savings to the owner, this will increase production based on the fact that twice as much uncoated pipe can be hauled on one truck load vs. the concrete coated pipe.”* **A:** The Owner will consider additional alternatives to the base bid as described in this question. The Owner requests that the contractor bids the job as currently specified, however, provides deduct alternatives with detailed descriptions of the proposed change in scope. Please note: In areas proposed by the Contractor for the PipeSak Pipe Weight alternative to concrete coating, rock shield must be utilized. Imported fill will not be accepted in wetland areas.
95. **Q:** *“Will the owner accept a bid alternate to use sand bags for the pipe to rest on in rock areas in lieu of PipeSak Pipe Pillows? Preliminary cost projections show four sand bags spaced at 15ft intervals vs. one pillow is a direct savings to the owner in the amount of [REDACTED].”* **A:** The Owner will consider additional alternatives to the base bid as described in this question. The Owner requests that the contractor bids the job as currently specified, however, provides deduct alternatives with detailed descriptions of the proposed change in scope.
96. **Q:** *“Several of the access roads show reinforced perimeter control in the wetland areas, there are several roads that will have to be constructed for use, and several roads that are existing that will just need to be repaired and maintained throughout the construction process. Can you please confirm if and where construction demarcation will be required along access roads.”* **A:** Construction demarcation will be required along the entire length of access road as a means of denoting where project equipment can and cannot go, and where project activities can and cannot occur. Recall that demarcation does not necessarily need to be orange construction fence; there are other options – see EPSC Plan Sheet ANGP-T-G-012, Detail 1.

With regard to reinforced perimeter controls, those need to be installed where earth disturbance is within 50 ft upslope of a water resource area (stream, wetland). For areas where earth disturbance will be >50 ft from a water resource area, perimeter controls do not need to be reinforced. See EPSC Plan Sheet ANGP-T-G-012, Detail 2.

For new access roads (or new sections of access road), perimeter controls may be needed if there's a pitch to the road that may cause runoff from the disturbed area to either leave the project site or enter a water resource area (or both). In these cases, “disturbed area” is considered to be any new fill, newly graded area, newly excavated area, etc that is not stabilized with stone or by compaction sufficient enough to not erode.

97. **Q:** *“Will construction demarcation and perimeter control be required in areas where no travel or construction occurs? Examples: Sand Plain Forest 67+91-84+60, Monkton Swamp 1439+50-1468+75.”* **A:** In areas where there will be absolutely no access by any type of equipment (including pick-up trucks, ATVs, or guys on foot with a chainsaw) or any type of project-related activities (including vegetation clearing), construction demarcation is not necessary. Similarly, in areas where there will be absolutely no earth

disturbance, perimeter controls are not necessary. This is also true for active access ways (e.g., driveways, farm roads) and flowing water (e.g., streams): construction demarcation and perimeter controls should not cross either of these.

98. **Q:** “Where is the pipe coming from?” **A:** This will be clarified in Addendum 3.
99. **Q:** “On the Legend page ANGP-T-G-003 there is a symbol for temporary wetland impact. On the EPSC drawings on the left of the page there is the same symbol that stands for temporary wetland matting. This symbol is not on the alignment drawings. On the EPSC drawings there are notes “Install Matting sta to sta.” On Dwg ANP-T-6-006 there is a detail that says “install matting per EPSC plans. This drawing also shows matting full width of the ROW. Does the contractor consider that the symbol is “temporary wetland impact” and install the matting from station to station as noted as he feel is necessary to accomplish the work or does the contractor install the matting from station to station as noted plus whatever the symbol covers on the drawing. If so this would require matting full width of the ROW. If this is your intent the project will required over 28,000 mats. If the intent of all these matts is to keep the soil separated can we use the OSB board in lieu of the matts? Again can the contractor install the matting from station to station as noted on the EPSC drawings to the width he feel necessary to accomplish the work?” **A:** This will be clarified in Addendum 3.
100. **Q:** Are there any restrictions to the time of year we are allowed to open cut the stream crossings? **A:** This will be clarified in Addendum 3.
101. **Q:** “Will the owner accept a cold weather coating product alternative for pipe coated at below 50 degrees ambient temperatures? Example: Denso_7125: <http://www.densona.com/pdfs/DensoLiquidCoatings/Denso-Protal-7125.pdf>” **A:** This will be clarified in Addendum 3.
102. **Q:** “There are several different references to “No Construction Phase” in the alignment sheets can you define each and what will and will not be allowed in each example. See below:”
- a. ANGP-T-C-065: STATION 1639+90-1666+00 NO CONSTRUCTION PHASE WOODY VEGETATION REMOVAL UNDER HDD **A:** This will be clarified in Addendum 3.
 - b. ANGP-T-C-066: STATION 1604+00-1666+50 NO CONSTRUCTION PHASE WOODY VEGETATION REMOVAL UNDER HDD (PLEASE CONFIRM IF THESE STATION NUMBERS ARE CORRECT, THERE APPEARS TO BE A MISTAKE) **A:** This will be clarified in Addendum 3.
 - c. ANGP-T-C-067: STATION 1697+00-1709+25 NO CONSTRUCTION PHASE WOODY VEGETATION REMOVAL UNDER HDD **A:** This will be clarified in Addendum 3.

PART IV – LIST OF ATTACHMENTS

1. Drawing titled “Drainage Plan - sheet D1” produced by O’Leary-Burke Civil Associates, PLC for Chittenden Solid Waste District dated 3-12-12. When the transmission main is located adjacent to or in the proposed drainage improvement areas, the main shall have a minimum of three feet of cover from proposed grades.
2. CV Agreement No. 7092 for New England Central Railroad Crossing in Colchester. Contractor shall meet all applicable conditions within this agreement.
3. CV Agreement No. 7093 for New England Central Railroad Crossing in Williston. Contractor shall meet all applicable conditions within this agreement.

4. Pipeline Specifications for Genesee and Wyoming Railway Crossings (New England Central Railroad locations). Any proposed alternative installations shall conform to these specifications.
5. ANGP-VAOT-002 Rev1 Sketch Plan noting the revision to the proposed pipe elevation.
6. VGS OQ Tasks By Job Title

PART V – ADDITIONAL INFORMATION

1. None.

END OF ENGINEER'S ADDENDUM

Date: October 29, 2013

Submitted by: CHA

V:\Projects\ANY\K3\25158\Construction\Bid\Addendum No2\Addendum 2.doc

DRAFT - NOT FOR CONSTRUCTION

DRAFT - NOT FOR CONSTRUCTION

ENGINEER'S ADDENDUM NO. 03
TO THE BID DOCUMENTS (PLANS AND SPECIFICATIONS) FOR
Proposed System Expansion
Addison Natural Gas Project (ANGP)
Transmission Contract
November 13, 2013

The following changes and/or additions shall be made to the plans and/or specifications. All other requirements of the contract documents shall remain the same. Acknowledge receipt of this addendum by inserting its number and date in the Bid Proposal.

Changes/Additions to the Bid Documents:

THIS ADDENDUM is hereby made a part of the contract documents on the subject work as though originally included therein. The following amendments, additions and/or corrections shall govern this work.

This Addendum is in the following parts as follows:

- | | |
|----------|--|
| Part I | - Pertaining to Drawings |
| Part II | - Pertaining to Technical Specifications |
| Part III | - Clarifications to Contractor's Questions |
| Part IV | - List of Attachments |
| Part V | - Additional Information |

*THE BID DUE DATES FOR THE TRANSMISSION CONTRACT, METER & REGULATION CONTRACT AND DISTRIBUTION CONTRACT ARE **RESCHEDULED FOR DECEMBER 4, 2013 AT 2:00 P.M.** QUESTIONS ARE DUE WEDNESDAY, NOVEMBER 20 AT 2:00. ANSWERS TO QUESTIONS WILL BE ISSUED BY ADDENDUM THE FOLLOWING WEEK.*

PART I- PERTAINING TO DRAWINGS

1. Project Clarification: Porous pavement for permanent access roads shall meet the "UNHSC Design Specifications for Porous Asphalt Pavement and Infiltration Beds". This is attached for your reference.
2. VTrans Drawings – ADD Vermont Agency of Transportation Standard E-119 "Utility Work Zone" to the VTrans Permitting Package.
3. The width of the main line valve permanent access roads (porous asphalt) shall be 12' – REVISE the dimension on Sheet 15-713-C-506 titled "Mainline Valve Site Details". The 12' dimension will then be consistent with the width noted on the General Arrangement Plans (Site Plans).
4. ANGP-T-G-022 and ANGP-T-G-023 – Williston and New Haven Pipeyards: The layout of entrance drives, storage areas, office trailers and other items are for a general arrangement example only. The contractor can elect to configure the pipeyards to be compatible with their means and methods of construction. All configurations shall be compliant with applicable permitting conditions.
5. REVISE the following sheets with the attached sheets/sketches:
 - a. ANGP-T-G-003-SK1
 - b. ANGP-T-G-007A-SK1
 - c. ANGP-T-G-008-SK1
 - d. ANGP-T-G-009-SK1

- e. ANGP-T-G-015 Rev. 2
 - f. ANGP-T-C-013-SK1
 - g. ANGP-T-G-022 Rev. 1
 - h. ANGP-T-C-027 Rev. 2
 - i. ANGP-EPSC-027 Rev. 2
 - j. ANGP-T-C-040-SK1
 - k. ANGP-T-C-047-SK1
 - l. ANGP-T-C-067-SK1
 - m. ANGP-T-C-068-SK1
6. Refer to Part III below for additional clarifications/revisions to project drawings.

PART II - PERTAINING TO TECHNICAL SPECIFICATIONS

1. Bid Form: REPLACE with the attached REVISED Bid Form.
2. Bid Summary Form: REPLACE with the attached REVISED Bid Summary Form.
3. Project Clarification: Select fill (imported sand) for pipe bedding and pipe envelope areas shall be included in the lump sum base bid for the amount shown in the bid summary schedule of values. Adjustments to actual amounts used will be adjusted by the unit price determined by the schedule of value. The Schedule of Values in the Bid Summary Form has been revised. This supersedes the Q/A response in Addendum 2 (#38/39).
4. Project Clarification: Porous pavement for permanent access roads shall meet the "UNHSC Design Specifications for Porous Asphalt Pavement and Infiltration Beds". This is attached for your reference.
5. Contractor shall provide a list of Vermont based resources that will be utilized for the project in the Bid Summary Form, Item 2.0 Project Plan. Resources shall include subcontractors, suppliers, personnel, and other applicable items.
6. Project Clarification: Construction conditions/restrictions noted in the Supplemental Condition Attachments will be the responsibility of the Contractor, including but not limited to: working hours and blasting conditions.

PART III – CLARIFICATIONS TO CONTRACTOR QUESTIONS

1. **Q:** "Where is the pipe coming from?" **A:** The drill (ARO coated) pipe is source from Paragon Mill and is being coated at Womble Coaters in Houston, Texas. The supplier for the balance of pipe has not yet been determined and will be provided in the final addendum if known at that time.
2. **Q:** "On the Legend page ANGP-T-G-003 there is a symbol for temporary wetland impact. On the EPSC drawings on the left of the page there is the same symbol that stands for temporary wetland matting. This symbol is not on the alignment drawings. On the EPSC drawings there are notes "Install Matting sta to sta." On Dwg ANP-T-6-006 there is a detail that says "install matting per EPSC plans. This drawing also shows matting full width of the ROW. Does the contractor consider that the symbol is "temporary wetland impact" and install the matting from station to station as noted as he feel is necessary to accomplish the work or does the contractor install the matting from station to station as noted plus whatever the symbol covers on the drawing. If so this would require matting full width of the ROW. If this is your intent the project will required over 28,000 mats. If the intent of all these matts is to keep the soil separated can we use the OSB board in lieu of the matts? Again can the contractor install the matting from station to station as noted on the EPSC drawings to the width he feel necessary to accomplish the work?" **A:** Clarification of the matting requirements was provided during the pre-bid meeting on October 8, 2013. The purpose of matting is to minimize potential

impacts to natural and cultural/archeological resources by: (1) avoiding direct placement of soil stockpiles onto these areas by creating a barrier between the two, and (2) minimizing soil disturbance (e.g., rutting) within these areas by providing a stabilized surface for equipment and vehicle passage. Construction mats capable of supporting vehicles and heavy equipment shall be installed within areas where equipment access through resource areas is intended, per the matting symbol in the EPSC Plan. For soil stockpiling within resource areas, matting capable of separating stockpiled soil from the ground surface shall be installed to prevent intermixing of the excavated soil with the resource area, per the matting symbol in the EPSC Plan. The same type of matting does not need to be installed from one edge of the ROW to the other. Rather, the intended use of the mats – whether it is for access of heavy equipment or stockpiling soil or some other purpose – shall dictate which type of mat to use while causing no disturbance to the resource area. The Contractor will install the mats necessary to meet the intent of the permit and construction type detail and minimize impacts to the areas noted (keep all work on mats).

3. **Q:** *Are there any restrictions to the time of year we are allowed to open cut the stream crossings?* **A:** It is anticipated that this will be addressed specifically in the Vermont Stream Alteration Permit, which has not yet been issued. For bidding purposes, the Contractor shall assume that open cut stream crossings will be requested to be performed during low-flow conditions typically experienced during the dryer summer months, but possible at any time of year. The actual permit will be issued via Field Directive at which time any impacts to Contractor bid price will be addressed.
4. **Q:** *“Will the owner accept a cold weather coating product alternative for pipe coated at below 50 degrees ambient temperatures? Example: Denso_7125: <http://www.densona.com/pdfs/DensoLiquidCoatings/Denso-Protal-7125.pdf>”* **A:** Pritec coated pipe shall be coated with shrink sleeves in cold weather conditions. HDD (ARO) coated pipe – Owner will review any alternatives provided by the Contractor.
5. **Q:** *“There are several different references to “No Construction Phase” in the alignment sheets can you define each and what will and will not be allowed in each example. See below:”*
 - a. *ANGP-T-C-065: STATION 1639+90-1666+00 NO CONSTRUCTION PHASE WOODY VEGETATION REMOVAL UNDER HDD* **A:** This section is not an HDD. It parallels the VELCO right-of-way.
 - b. *ANGP-T-C-066: STATION 1604+00-1666+50 NO CONSTRUCTION PHASE WOODY VEGETATION REMOVAL UNDER HDD (PLEASE CONFIRM IF THESE STATION NUMBERS ARE CORRECT, THERE APPEARS TO BE A MISTAKE)* **A:** This is a typo “1604+00 should be revised to 1639+00”.
 - c. *ANGP-T-C-067: STATION 1697+00-1709+25 NO CONSTRUCTION PHASE WOODY VEGETATION REMOVAL UNDER HDD* **A:** This is an HDD section. Clearing above HDD area is not permitted.
6. **Q:** *“Would it be possible to get the bid form, bid summary form, certified copy of resolution, and bidder’s qualification questionnaire form for the above project in word format?”* **A:** Yes. These are attached to this addendum.
7. **Q:** *“Will a “revised” Bid Summary Form, Schedule of Values be issued to contractors that list Alternate # 4 Price and Alternate # 5 Price?”* **A:** Yes. It is attached to this addendum.
8. **Q:** *“Please describe in detail what portions of the Williston pipe yard are going to be constructed by VGS, in order to receive pipe (as referenced in Addendum 1).”* **A:** REPLACE the description in Specification 011000, Section 1.3.A.2.a.1 with the following: “1) Williston Pipe Yard: The entire scope of the Williston Pipe Yard is included in the Transmission Contract and is the responsibility of the selected contractor.

The contractor shall coordinate with the construction manager and VGS after the award of the bid for pipe delivery scheduling.

9. **Q:** *“Do all improvements to the pipe yards in Williston and Plank Road need to be removed when construction is complete, if not please detail what will and will not be removed. Example: Stone, Geotextile fabric, Construction Entrances, etc.”* **A:** Yes – all improvements shall be removed when construction is complete.
10. **Q:** *“Can the ATWS near station 374+00 be moved southwest to a flatter area? The current location is on a side hill that appears to be part of the landfill cap so it is unlikely we can do any cut and fill at this to provide a useable ATWS. Due to the bore at this location, we will need the additional working room.”* **A:** This is understood. Due to the past landowner negotiations, the ATWS may not be able to be moved. An alignment change may be considered, however, it must be reviewed by applicable environmental agencies, get archaeological clearance and landowner approval. Alternate #5 gives the contractor an option to utilize an alternate method of crossing the railroad.
11. **Q:** *“The Crossing Tables included with addendum 1 indicate the construction type from station 1696+00 to 1712+50 be performed as an HDD. The construction drawings do not indicate an HDD in this area. Please clarify.”* **A:** The construction drawings note a construction type “8” and “W”, which indicate a HDD installation under a wetland. The table is in concurrence with the drawings in this location.
12. **Q:** *“Transmission Contract, Engineer’s Addendum No. 02, Part II, Paragraph 2, part a, notes a clarification to “Section 1.0 Schedule of Values, Item 10 “12” Pipe Installation – Roads and RR (Jack & Bore)”. The Bid Summary Form issued with Engineer’s Addendum No. 01 includes 12” Pipe Installation – Roads and RR (Jack & Bore) as Item 13. Please confirm that it is the intent of the clarification to be associated with Item 10.”* **A:** The intent of the clarification in Addendum 2 is to be associated with Item 13 on the Bid Summary Form issued with Addendum 1.
13. **Q:** *“Will a new bid form be issued prior to bid?”* **A:** Yes. Both a Bid Form and a Bid Summary Form are attached to this Addendum.
14. **Q:** *“Due to many different types of Silt Socks available on the market today, please provide a suggested manufacture make or model or provide a specification for the Silt Sock the Owner wishes the Contractor to use on this Project.”* **A:** For a good example, refer to Industrial Fabrics, Inc. (<http://www.industrialfabricsinc.com/gs-logs.php>)
15. **Q:** *“DWG. ANGP-EPSC 018 the wetlands table calls out wetland 2012-CM-143 from station 456+51 to 467+09 and on the alignment detail it is show to be at station 465+51 to 467+09. Please clarify which stationing is correct.”* **A:** 465+51 to 467+09 is correct.
16. **Q:** *“Please provide the physical address or location for the hydro testing water source.”* **A:** The hydrant on the corner of Severance Road and Hannah’s Place may be an option, as well as the hydrant on Mill Pond Road adjacent to the ROW. Contractor shall coordinate with the Construction Manager and the Champlain Water District prior to the hydrotest.
17. **Q:** *“Is there a schedule for the HDD’s being performed on the Transmission project?”* **A:** There is no current schedule; however, the schedule will be dependent on receiving applicable environmental permits. The HDD duration schedule at each site was included as an attachment to Addendum 1.
18. **Q:** *“The Blasting Plan for ANGP states on page 3 under Pre-Blast Surveys/Notification that “Pre-blast surveys will be conducted by a qualified firm approved by VGS. The CHA Project Manual on page 3 of Section 312316.26 under Submittals 1.4.C.2 states that ... the Independent Specialty Condition Survey Contractor shall conduct a post-blasting survey...Shouldn’t the same independent firm conduct both the pre and post blast surveys? The blast plan does not specify an “independent firm” as defined in the Project Manual.”* **A:** The same independent firm shall conduct the pre and post blast surveys.

19. **Q:** *“Under the Pre-Blast Surveys/Notification section in the Blast Plan the water quantity testing is not specified to be performed by a Vermont Licensed Well Driller as per the CHA Project Manual. The water quality testing should be conducted by an independent testing firm.”* **A:** Water quantity testing shall be performed by an independent licensed well driller. Water quality testing shall be performed by an independent testing firm.
20. **Q:** *“In the Project Manual on page 2 under Definitions 1.3.G there is an Independent Specialty Condition Seismic Survey Contractor defined as “A subcontractor approved by the Construction Manager...to perform seismic vibration monitoring on-site and off-site at locations specified or designated by the Construction Manager.” Are we to assume that the Seismic Monitoring and the Pre/post Blast Surveys will need to be performed by an independent subcontractor not an employee of the Blasting Contractor?”* **A:** The assumption is correct. An independent subcontractor shall perform seismic monitoring and pre/post blast surveys.
21. **Q:** *“Due to the sensitivity of some of the public to this project, I feel that everything should be done in the blasting portion to improve public relations with the neighbors within 600’ of the blasting.”* **A:** Blasting operation distances shall follow applicable Contract Documents (specifications, ANGP blasting plans, MOU’s, etc.).
22. **Q:** *“Which contract include the access road gates?”* **A:** Access road gates will be included with the Transmission Contract.
23. **Q:** *“Will all chain link fence, gates, poles, etc for the installation of the fence surrounding the Colchester Launcher site be provided by Contractor or Owner?”* **A:** Supplied by Owner.
24. **Q:** *“ESPC Drawings show Concrete Construction Barrier at station 616+00 on access road “J”. Can you please detail which type of barrier is to be used and where they are to be placed (along paved parking lot? entire length of access road?)”* **A:** Concrete “Jersey” barriers along the existing paved parking lot.
25. **Q:** *“Can you please supply us with the HDD bore sequence?”* **A:** The sequence has not yet been finalized. HDD durations were provided in Addendum 1.
26. **Q:** *“Note: Some of the Jack and Bores are called out as construction type # 9 (uncased) and some as # 10 (cased). Is the VTRANS AOT D-20 Standard going to apply when crossing State owned highways?”* **A:** State owned highway crossings shall be installed per the Site Specific Plans attached to the VTrans 1111 Permit Application.
27. **Q:** *“Is VGS to supply the casing for the # 10 design type crossing? (Assumption is that on the # 9 crossings VGS will be supplying pipe)”* **A:** Yes – Refer to Addison Natural Gas Project Scope of Work and Specifications, Item 32 “Material and Equipment Supplied by the Company”.
28. **Q:** *“What diameter casing will be used in the # 10 crossing locations?”* **A:** Construction Type 10 is for cased jack and bore applications. Casing sizes, type, spacers, and end seals are specified on site specific railroad crossing plans located on the project collaboration website.
29. **Q:** *“In the event of rejection is open cut going to be an option or will those type issues (should they occur) be evaluated individually as a change order?”* **A:** This will be evaluated, if necessary, on a case-by-case basis.
30. **Q:** *“At rail crossing located at station 112+76 it also shows an 8” crossing for future; when called for are the future casings included in this scope of work and if so is the casing being supplied by VGS?”* **A:** Casing pipes are supplied by VGS. 8-inch casing for future distribution is part of the Transmission Contractor’s scope – refer to Specification “Summary” 011000 issued with Addendum 1.
31. **Q:** *“With regard to technology what can be used for these crossings (#9 and #10 type) - (Jack & Bore with ABM, HDD, Pipe Ramming).”* **A:** Trenchless crossing technologies

are acceptable provided they meet the intent of the design and meet the conditions of the regulatory authorities having jurisdiction. Contractor shall submit on means and methods that differ from the existing design for Owner/Construction Manager review.

32. **Q:** “What size entry and exit pits will be allowed?” **A:** Per the alignment plans and site specific detail drawings.
33. **Q:** “Will there be room available at the lay down yard on Plank Road for the HDPE distribution piping? (DWG. ANGP – T – G – 023)” **A:** Yes - 1 acre.

PART IV – LIST OF ATTACHMENTS

1. ANGP Construction Conditions_131211 (This replaces the previously issued Construction Condition Line list).
2. ANGP_Project_Data_131211 KMZ (This replaces the previously issued Construction Condition Line list).
3. UNHSC Design Specifications for Porous Asphalt Pavement and Infiltration Beds
4. VTrans Standard E-119
5. Synopsis of Vermont Gas Systems, Inc. – Operator Qualification Plan
6. VGS Transmission Construction Contractor OQ List
7. VGS Transmission Construction Inspector OQ List
8. Bid Form – MS Word and PDF format.
9. Bid Summary Form – MS Word and PDF format.
10. Certified Copy of Resolution – MS Word and PDF format.
11. Bidder’s qualification questionnaire form – MS Word format.
12. Plans/Sketches:
 - a. ANGP-T-G-003-SK1
 - b. ANGP-T-G-007A-SK1
 - c. ANGP-T-G-008-SK1
 - d. ANGP-T-G-009-SK1
 - e. ANGP-T-G-015 Rev. 2
 - f. ANGP-T-G-022 Rev. 1
 - g. ANGP-T-C-013-SK1
 - h. ANGP-T-C-027 Rev. 2
 - i. ANGP-EPSC-027 Rev. 2
 - j. ANGP-T-C-040-SK1
 - k. ANGP-T-C-047-SK1
 - l. ANGP-T-C-067-SK1
 - m. ANGP-T-C-068-SK1

PART V – ADDITIONAL INFORMATION

1. None.

END OF ENGINEER’S ADDENDUM

Date: November 13, 2013

Submitted by: CHA

ENGINEER'S ADDENDUM NO. 04
TO THE BID DOCUMENTS (PLANS AND SPECIFICATIONS) FOR
Proposed System Expansion
Addison Natural Gas Project (ANGP)
Transmission Contract
November 26, 2013

The following changes and/or additions shall be made to the plans and/or specifications. All other requirements of the contract documents shall remain the same. Acknowledge receipt of this addendum by inserting its number and date in the Bid Proposal.

Changes/Additions to the Bid Documents:

THIS ADDENDUM is hereby made a part of the contract documents on the subject work as though originally included therein. The following amendments, additions and/or corrections shall govern this work.

This Addendum is in the following parts as follows:

- | | |
|----------|--|
| Part I | - Pertaining to Drawings |
| Part II | - Pertaining to Technical Specifications |
| Part III | - Clarifications to Contractor's Questions |
| Part IV | - List of Attachments |
| Part V | - Additional Information |

PART I - PERTAINING TO DRAWINGS

1. None.

PART II - PERTAINING TO TECHNICAL SPECIFICATIONS

1. None.

PART III – CLARIFICATIONS TO CONTRACTOR QUESTIONS

1. **Q:** "Please provide the anticipated quantity of hot bends that will be provided for the 12" Main Line." **A:** Approximately 179 bends. Provided bends will be segmentable.
2. **Q:** "Will foam be allowed for pipe supports and trench breakers in lieu of the specified sandbags?" **A:** Yes – foam is acceptable for trench breakers and pipe supports.
3. **Q:** "Per drawing ANGP-T-G-011, Construction EPSC Note 12, we are to use mats through the wetlands per the EPSC plan. The station footage called out for matting on the EPSC drawings is 30,304 LF. The matted station footage called out in the drawings far exceeds the 4,000 EA provided. The called out matted station footage does not include mats needed for the following:
 - a. Additional wetland footage as shown on the drawings

Add "Addendum 4"
to each footer.

- b. Mats needed for access roads within wetlands shown on drawings. The access road wetland stationing or footage is not called out on the drawings and is not part of the matting or wetland stationing callouts shown on the drawings.
- c. Ancillary mats referenced in various notes on drawing ANGP-T-G-011
- d. Mats called out in RTE Matting Table on sheet ANGP-T-G-015
- e. Mats associated with the stream crossings per Additional Environmental Note 10 on drawing ANGP-T-G-011. This only pertains to stream crossing stationing that fall outside of the called out matting stationing. Most of the stream crossings will require mats longer than 16 FT and thicker than 8" to construct bridges.
- f. Other mats that will be needed due to working in the expected weather conditions. Per the last 10 years' worth of precipitation data from the closest NOAA weather data center (Burlington), the project location will average 4.87 inches of rainfall per month from May to October.

A: Refer to Addendum 3, Part III, Question/Answer #2.

4. **Q:** "Please provide a pipe delivery schedule. Please include the number of trucks or rail cars expected per day, number of pieces expected per truck or rail car, the number of work days the trucks or rail cars will be available for offloading, the expected pickup location and the anticipated start date for this work." **A:** Pipe delivery schedule is being finalized and will be coordinated with selected contractor. Owner intends to contract with Northeast Freight Transfer (NFT) for delivery and scheduling of loads. For bidding purposes, the following apply:

- a. **ARO coated pipe** – initial pipe deliveries scheduled for mid-January 2014. All pipe will be delivered to the staging area in Swanton, VT and offloaded from rail cars by NFT. All staging area preparation and maintenance will be by NFT. There is adequate space for all ARO pipe to be staged at this site. **Contractor is responsible for loading their own trucks for stringing from Swanton.** The Contractor is free to contract with NFT for pipe loading in Swanton. The contact person is Tom Coleman, 732-299-7321, t_coleman@nefreightrasnfer.com
- b. **FBE Coated Pipe** – initial pipe deliveries are scheduled for mid-March 2014. All pipe will be delivered to the Contractor staging yard in Williston, VT (all site preparation by Contractor) and offloaded by NFT. Contractor will assume responsibility for pipe after offloading by NFT. Current expectations are 4 trucks/day when deliveries of FBE coated pipe begin. Induction bends will also be delivered to the Williston site and offloaded by NFT.
- c. **Pritec Coated Pipe** – initial pipe deliveries are scheduled for mid-March 2014. The entirety of Pritec coated pipe will be initially staged at the coating facility in Morrisville, PA while delivery to VT is coordinated. NFT will prepare a rail offloading and staging yard in New Haven Junction, VT behind the Phoenix Feeds facility (coordinates 44.127937, -73.184009). ~ 20,000 ft of pipe will be staged at this site with another ~ 20,000 ft on rail cars in Middlebury, VT. Stock at the staging facility will be replenished from the rail cars and the rail cars will be replenished from the coating facility as necessary. **NFT will prep the site, maintain a job trailer, two excavators with vacuum pipe lifters, and management/labor staff at this site for maintaining stock and loading of Contractor trailers for stringing.** Contractor

will provide adequate trailers allowing NFT to pre-load for stringing operations. Contractor to bring in an empty trailer and swap for a loaded one while conducting stringing operations. Contractor will assume responsibility for pipe after it is loaded onto Contractor Trailers.

5. **Q:** *“Please provide a construction mat delivery schedule. Please include the number of trucks expected per day, number of pieces expected per truck, the number of days expected to complete delivery and the expected start date for delivery.”* **A:** Mat delivery schedule will be coordinated with the selected contractor. This will dictate the trucks/day and number of days over which the mats will be delivered. 18-20 mats/truck is the anticipated load size.
6. **Q:** *“With the exception of the I89 and Plank road HDD crossing, will the Contractor be allowed to access the ROW from all other public jack & bore and/or HDD road crossings?”* **A:** Yes – the contractor shall coordinate with the Construction Manager and the local authorities at these locations. Contractor will be responsible for any transportation permits.
7. **Q:** *“Is the Owner paying the landowners to restore the golf courses from station 490+00 to 512+00 and 894+00 to 910+00? If the contractor is to include the restoration in the bid, please provide scope.”* **A:** Yes – golf course owners will restore disturbed areas. Contractor shall backfill trench, then rough grade right-of-way to match existing grades. 6-inches of topsoil and mulch or RECP shall be installed by contractor.
8. **Q:** *“Can the Owner acquire the existing road at station 1816+75 to be used as a temporary access road?”* **A:** This will be further reviewed with the Owner, however for bidding purposes, Contractors shall utilize the access roads that have already been obtained and detailed in the drawings.
9. **Q:** *“Table 8 on drawing ANGP-T-G-017 provides useful information for 9 EA of the 43 EA total open cut streams. Please provide this info for the remaining 34 EA streams. Anticipated flow rate (CFS) would also be helpful.”* **A:** The open cut stream information on ANGP-T-G-017 is for streams that are under jurisdiction of the Vermont Agency of Natural Resources (ANR). Many other “streams” are small in comparison and do not fall under the jurisdiction of ANR.
10. **Q:** *Is there information available that clarifies which of the two open cut stream crossing methods on drawing ANGP-T-G-020 will apply to each stream crossing on the alignment?* **A:** The two open cut stream crossing methods shown are two potential arrangements. Means and methods of open cut stream crossings are the responsibility of the contractor, however, means and methods shall follow applicable permitting conditions/regulations.
11. **Q:** *“Please provide a defined scope for the Contractor to price the HDD support item. A defined scope will help the Engineer/Owner get a better price comparison for that bid item.”* **A:** Refer to Specification 012300 “Alternates” Item 3.1.B – issued as an attachment to Addendum 1.
12. **Q:** *“Please reference drawing ANGP-T-G-011, Additional Environmental Note 11. This note indicates the Top Of Bank stationing is provided on the drawings. After calculating the stationing provided in stream bar on the ESPC plans, it appears the distance between stream banks can be quite long. Construction detail 4 on drawing ANGP-T-G-019 bridges to be positioned to the top of the stream banks. Please verify the stationing in the stream bar is from top of bank to top of bank. If this stationing is not top of bank to top of bank, please provide that information for each stream crossing or the length of bridge or matting*

to be used for each crossing.” A: Correct. The distance from top of bank to top of bank can be quite long. An attempt to check every stream station has not been completed for this Addendum. If there are incorrect stations on the drawings, they will be addressed during the construction phase. For stream crossings with longer distances, intermittent supports between mats is acceptable per Construction Detail 4 on Drawing ANGP-T-G-019.

13. **Q:** *“Please provide the location, depth and size of any drain tile located within the construction limits.”* **A:** This information is unknown.

14. **Q:** *“Will the Owner allow the use of CDF or Flow Fill for backfilling the open cut roads?”* **A:** Yes.

15. **Q:** *“Can the Owner acquire more acreage at the Williston and Plank Road construction yards? We will need 8 to 10 acres just for our operations, employee parking, offices, equipment maintenance, misc material storage, fuel system, etc.”* **A:** Contractors shall bid the project according to the available pipe yards and laydown areas detailed in the plans. If additional area is required, the contractor may submit to the Construction Manager and Vermont Gas for review. Additional areas must be reviewed by appropriate regulatory agencies.

16. **Q:** *“Please provide the pipeline stations that state patrol cars will be required for additional traffic control support.”* **A:** Typically, Town Police Departments will provide patrol cars/officers for traffic control support when required/requested by the Owner or permitting conditions. Exact stations and locations are not known at this time. If traffic control measures directed by Police are required/requested by permitting conditions or the Owner, the Towns will bill the Owner directly for their services.

PART IV – LIST OF ATTACHMENTS

1. None.

PART V – ADDITIONAL INFORMATION

1. None.

END OF ENGINEER’S ADDENDUM

Date: November 26, 2013
Submitted by: CHA

ENGINEER'S POST-BID BULLETIN NO. 04
TO THE BID DOCUMENTS (PLANS AND SPECIFICATIONS) FOR
Proposed System Expansion
Addison Natural Gas Project (ANGP)
Transmission Contract
April 1, 2014

Move PBB4 to after
PBB3

The following changes and/or additions shall be made to the plans and/or specifications. All other requirements of the contract documents shall remain the same.

Changes/Additions to the Bid Documents:

THIS POST-BID BULLETIN is hereby made a part of the contract documents on the subject work as though originally included therein. The following amendments, additions and/or corrections shall govern this work.

This Bulletin includes the following parts as follows:

- Part I - Pertaining to Drawings
- Part II - Pertaining to Technical Specifications
- Part III - Clarifications to Contractor's Questions
- Part IV - List of Attachments
- Part V - Additional Information

PART I - PERTAINING TO DRAWINGS

1. None.

PART II - PERTAINING TO TECHNICAL SPECIFICATIONS

1. Specification 015000, Part 2.2.N.1: **REVISE** the first sentence from "...mid-size 400 Series ATV's..." to read "...mid-size 400 Ranger Series UTV's..."
2. The permits to open streets or rights of way issued by the Town of Essex are hereby issued and all conditions stated shall apply.
3. The NPDES updated draft permit has been issued by the Vermont Agency of Natural Resources and all conditions stated shall apply. This updated draft permit shall supersede the NPDES draft permit issued with Post Bid Bulletin No. 1.
4. The Agency of Natural Resources Draft Water Quality Certification is hereby issued and all conditions stated shall apply.

PART III – CLARIFICATIONS TO CONTRACTOR QUESTIONS

1. On-site Plan Coordinator: In Addendum 2 (Question 6), the Contractor was given clarification that the On-site Plan Coordinators (OSPC) would be provided by VGS. **REVISE this response – All OSPC tasks and responsibilities will be provided by the Contractor.** Information regarding OSPC tasks and responsibilities was provided in Post Bid Bulletin 1 (Draft Discharge Permit – 6949-INDC) as well as on Sheet ANGP-T-G-011 in the EPSC Drawings. Additionally,

the OSPC's must be approved by the Vermont Agency of Natural Resources, Department of Environmental Conservation (DEC) prior to beginning work. The Contractor shall provide general qualifications and contact information for each potential OSPC with adequate time for DEC review/approval.

PART IV – LIST OF ATTACHMENTS

1. Vermont Agency of Natural Resources - Draft Discharge Permit NPDES Number: VTS0000146
2. Vermont Agency of Natural Resources – Draft Water Quality Certification
3. Town of Essex Permits dated 10/11/13 and numbered 1 through 10.

PART V – ADDITIONAL INFORMATION

1. None.

END OF POST BID BULLETIN NO. 4

DRAFT - NOT FOR CONSTRUCTION

- ii. BLUE available August 1, 2014
- iii. YELLOW Re-evaluate August 1, 2014
- d. Contingency Plan
 - i. YELLOW ROW not available (or some portion thereof)
 - 1. Winter shutdown and maintenance of the EPSC if required
 - 2. In service date August 1, 2015

PART III – CLARIFICATIONS TO CONTRACTOR QUESTIONS

- 1. None.

PART IV – LIST OF ATTACHMENTS

- 1. Certificate of Public Good, Docket No. 7970 dated 12/23/2013.
- 2. Town of Colchester building permit No. 23647.
- 3. Town of Williston Public Works street permits numbered 239-13, 12-13-13, 241-13, 242-13, and 243-13
- 4. Draft Discharge Permit NPDES Number: VTS0000146
- 5. US ACOE 404 Wetland Permit Public Notice File Number: NAE-2012-0123
- 6. ANGP ROW Projection dated January 13, 2014 – CONFIDENTIAL

PART V – ADDITIONAL INFORMATION

- 1. None

DRAFT - NOT FOR CONSTRUCTION

ENGINEER'S POST-BID BULLETIN NO. 02
TO THE BID DOCUMENTS (PLANS AND SPECIFICATIONS) FOR
Proposed System Expansion
Addison Natural Gas Project (ANGP)
Transmission Contract
January 16, 2013

The following changes and/or additions shall be made to the plans and/or specifications. All other requirements of the contract documents shall remain the same.

Changes/Additions to the Bid Documents:

THIS POST-BID BULLETIN is hereby made a part of the contract documents on the subject work as though originally included therein. The following amendments, additions and/or corrections shall govern this work.

This Bulletin includes the following parts as follows:

- Part I - Pertaining to Drawings
- Part II - Pertaining to Technical Specifications
- Part III - Clarifications to Contractor's Questions
- Part IV - List of Attachments
- Part V - Additional Information

PART I - PERTAINING TO DRAWINGS

1. None.

PART II - PERTAINING TO TECHNICAL SPECIFICATIONS

1. Provide a formal response regarding any bid price adjustments associated with PBB-1 and PBB-2 no later than Wednesday January 22, 2014. Price adjustments are to be listed individually with sufficient detail for Owner review.
2. The Contractor response shall incorporate both the target completion date of December 1, 2014 and the contingency completion date of August 1, 2015.
3. Contractor to provide alternate cost pricing for any potential savings as discussed at the PBB-1 review meeting. Cost reduction options will be kept in confidence.
4. Scope of Work and Specifications (narrative spec), Section 32, Material and Equipment Supplied by the Company, Paragraph I, Other Company Supplied Material, sub-paragraph L.
 - a. Change 4,000 timber mats to ~2,300 mats.
5. Section 011000, 1.5 Owner-Furnished Products, A, 3.
 - a. Change 4,000 timber mats to ~ 2,300 Timber Mats
6. Contractor to provide unit price for additional mats (\$/mat) FOB job site. The Contract amount will be adjusted by unit price to compensate Contractor for the difference in Owner supplied mats as described in the original bid specification.

Add "PBB2" to
each footer

PART III – CLARIFICATIONS TO CONTRACTOR QUESTIONS

1. None.

PART IV – LIST OF ATTACHMENTS

1. None

PART V – ADDITIONAL INFORMATION

1. None

DRAFT - NOT FOR CONSTRUCTION

ENGINEER'S POST-BID BULLETIN NO. 03
TO THE BID DOCUMENTS (PLANS AND SPECIFICATIONS) FOR
Proposed System Expansion
Addison Natural Gas Project (ANGP)
Transmission Contract
February 14, 2014

The following changes and/or additions shall be made to the plans and/or specifications. All other requirements of the contract documents shall remain the same.

Changes/Additions to the Bid Documents:

THIS POST-BID BULLETIN is hereby made a part of the contract documents on the subject work as though originally included therein. The following amendments, additions and/or corrections shall govern this work.

This Bulletin includes the following parts as follows:

- Part I - Pertaining to Drawings
- Part II - Pertaining to Technical Specifications
- Part III - Clarifications to Contractor's Questions
- Part IV - List of Attachments
- Part V - Requested Contractor Information

PART I - PERTAINING TO DRAWINGS

1. REPLACE the following sheets with the attached sheets:
 - a. ANGP-T-C-035 (Rocky Ridge/LL93 Reroute)
 - b. ANGP-EPSC-035 (Rocky Ridge/LL93 Reroute)
 - c. ANGP-T-C-044 (LL 116 Reroute)
 - d. ANGP-EPSC-044 (LL 116 Reroute)
 - e. ANGP-T-C-050 (Palmer Reroute)
 - f. ANGP-T-C-051 (Palmer Reroute)
 - g. ANGP-EPSC-050 (Palmer Reroute)
 - h. ANGP-EPSC-051 (Palmer Reroute)
 - i. ANGP-T-C-061B (Old Stage Road Reroute)
 - j. ANGP-T-C-62 (Old Stage Road Reroute)
 - k. ANGP-EPSC-061B (Old Stage Road Reroute)
 - l. ANGP-EPSC-62 (Old Stage Road Reroute)
2. REVISE the following sheets with the minor details provided below. A construction issued drawing set will be issued prior to mobilization incorporating all drawing changes to date.
 - a. ANGP-T-G-007A, ANGP-T-C-033, ANGP-T-C-034, ANGP-EPSC-033, ANGP-EPSC-034: Delete Access Road "AL"
 - b. ANGP-T-C-029, ANGP-EPSC-029: Move ATWS (50'x130') from east side of alignment to west side of alignment.
 - c. ANGP-T-G-010, ANGP-T-C-056, ANGP-EPSC-056: Shorten ATWS (north side) to match limits of access road "AC"

Add "PBB3" to
each footer

- d. ANGP-T-G-007B: Move Access Road AN from west side of right of way to east side of right of way

PART II - PERTAINING TO TECHNICAL SPECIFICATIONS

1. REVISED Contractual Dates and Milestones:
 - a. Pre-mobilization: Schedule is contractor convenience after rights are secured by Owner. Pre-mobilization will include the use of the stabilized gravel parking area at the Williston Pipe Yard. Earth disturbance for constructing the remainder of the pipe yard cannot begin until the Mobilization date below.
 - b. Mobilization: May 15, 2014 – best available estimate at this time.
 - c. Substantial Completion:
 - i. 0+00 to 551+13 (Colchester Tie-in to Williston M&R) – December 1, 2014
 - ii. 1718+20 to 2179+88 (Plank Road M&R to Middlebury M&R) – December 1, 2014
 - iii. 551+13 to 1718+13 (Williston M&R to Plank Road M&R) – July 1, 2015
 - iv. Rocky Ridge Golf Course/Line List Property 93 (Approx. Sta. 893+60 to 910+65) – work commence after October 31, 2014, complete November 15, 2014. Contractor to restore site to rough grade. Final restoration to be completed by Owner.
 - d. Final Completion: 0+00 to 2179+88 (entire Transmission Main) – August 1, 2015
2. REVISED pipe/materials and transportation logistics. The plan below will supersede both the scope of work defined in the Project Manual and subsequent Addendums.
 - a. ARO pipe – ARO pipe shall be delivered to Swanton, VT by May 1, 2014 (not included in Transmission Contract Scope of Work). The Transmission Contractor scope of work shall include loading and transportation for pipe stringing operations. The use of a vacuum lift system is required for handling all pipe – slings and/or chains will not be acceptable.
 - b. FBE pipe – FBE pipe shall be delivered to the Williston Pipe yard beginning on May 15, 2014. The FBE pipe will be trucked on an “as needed basis” from Pennsylvania. Upon delivery, the Transmission Contractor shall unload and stack pipe in the pipe yard. The Transmission Contractor will load and transport the pipe from the pipe yard to the right-of-way as needed. The use of a vacuum lift system is required for handling all pipe – slings and/or chains will not be acceptable.
 - c. Pritec pipe – Pritec pipe shall be delivered to the Williston Pipe yard beginning on May 15, 2014. The Pritec pipe will be trucked on an “as needed basis” from Pennsylvania. Upon delivery, the Transmission Contractor shall unload and stack pipe in the pipe yard. The Transmission Contractor will load and transport the pipe from the pipe yard to the right-of-way as needed. The use of a vacuum lift system is required for handling all pipe – slings and/or chains will not be acceptable.
 - d. All other required transmission main materials – Owner shall deliver materials to the Williston or Plank Road pipe yards. Contractor shall unload and store materials at the pipe yard.
3. REVISED mat plan. The plan below will supersede both the scope of work defined in the Project Manual and subsequent Addendums.

- a. ~2,300 mats (final mat count to be determined) will be available on June 1, 2014 in St. Albans, Vermont. Contractor shall include transportation of mats from St. Albans to the Williston and/or Plank Road. Mats will be washed prior to the Transmission Contractor arriving and is not included in this contract.

PART III – CLARIFICATIONS TO CONTRACTOR QUESTIONS

1. None.

PART IV – LIST OF ATTACHMENTS

1. Drawings noted in PART I.

PART V – REQUESTED CONTRACTOR INFORMATION

1. Provide a formal response regarding any bid price adjustments associated with PBB-3 no later than Friday, February 21, 2014. Price adjustments are to be listed individually with sufficient detail for Owner review.
2. Contractor shall provide cost savings associated with substituting pipe pillows with sandbags.
3. Contractor shall provide cost savings associated with utilizing sand bedding or rockshield.
4. Contractor shall provide their standard insurance certificate (\$2M General Liability, \$5M Umbrella) for Owner review.
5. Contractor shall provide two option prices.
 - a. Contractor shall utilize ARK Technical Services to install all AC Mitigation and Cathodic Protection measures within the scope of work included in the Transmission Contract.
 - b. Contractor deduct price for AC mitigation and CP with no excavation or backfill support required.

END OF POST BID BULLETIN 3

DRAFT - NOT FOR CONSTRUCTION

DRAFT - NOT FOR CONSTRUCTION



Vermont Gas Systems, Inc.

OPERATIONS & MAINTENANCE MANUAL Abridged Version for Transmission Construction Contractors

2013

Add footer VGS
O&M Manual Page
x of y

Uncontrolled Copy

Code Section – Table of Contents

192E	Welding of Steel in Pipelines
192G	General Construction Requirements for Transmission Lines and Mains
192I	Requirements for Corrosion Control
192J	Test Requirements

DRAFT - NOT FOR CONSTRUCTION

VGS Operations & Maintenance Manual	Minimum Federal Safety Standards Subpart E – Welding of Steel in Pipelines Part 192.221 Scope Effective Date: March 31, 2009 Page 1 of 1
--	---

- (a) This subpart prescribes minimum requirements for welding steel materials in pipelines.
- (b) This subpart does not apply to welding that occurs during the manufacture of steel pipe or steel pipeline components.

DRAFT - NOT FOR CONSTRUCTION

VGS Operations & Maintenance Manual	Minimum Federal Safety Standards Subpart E – Welding of Steel in Pipelines Part 192.225 Welding Procedures Effective Date: March 31, 2009 Page 1 of 1
--	--

(a) Welding must be performed by a qualified welder in accordance with welding procedures qualified under section 5 of API 1104 (incorporated by reference, see §192.7) or section IX of the ASME Boiler and Pressure Vessel Code “Welding and Brazing Qualifications” (incorporated by reference, see §192.7) to produce welds meeting the requirements of this subpart. The quality of the test welds used to qualify welding procedures shall be determined by destructive testing in accordance with the applicable welding standard(s).

(b) Each welding procedure must be recorded in detail, including the results of the qualifying tests. This record must be retained and followed whenever the procedure is used.

[Amdt. 192–52, 51 FR 20297, June 4, 1986; Amdt. 192–94, 69 FR 32894, June 14, 2004]

***See following procedure:
Welding***

DRAFT - NOT FOR CONSTRUCTION

VGS Operations & Maintenance Manual	Minimum Federal Safety Standards Subpart E – Welding of Steel in Pipelines Part 192.227 Qualification of Welders Effective Date: March 31, 2009 Page 1 of 1
--	--

(a) Except as provided in paragraph (b) of this section, each welder must be qualified in accordance with section 6 of API 1104 (incorporated by reference, see §192.7) or section IX of the ASME Boiler and Pressure Vessel Code (incorporated by reference, see §192.7). However, a welder qualified under an earlier edition than listed in §192.7 of this part may weld but may not requalify under that earlier edition.

(b) A welder may qualify to perform welding on pipe to be operated at a pressure that produces a hoop stress of less than 20 percent of SMYS by performing an acceptable test weld, for the process to be used, under the test set forth in section I of Appendix C of this part. Each welder who is to make a welded service line connection to a main must first perform an acceptable test weld under section II of Appendix C of this part as a requirement of the qualifying test.

[35 FR 13257, Aug. 19, 1970, as amended by Amdt. 192–43, 47 FR 46851, Oct. 21, 1982; Amdt. 192–52, 51 FR 20297, June 4, 1986; Amdt. 192–78, 61 FR 28784, June 6, 1996; Amdt. 192–94, 69 FR 32894, June 14, 2004; Amdt. 192–103, 72 FR 4656, Feb. 1, 2007]

See following procedure:

Welding

DRAFT - NOT FOR CONSTRUCTION

**VGS Operations
&
Maintenance
Manual**

**Minimum Federal Safety Standards
Subpart E – Welding of Steel in Pipelines
Part 192.229
Limitations on Welders
Effective Date: March 31, 2009
Page 1 of 1**

(a) No welder whose qualification is based on nondestructive testing may weld compressor station pipe and components.

(b) No welder may weld with a particular welding process unless, within the preceding 6 calendar months, he has engaged in welding with that process.

(c) A welder qualified under §192.227(a)—

(1) May not weld on pipe to be operated at a pressure that produces a hoop stress of 20 percent or more of SMYS unless within the preceding 6 calendar months the welder has had one weld tested and found acceptable under the sections 6 or 9 of API Standard 1104 (incorporated by reference, see §192.7). Alternatively, welders may maintain an ongoing qualification status by performing welds tested and found acceptable under the above acceptance criteria at least twice each calendar year, but at intervals not exceeding 71/2months. A welder qualified under an earlier edition of a standard listed in §192.7 of this part may weld but may not requalify under that earlier edition; and

(2) May not weld on pipe to be operated at a pressure that produces a hoop stress of less than 20 percent of SMYS unless the welder is tested in accordance with paragraph (c)(1) of this section or requalifies under paragraph (d)(1) or (d)(2) of this section.

(d) A welder qualified under §192.227(b) may not weld unless—

(1) Within the preceding 15 calendar months, but at least once each calendar year, the welder has requalified under §192.227(b); or

(2) Within the preceding 71/2calendar months, but at least twice each calendar year, the welder has had—

(i) A production weld cut out, tested, and found acceptable in accordance with the qualifying test; or

(ii) For welders who work only on service lines 2 inches (51 millimeters) or smaller in diameter, two sample welds tested and found acceptable in accordance with the test in section III of Appendix C of this part.

[35 FR 13257, Aug. 19, 1970, as amended by Amdt. 192–37, 46 FR 10159, Feb. 2, 1981; Amdt. 192–78, 61 FR 28784, June 6, 1996; Amdt. 192–85, 63 FR 37503, July 13, 1998; Amdt. 192–94, 69 FR 32895, June 14, 2004]

***See following procedure:
Welding***

VGS Operations & Maintenance Manual	Minimum Federal Safety Standards Subpart E – Welding of Steel in Pipelines Part 192.231 Protection from Weather Effective Date: March 31, 2009 Page 1 of 1
--	---

The welding operation must be protected from weather conditions that would impair the quality of the completed weld.

See following procedure:

Welding

DRAFT - NOT FOR CONSTRUCTION

VGS Operations & Maintenance Manual	Minimum Federal Safety Standards Subpart E – Welding of Steel in Pipelines Part 192.233 Miter Joints Effective Date: March 31, 2009 Page 1 of 1
--	--

(a) A miter joint on steel pipe to be operated at a pressure that produces a hoop stress of 30 percent or more of SMYS may not deflect the pipe more than 3°.

(b) A miter joint on steel pipe to be operated at a pressure that produces a hoop stress of less than 30 percent, but more than 10 percent, of SMYS may not deflect the pipe more than 12 1/2° and must be a distance equal to one pipe diameter or more away from any other miter joint, as measured from the crotch of each joint.

(c) A miter joint on steel pipe to be operated at a pressure that produces a hoop stress of 10 percent or less of SMYS may not deflect the pipe more than 90°.

***See following procedure:
Welding***

DRAFT - NOT FOR CONSTRUCTION

VGS Operations & Maintenance Manual	Minimum Federal Safety Standards Subpart E – Welding of Steel in Pipelines Part 192.235 Preparation for Welding Effective Date: March 31, 2009 Page 1 of 1
--	---

Before beginning any welding, the welding surfaces must be clean and free of any material that may be detrimental to the weld, and the pipe or component must be aligned to provide the most favorable condition for depositing the root bead. This alignment must be preserved while the root bead is being deposited.

*See following procedure:
Welding*

DRAFT - NOT FOR CONSTRUCTION

(a) Visual inspection of welding must be conducted by an individual qualified by appropriate training and experience to ensure that:

- (1) The welding is performed in accordance with the welding procedure; and
- (2) The weld is acceptable under paragraph (c) of this section.

(b) The welds on a pipeline to be operated at a pressure that produces a hoop stress of 20 percent or more of SMYS must be nondestructively tested in accordance with §192.243, except that welds that are visually inspected and approved by a qualified welding inspector need not be nondestructively tested if:

- (1) The pipe has a nominal diameter of less than 6 inches (152 millimeters); or
- (2) The pipeline is to be operated at a pressure that produces a hoop stress of less than 40 percent of SMYS and the welds are so limited in number that nondestructive testing is impractical.

(c) The acceptability of a weld that is nondestructively tested or visually inspected is determined according to the standards in Section 9 of API Standard 1104 (incorporated by reference, see §192.7). However, if a girth weld is unacceptable under those standards for a reason other than a crack, and if Appendix A to API 1104 applies to the weld, the acceptability of the weld may be further determined under that appendix.

[35 FR 13257, Aug. 19, 1970, as amended by Amdt. 192–37, 46 FR 10160, Feb. 2, 1981; Amdt. 192–78, 61 FR 28784, June 6, 1996; Amdt. 192–85, 63 FR 37503, July 13, 1998; Amdt. 192–94, 69 FR 32894, June 14, 2004]

***See following procedure:
Welding***

**VGS Operations
&
Maintenance
Manual**

**Minimum Federal Safety Standards
Subpart E – Welding of Steel in Pipelines
Part 192.243
Nondestructive Testing
Effective Date: March 31, 2009
Page 1 of 1**

(a) Nondestructive testing of welds must be performed by any process, other than trepanning, that will clearly indicate defects that may affect the integrity of the weld.

(b) Nondestructive testing of welds must be performed:

(1) In accordance with written procedures; and

(2) By persons who have been trained and qualified in the established procedures and with the equipment employed in testing.

(c) Procedures must be established for the proper interpretation of each nondestructive test of a weld to ensure the acceptability of the weld under §192.241(c).

(d) When nondestructive testing is required under §192.241(b), the following percentages of each day's field butt welds, selected at random by the operator, must be nondestructively tested over their entire circumference:

(1) In Class 1 locations, except offshore, at least 10 percent.

(2) In Class 2 locations, at least 15 percent.

(3) In Class 3 and Class 4 locations, at crossings of major or navigable rivers, offshore, and within railroad or public highway rights-of-way, including tunnels, bridges, and overhead road crossings, 100 percent unless impracticable, in which case at least 90 percent. Nondestructive testing must be impracticable for each girth weld not tested.

(4) At pipeline tie-ins, including tie-ins of replacement sections, 100 percent.

(e) Except for a welder whose work is isolated from the principal welding activity, a sample of each welder's work for each day must be nondestructively tested, when nondestructive testing is required under §192.241(b).

(f) When nondestructive testing is required under §192.241(b), each operator must retain, for the life of the pipeline, a record showing by milepost, engineering station, or by geographic feature, the number of girth welds made, the number nondestructively tested, the number rejected, and the disposition of the rejects.

[35 FR 13257, Aug. 19, 1970, as amended by Amdt. 192-27, 41 FR 34606, Aug. 16, 1976; Amdt. 192-50, 50 FR 37192, Sept. 12, 1985; Amdt. 192-78, 61 FR 28784, June 6, 1996]

***See following procedure:
Welding***

VGS Operations & Maintenance Manual	Minimum Federal Safety Standards Subpart E – Welding of Steel in Pipelines Part 192.245 Repair or Removal of Defects Effective Date: March 31, 2009 Page 1 of 1
--	--

(a) Each weld that is unacceptable under §192.241(c) must be removed or repaired. Except for welds on an offshore pipeline being installed from a pipeline vessel, a weld must be removed if it has a crack that is more than 8 percent of the weld length.

(b) Each weld that is repaired must have the defect removed down to sound metal and the segment to be repaired must be preheated if conditions exist which would adversely affect the quality of the weld repair. After repair, the segment of the weld that was repaired must be inspected to ensure its acceptability.

(c) Repair of a crack, or of any defect in a previously repaired area must be in accordance with written weld repair procedures that have been qualified under §192.225. Repair procedures must provide that the minimum mechanical properties specified for the welding procedure used to make the original weld are met upon completion of the final weld repair.

[Amdt. 192–46, 48 FR 48674, Oct. 20, 1983]

***See following procedure:
Welding***

DRAFT - NOT FOR CONSTRUCTION

VGS Operations & Maintenance Manual	Minimum Federal Safety Standards Subpart G – General Construction Requirements for Transmission Lines and Mains Part 192.301 Scope Effective Date: March 31, 2009 Page 1 of 1
--	--

This subpart prescribes minimum requirements for constructing transmission lines and mains.

DRAFT - NOT FOR CONSTRUCTION

VGS Operations & Maintenance Manual	Minimum Federal Safety Standards Subpart G – General Construction Requirements for Transmission Lines and Mains Part 192.303 Compliance with Specifications or Standards Effective Date: July 31, 2009 Page 1 of 1
--	---

Each transmission line or main must be constructed in accordance with comprehensive written specifications or standards that are consistent with this part.

VGS - VGS personnel will comply with applicable sections of CFR Part 192 - Pipeline Safety Regulations, VGS Operating and Maintenance Procedures, VGS Engineering Standards, VGS Safety Standards, VGS Field Services Manual and VGS Emergency Plans while constructing and working on VGS pipeline systems.

See the following procedures:

Backfilling

Blasting

Boring

Branch Connections

Clean-up, Paving and Maintenance

End Points

Excavation and Trenches

Fittings

Horizontal Directional Drilling

Locator Wire

Permits, Easements and Rights of Way

Pigging

Pipe Installation

Purging

Records

Route Planning, Layout and Marking

Test Requirements

Tie-Ins

Valves

VGS Operations & Maintenance Manual	Minimum Federal Safety Standards Subpart G – General Construction Requirements for Transmission Lines and Mains Part 192.305 Inspection: General Effective Date: March 31, 2009 Page 1 of 1
--	--

Each transmission line or main must be inspected to ensure that it is constructed in accordance with this part.

VGS - Pipelines under construction shall be inspected, either by VGS personnel or designated contractors, to assure that all applicable construction standards have been followed.

DRAFT - NOT FOR CONSTRUCTION

VGS Operations & Maintenance Manual	Minimum Federal Safety Standards Subpart G – General Construction Requirements for Transmission Lines and Mains Part 192.307 Inspection of Materials Effective Date: March 31, 2009 Page 1 of 1
--	--

Each length of pipe and each other component must be visually inspected at the site of installation to ensure that it has not sustained any visually determinable damage that could impair its serviceability.

See following procedure:

Inspection

DRAFT - NOT FOR CONSTRUCTION

**VGS Operations
&
Maintenance
Manual**

**Minimum Federal Safety Standards
Subpart G – General Construction Requirements for
Transmission Lines and Mains
Part 192.309
Repair of Steel Pipe
Effective Date: March 31, 2009
Page 1 of 1**

(a) Each imperfection or damage that impairs the serviceability of a length of steel pipe must be repaired or removed. If a repair is made by grinding, the remaining wall thickness must at least be equal to either:

- (1) The minimum thickness required by the tolerances in the specification to which the pipe was manufactured;
or
- (2) The nominal wall thickness required for the design pressure of the pipeline.

(b) Each of the following dents must be removed from steel pipe to be operated at a pressure that produces a hoop stress of 20 percent, or more, of SMYS, unless the dent is repaired by a method that reliable engineering tests and analyses show can permanently restore the serviceability of the pipe:

- (1) A dent that contains a stress concentrator such as a scratch, gouge, groove, or arc burn.
- (2) A dent that affects the longitudinal weld or a circumferential weld.
- (3) In pipe to be operated at a pressure that produces a hoop stress of 40 percent or more of SMYS, a dent that has a depth of:
 - (i) More than 1/4 inch (6.4 millimeters) in pipe 1 23/4 inches (324 millimeters) or less in outer diameter;
or
 - (ii) More than 2 percent of the nominal pipe diameter in pipe over 1 23/4 inches (324 millimeters) in outer diameter.

For the purpose of this section a "dent" is a depression that produces a gross disturbance in the curvature of the pipe wall without reducing the pipe-wall thickness. The depth of a dent is measured as the gap between the lowest point of the dent and a prolongation of the original contour of the pipe.

(c) Each arc burn on steel pipe to be operated at a pressure that produces a hoop stress of 40 percent, or more, of SMYS must be repaired or removed. If a repair is made by grinding, the arc burn must be completely removed and the remaining wall thickness must be at least equal to either:

- (1) The minimum wall thickness required by the tolerances in the specification to which the pipe was manufactured; or
- (2) The nominal wall thickness required for the design pressure of the pipeline.

(d) A gouge, groove, arc burn, or dent may not be repaired by insert patching or by pounding out.

(e) Each gouge, groove, arc burn, or dent that is removed from a length of pipe must be removed by cutting out the damaged portion as a cylinder.

[35 FR 13257, Aug. 19, 1970, as amended by Amdt. 192-1, 35 FR 17660, Nov. 17, 1970; Amdt. 192-85, 63 FR 37503, July 13, 1998; Amdt. 192-88, 64 FR 69664, Dec. 14, 1999]

See following procedures:

Repairs – Steel pipe

Welding

VGS Operations & Maintenance Manual	Minimum Federal Safety Standards Subpart G – General Construction Requirements for Transmission Lines and Mains Part 192.311 Repair of Plastic Pipe Effective Date: March 31, 2009 Page 1 of 1
--	---

Each imperfection or damage that would impair the serviceability of plastic pipe must be repaired or removed.

[Amdt. 192–93, 68 FR 53900, Sept. 15, 2003]

See following procedures:

Repairs – Plastic Pipe

DRAFT - NOT FOR CONSTRUCTION

**VGS Operations
&
Maintenance
Manual**

**Minimum Federal Safety Standards
Subpart G – General Construction Requirements for
Transmission Lines and Mains
Part 192.313
Bends and Elbows
Effective Date: March 31, 2009
Page 1 of 1**

(a) Each field bend in steel pipe, other than a wrinkle bend made in accordance with §192.315, must comply with the following:

(1) A bend must not impair the serviceability of the pipe.

(2) Each bend must have a smooth contour and be free from buckling, cracks, or any other mechanical damage.

(3) On pipe containing a longitudinal weld, the longitudinal weld must be as near as practicable to the neutral axis of the bend unless:

(i) The bend is made with an internal bending mandrel; or

(ii) The pipe is 12 inches (305 millimeters) or less in outside diameter or has a diameter to wall thickness ratio less than 70.

(b) Each circumferential weld of steel pipe which is located where the stress during bending causes a permanent deformation in the pipe must be nondestructively tested either before or after the bending process.

(c) Wrought-steel welding elbows and transverse segments of these elbows may not be used for changes in direction on steel pipe that is 2 inches (51 millimeters) or more in diameter unless the arc length, as measured along the crotch, is at least 1 inch (25 millimeters).

[Amdt. No. 192–26, 41 FR 26018, June 24, 1976, as amended by Amdt. 192–29, 42 FR 42866, Aug. 25, 1977; Amdt. 192–29, 42 FR 60148, Nov. 25, 1977; Amdt. 192–49, 50 FR 13225, Apr. 3, 1985; Amdt. 192–85, 63 FR 37503, July 13, 1998]

See following procedures:

Bends and Elbows

**VGS Operations
&
Maintenance
Manual**

**Minimum Federal Safety Standards
Subpart G – General Construction Requirements for
Transmission Lines and Mains
Part 192.315
Wrinkle Bends in Steel Pipe
Effective Date: March 31, 2009
Page 1 of 1**

(a) A wrinkle bend may not be made on steel pipe to be operated at a pressure that produces a hoop stress of 30 percent, or more, of SMYS.

(b) Each wrinkle bend on steel pipe must comply with the following:

- (1) The bend must not have any sharp kinks.
- (2) When measured along the crotch of the bend, the wrinkles must be a distance of at least one pipe diameter.
- (3) On pipe 16 inches (406 millimeters) or larger in diameter, the bend may not have a deflection of more than $1\frac{1}{2}^{\circ}$ for each wrinkle.
- (4) On pipe containing a longitudinal weld the longitudinal seam must be as near as practicable to the neutral axis of the bend.

[35 FR 13257, Aug. 19, 1970, as amended by Amdt. 192–85, 63 FR 37503, July 16, 1998]

***See following procedure:
Bends and Elbows***

DRAFT - NOT FOR CONSTRUCTION

**VGS Operations
&
Maintenance
Manual**

**Minimum Federal Safety Standards
Subpart G – General Construction Requirements for
Transmission Lines and Mains
Part 192.317
Protection from Hazards
Effective Date: March 31, 2009
Page 1 of 1**

(a) The operator must take all practicable steps to protect each transmission line or main from washouts, floods, unstable soil, landslides, or other hazards that may cause the pipeline to move or to sustain abnormal loads. In addition, the operator must take all practicable steps to protect offshore pipelines from damage by mud slides, water currents, hurricanes, ship anchors, and fishing operations.

(b) Each aboveground transmission line or main, not located offshore or in inland navigable water areas, must be protected from accidental damage by vehicular traffic or other similar causes, either by being placed at a safe distance from the traffic or by installing barricades.

(c) Pipelines, including pipe risers, on each platform located offshore or in inland navigable waters must be protected from accidental damage by vessels.

[Amdt. 192–27, 41 FR 34606, Aug. 16, 1976, as amended by Amdt. 192–78, 61 FR 28784, June 6, 1996]

See following procedure:

Casings

Vaults

DRAFT - NOT FOR CONSTRUCTION

**VGS Operations
&
Maintenance
Manual**

**Minimum Federal Safety Standards
Subpart G – General Construction Requirements for
Transmission Lines and Mains
Part 192.319
Installation of Pipe in a Ditch
Effective Date: March 31, 2009
Page 1 of 1**

(a) When installed in a ditch, each transmission line that is to be operated at a pressure producing a hoop stress of 20 percent or more of SMYS must be installed so that the pipe fits the ditch so as to minimize stresses and protect the pipe coating from damage.

(b) When a ditch for a transmission line or main is backfilled, it must be backfilled in a manner that:

(1) Provides firm support under the pipe; and

(2) Prevents damage to the pipe and pipe coating from equipment or from the backfill material.

(c) All offshore pipe in water at least 12 feet (3.7 meters) deep but not more than 200 feet (61 meters) deep, as measured from the mean low tide, except pipe in the Gulf of Mexico and its inlets under 15 feet (4.6 meters) of water, must be installed so that the top of the pipe is below the natural bottom unless the pipe is supported by stanchions, held in place by anchors or heavy concrete coating, or protected by an equivalent means. Pipe in the Gulf of Mexico and its inlets under 15 feet (4.6 meters) of water must be installed so that the top of the pipe is 36 inches (914 millimeters) below the seabed for normal excavation or 18 inches (457 millimeters) for rock excavation.

[35 FR 13257, Aug. 19, 1970, as amended by Amdt. 192–27, 41 FR 34606, Aug. 16, 1976; Amdt. 192–78, 61 FR 28784, June 6, 1996; Amdt. 192–85, 63 FR 37503, July 13, 1998]

See following procedures:

Pipe Installation

DRAFT - NOT FOR CONSTRUCTION

**VGS Operations
&
Maintenance
Manual**

**Minimum Federal Safety Standards
Subpart G – General Construction Requirements for
Transmission Lines and Mains
Part 192.321
Installation of Plastic Pipe
Effective Date: March 31, 2009
Page 1 of 1**

- (a) Plastic pipe must be installed below ground level except as provided by paragraphs (g) and (h) of this section.
- (b) Plastic pipe that is installed in a vault or any other below grade enclosure must be completely encased in gas-tight metal pipe and fittings that are adequately protected from corrosion.
- (c) Plastic pipe must be installed so as to minimize shear or tensile stresses.
- (d) Thermoplastic pipe that is not encased must have a minimum wall thickness of 0.090 inch (2.29 millimeters), except that pipe with an outside diameter of 0.875 inch (22.3 millimeters) or less may have a minimum wall thickness of 0.062 inch (1.58 millimeters).
- (e) Plastic pipe that is not encased must have an electrically conducting wire or other means of locating the pipe while it is underground. Tracer wire may not be wrapped around the pipe and contact with the pipe must be minimized but is not prohibited. Tracer wire or other metallic elements installed for pipe locating purposes must be resistant to corrosion damage, either by use of coated copper wire or by other means.
- (f) Plastic pipe that is being encased must be inserted into the casing pipe in a manner that will protect the plastic. The leading end of the plastic must be closed before insertion.
- (g) Uncased plastic pipe may be temporarily installed above ground level under the following conditions:
- (1) The operator must be able to demonstrate that the cumulative aboveground exposure of the pipe does not exceed the manufacturer's recommended maximum period of exposure or 2 years, whichever is less.
 - (2) The pipe either is located where damage by external forces is unlikely or is otherwise protected against such damage.
 - (3) The pipe adequately resists exposure to ultraviolet light and high and low temperatures.
- (h) Plastic pipe may be installed on bridges provided that it is:
- (1) Installed with protection from mechanical damage, such as installation in a metallic casing;
 - (2) Protected from ultraviolet radiation; and
 - (3) Not allowed to exceed the pipe temperature limits specified in §192.123.

[35 FR 13257, Aug. 19, 1970, as amended by Amdt. 192-78, 61 FR 28784, June 6, 1996; Amdt. 192-85, 63 FR 37503, July 13, 1998; Amdt. 192-93, 68 FR 53900, Sept. 15, 2003; Amdt. 192-94, 69 FR 32895, June 14, 2004]

See following procedures:

Bends and Elbows

Casings

Locator Wire

Pipe Installation

**VGS Operations
&
Maintenance
Manual**

**Minimum Federal Safety Standards
Subpart G – General Construction Requirements for
Transmission Lines and Mains
Part 192.323
Casing
Effective Date: March 31, 2009
Page 1 of 1**

Each casing used on a transmission line or main under a railroad or highway must comply with the following:

- (a) The casing must be designed to withstand the superimposed loads.
- (b) If there is a possibility of water entering the casing, the ends must be sealed.
- (c) If the ends of an unvented casing are sealed and the sealing is strong enough to retain the maximum allowable operating pressure of the pipe, the casing must be designed to hold this pressure at a stress level of not more than 72 percent of SMYS.
- (d) If vents are installed on a casing, the vents must be protected from the weather to prevent water from entering the casing.

***See following procedure:
Casings***

DRAFT - NOT FOR CONSTRUCTION

**VGS Operations
&
Maintenance
Manual**

**Minimum Federal Safety Standards
Subpart G – General Construction Requirements for
Transmission Lines and Mains
Part 192.325
Underground Clearance
Effective Date: March 31, 2009
Page 1 of 1**

(a) Each transmission line must be installed with at least 12 inches (305 millimeters) of clearance from any other underground structure not associated with the transmission line. If this clearance cannot be attained, the transmission line must be protected from damage that might result from the proximity of the other structure.

(b) Each main must be installed with enough clearance from any other underground structure to allow proper maintenance and to protect against damage that might result from proximity to other structures.

(c) In addition to meeting the requirements of paragraph (a) or (b) of this section, each plastic transmission line or main must be installed with sufficient clearance, or must be insulated, from any source of heat so as to prevent the heat from impairing the serviceability of the pipe.

(d) Each pipe-type or bottle-type holder must be installed with a minimum clearance from any other holder as prescribed in §192.175(b).

[35 FR 13257, Aug. 19, 1970, as amended by Amdt. 192-85, 63 FR 37503, July 13, 1998]

See following procedures:

Boring

Underground Clearance

VGS Operations & Maintenance Manual	Minimum Federal Safety Standards Subpart G – General Construction Requirements for Transmission Lines and Mains Part 192.327 Cover Effective Date: March 31, 2009 Page 1 of 2
--	--

(a) Except as provided in paragraphs (c), (e), (f), and (g) of this section, each buried transmission line must be installed with a minimum cover as follows:

Location	Normal soil	Consolidated rock
Inches (Millimeters)		
Class 1 locations	30 (762)	18 (457)
Class 2, 3, and 4 locations	36 (914)	24 (610)
Drainage ditches of public roads and railroad crossings	36 (914)	24 (610)

(b) Except as provided in paragraphs (c) and (d) of this section, each buried main must be installed with at least 24 inches (610 millimeters) of cover.

(c) Where an underground structure prevents the installation of a transmission line or main with the minimum cover, the transmission line or main may be installed with less cover if it is provided with additional protection to withstand anticipated external loads.

(d) A main may be installed with less than 24 inches (610 millimeters) of cover if the law of the State or municipality:

- (1) Establishes a minimum cover of less than 24 inches (610 millimeters);
- (2) Requires that mains be installed in a common trench with other utility lines; and
- (3) Provides adequately for prevention of damage to the pipe by external forces.

(e) Except as provided in paragraph (c) of this section, all pipe installed in a navigable river, stream, or harbor must be installed with a minimum cover of 48 inches (1,219 millimeters) in soil or 24 inches (610 millimeters) in consolidated rock between the top of the pipe and the underwater natural bottom (as determined by recognized and generally accepted practices).

(f) All pipe installed offshore, except in the Gulf of Mexico and its inlets, under water not more than 200 feet (60 meters) deep, as measured from the mean low tide, must be installed as follows:

- (1) Except as provided in paragraph (c) of this section, pipe under water less than 12 feet (3.66 meters) deep, must be installed with a minimum cover of 36 inches (914 millimeters) in soil or 18 inches (457 millimeters) in consolidated rock between the top of the pipe and the natural bottom.
- (2) Pipe under water at least 12 feet (3.66 meters) deep must be installed so that the top of the pipe is below the natural bottom, unless the pipe is supported by stanchions, held in place by anchors or heavy concrete coating, or protected by an equivalent means.

(g) All pipelines installed under water in the Gulf of Mexico and its inlets, as defined in §192.3, must be installed in accordance with §192.612(b)(3).

[35 FR 13257, Aug. 19, 1970, as amended by Amdt. 192–27, 41 FR 34606, Aug. 16, 1976; Amdt. 192–78, 61 FR 28785, June 6, 1996; Amdt. 192–85, 63 FR 37503, July 13, 1998; Amdt. 192–98, 69 FR 48406, Aug. 10, 2004]

VGS Operations & Maintenance Manual	Minimum Federal Safety Standards Subpart G – General Construction Requirements for Transmission Lines and Mains Part 192.327 Cover Effective Date: March 31, 2009 Page 2 of 2
--	--

*See following procedure:
Cover*

DRAFT - NOT FOR CONSTRUCTION

**VGS Operations
&
Maintenance
Manual**

**Minimum Federal Safety Standards
Subpart G – General Construction Requirements for
Transmission Lines and Mains
Part 192.328
Additional construction requirements for steel pipe
using alternative maximum allowable operating
pressure
Effective Date: October 17, 2008
Page 1 of 1**

For a new or existing pipeline segment to be eligible for operation at the alternative maximum allowable operating pressure calculated under § 192.620, a segment must meet the following additional construction requirements. Records must be maintained, for the useful life of the pipeline, demonstrating compliance with these requirements:

- To address this construction issue: The pipeline segment must meet this additional construction requirement:
- (a) Quality assurance
- (1) The construction of the pipeline segment must be done under a quality assurance plan addressing pipe inspection, hauling and stringing, field bending, welding, non-destructive examination of girth welds, applying and testing field applied coating, lowering of the pipeline into the ditch, padding and backfilling, and hydrostatic testing.
- (2) The quality assurance plan for applying and testing field applied coating to girth welds must be:
- (i) Equivalent to that required under § 192.112(f)(3) for pipe; and
 - (ii) Performed by an individual with the knowledge, skills, and ability to assure effective coating application.
- (b) Girth welds
- (1) All girth welds on a new pipeline segment must be non-destructively examined in accordance with § 192.243(b) and (c)
- (c) Depth of cover
- (1) Notwithstanding any lesser depth of cover otherwise allowed in § 192.327, there must be at least 36 inches (914 millimeters) of cover or equivalent means to protect the pipeline from outside force damage.
- (2) In areas where deep tilling or other activities could threaten the pipeline, the top of the pipeline must be installed at least one foot below the deepest expected penetration of the soil.
- (d) Initial strength testing
- (1) The pipeline segment must not have experienced failures indicative of systemic material defects during strength testing, including initial hydrostatic testing. A root cause analysis, including metallurgical examination of the failed pipe, must be performed for any failure experienced to verify that it is not indicative of a systemic concern. The results of this root cause analysis must be reported to each PHMSA pipeline safety regional office where the pipe is in service at least 60 days prior to operating at the alternative MAOP. An operator must also notify a State pipeline safety authority when the pipeline is located in a State where PHMSA has an interstate agent agreement, or an intrastate pipeline is regulated by that State
- (e) Interference currents
- (1) For a new pipeline segment, the construction must address the impacts of induced alternating current from parallel electric transmission lines and other known sources of potential interference with corrosion control

[Amtd. 192-107, 73 FR 62147, October 17, 2008]

VGS Operations & Maintenance Manual	Minimum Federal Safety Standards Subpart I – Requirements for Corrosion Control Part 192.451 Scope Effective Date: March 31, 2009 Page 1 of 1
--	--

(a) This subpart prescribes minimum requirements for the protection of metallic pipelines from external, internal, and atmospheric corrosion.

(b) [Reserved]

[Amdt. 192-4, 36 FR 12302, June 30, 1971, as amended by Amdt. 192-27, 41 FR 34606, Aug. 16, 1976; Amdt. 192-33, 43 FR 39389, Sept. 5, 1978]

VGS - Corrosion control practices detailed in VGS procedures shall be applicable to steel transmission lines, mains and steel services unless otherwise specified.

DRAFT - NOT FOR CONSTRUCTION

VGS Operations & Maintenance Manual	Minimum Federal Safety Standards Subpart I – Requirements for Corrosion Control Part 192.452 How Does this Subpart Apply to Converted Pipelines and Regulated Onshore Gathering Lines? Effective Date: March 31, 2009 Page 1 of 1
--	--

(a) *Converted pipelines.* Notwithstanding the date the pipeline was installed or any earlier deadlines for compliance, each pipeline which qualifies for use under this part in accordance with §192.14 must meet the requirements of this subpart specifically applicable to pipelines installed before August 1, 1971, and all other applicable requirements within 1 year after the pipeline is readied for service. However, the requirements of this subpart specifically applicable to pipelines installed after July 31, 1971, apply if the pipeline substantially meets those requirements before it is readied for service or it is a segment which is replaced, relocated, or substantially altered.

(b) *Regulated onshore gathering lines.* For any regulated onshore gathering line under §192.9 existing on April 14, 2006, that was not previously subject to this part, and for any onshore gathering line that becomes a regulated onshore gathering line under §192.9 after April 14, 2006, because of a change in class location or increase in dwelling density:

(1) The requirements of this subpart specifically applicable to pipelines installed before August 1, 1971, apply to the gathering line regardless of the date the pipeline was actually installed; and

(2) The requirements of this subpart specifically applicable to pipelines installed after July 31, 1971, apply only if the pipeline substantially meets those requirements.

[Amdt. 192–30, 42 FR 60148, Nov. 25, 1977, as amended by Amdt. 192–102, 71 FR 13303, Mar. 15, 2006]

DRAFT - NOT FOR CONSTRUCTION

VGS Operations & Maintenance Manual	Minimum Federal Safety Standards Subpart I – Requirements for Corrosion Control Part 192.453 General Effective Date: March 31, 2009 Page 1 of 1
--	--

The corrosion control procedures required by §192.605(b)(2), including those for the design, installation, operation, and maintenance of cathodic protection systems, must be carried out by, or under the direction of, a person qualified in pipeline corrosion control methods.

[Amdt. 192–71, 59 FR 6584, Feb. 11, 1994]

***See following procedure:
Corrosion Control – Cathodic Protection***

DRAFT - NOT FOR CONSTRUCTION

**VGS Operations
&
Maintenance
Manual**

**Minimum Federal Safety Standards
Subpart I – Requirements for Corrosion Control
Part 192.455
External Corrosion Control: Buried or Submerged
Pipelines Installed after July 31, 1971
Effective Date: March 31, 2009
Page 1 of 1**

(a) Except as provided in paragraphs (b), (c), and (f) of this section, each buried or submerged pipeline installed after July 31, 1971, must be protected against external corrosion, including the following:

(1) It must have an external protective coating meeting the requirements of §192.461.

(2) It must have a cathodic protection system designed to protect the pipeline in accordance with this subpart, installed and placed in operation within 1 year after completion of construction.

(b) An operator need not comply with paragraph (a) of this section, if the operator can demonstrate by tests, investigation, or experience in the area of application, including, as a minimum, soil resistivity measurements and tests for corrosion accelerating bacteria, that a corrosive environment does not exist. However, within 6 months after an installation made pursuant to the preceding sentence, the operator shall conduct tests, including pipe-to-soil potential measurements with respect to either a continuous reference electrode or an electrode using close spacing, not to exceed 20 feet (6 meters), and soil resistivity measurements at potential profile peak locations, to adequately evaluate the potential profile along the entire pipeline. If the tests made indicate that a corrosive condition exists, the pipeline must be cathodically protected in accordance with paragraph (a)(2) of this section.

(c) An operator need not comply with paragraph (a) of this section, if the operator can demonstrate by tests, investigation, or experience that—

(1) For a copper pipeline, a corrosive environment does not exist; or

(2) For a temporary pipeline with an operating period of service not to exceed 5 years beyond installation, corrosion during the 5-year period of service of the pipeline will not be detrimental to public safety.

(d) Notwithstanding the provisions of paragraph (b) or (c) of this section, if a pipeline is externally coated, it must be cathodically protected in accordance with paragraph (a)(2) of this section.

(e) Aluminum may not be installed in a buried or submerged pipeline if that aluminum is exposed to an environment with a natural pH in excess of 8, unless tests or experience indicate its suitability in the particular environment involved.

(f) This section does not apply to electrically isolated, metal alloy fittings in plastic pipelines, if:

(1) For the size fitting to be used, an operator can show by test, investigation, or experience in the area of application that adequate corrosion control is provided by the alloy composition; and

(2) The fitting is designed to prevent leakage caused by localized corrosion pitting.

[Amdt. 192–4, 36 FR 12302, June 30, 1971, as amended at Amdt. 192–28, 42 FR 35654, July 11, 1977; Amdt. 192–39, 47 FR 9844, Mar. 8, 1982; Amdt. 192–78, 61 FR 28785, June 6, 1996; Amdt. 192–85, 63 FR 37504, July 13, 1998]

See following procedure:

Corrosion Control – Cathodic Protection

Copper and Aluminum

VGS does not use copper or aluminum pipelines.

**VGS Operations
&
Maintenance
Manual**

**Minimum Federal Safety Standards
Subpart I – Requirements for Corrosion Control
Part 192.457
External Corrosion Control: Buried or Submerged
Pipelines Installed before August 1, 1971
Effective Date: March 31, 2009
Page 1 of 1**

(a) Except for buried piping at compressor, regulator, and measuring stations, each buried or submerged transmission line installed before August 1, 1971, that has an effective external coating must be cathodically protected along the entire area that is effectively coated, in accordance with this subpart. For the purposes of this subpart, a pipeline does not have an effective external coating if its cathodic protection current requirements are substantially the same as if it were bare. The operator shall make tests to determine the cathodic protection current requirements.

(b) Except for cast iron or ductile iron, each of the following buried or submerged pipelines installed before August 1, 1971, must be cathodically protected in accordance with this subpart in areas in which active corrosion is found:

- (1) Bare or ineffectively coated transmission lines.
- (2) Bare or coated pipes at compressor, regulator, and measuring stations.
- (3) Bare or coated distribution lines.

[Amdt. 192–4, 36 FR 12302, June 30, 1971, as amended by Amdt. 192–33, 43 FR 29390, Sept. 5, 1978; Amdt. 192–93, 68 FR 53900, Sept. 15, 2003]

Any buried or submerged pipeline in areas where continuing corrosion is identified shall be cathodically protected in accordance with the Corrosion Control – Cathodic Protection procedure or replaced.

VGS Operations & Maintenance Manual	Minimum Federal Safety Standards Subpart I – Requirements for Corrosion Control Part 192.459 External Corrosion Control: Examination of Buried Pipeline when Exposed Effective Date: March 31, 2009 Page 1 of 1
--	--

Whenever an operator has knowledge that any portion of a buried pipeline is exposed, the exposed portion must be examined for evidence of external corrosion if the pipe is bare, or if the coating is deteriorated. If external corrosion requiring remedial action under §§192.483 through 192.489 is found, the operator shall investigate circumferentially and longitudinally beyond the exposed portion (by visual examination, indirect method, or both) to determine whether additional corrosion requiring remedial action exists in the vicinity of the exposed portion.

[Amdt. 192–87, 64 FR 56981, Oct. 22, 1999]

See following procedure:

Inspection

DRAFT - NOT FOR CONSTRUCTION

**VGS Operations
&
Maintenance
Manual**

**Minimum Federal Safety Standards
Subpart I – Requirements for Corrosion Control
Part 192.461
External Corrosion Control: Protective Coating
Effective Date: March 31, 2009
Page 1 of 1**

(a) Each external protective coating, whether conductive or insulating, applied for the purpose of external corrosion control must—

- (1) Be applied on a properly prepared surface;
- (2) Have sufficient adhesion to the metal surface to effectively resist underfilm migration of moisture;
- (3) Be sufficiently ductile to resist cracking;
- (4) Have sufficient strength to resist damage due to handling and soil stress; and
- (5) Have properties compatible with any supplemental cathodic protection.

(b) Each external protective coating which is an electrically insulating type must also have low moisture absorption and high electrical resistance.

(c) Each external protective coating must be inspected just prior to lowering the pipe into the ditch and backfilling, and any damage detrimental to effective corrosion control must be repaired.

(d) Each external protective coating must be protected from damage resulting from adverse ditch conditions or damage from supporting blocks.

(e) If coated pipe is installed by boring, driving, or other similar method, precautions must be taken to minimize damage to the coating during installation.

See following procedures:

Inspection

Corrosion Control – Protective Coating

**VGS Operations
&
Maintenance
Manual**

**Minimum Federal Safety Standards
Subpart I – Requirements for Corrosion Control
Part 192.463
External Corrosion Control: Cathodic Protection
Effective Date: March 31, 2009
Page 1 of 1**

(a) Each cathodic protection system required by this subpart must provide a level of cathodic protection that complies with one or more of the applicable criteria contained in appendix D of this part. If none of these criteria is applicable, the cathodic protection system must provide a level of cathodic protection at least equal to that provided by compliance with one or more of these criteria.

(b) If amphoteric metals are included in a buried or submerged pipeline containing a metal of different anodic potential—

(1) The amphoteric metals must be electrically isolated from the remainder of the pipeline and cathodically protected; or

(2) The entire buried or submerged pipeline must be cathodically protected at a cathodic potential that meets the requirements of appendix D of this part for amphoteric metals.

(c) The amount of cathodic protection must be controlled so as not to damage the protective coating or the pipe.

***See following procedures:
Corrosion Control – Cathodic Protection
Corrosion Control - Monitoring***

DRAFT - NOT FOR CONSTRUCTION

VGS Operations & Maintenance Manual	Minimum Federal Safety Standards Subpart I – Requirements for Corrosion Control Part 192.465 External Corrosion Control: Monitoring Effective Date: March 31, 2009 Page 1 of 1
--	---

(a) Each pipeline that is under cathodic protection must be tested at least once each calendar year, but with intervals not exceeding 15 months, to determine whether the cathodic protection meets the requirements of §192.463. However, if tests at those intervals are impractical for separately protected short sections of mains or transmission lines, not in excess of 100 feet (30 meters), or separately protected service lines, these pipelines may be surveyed on a sampling basis. At least 10 percent of these protected structures, distributed over the entire system must be surveyed each calendar year, with a different 10 percent checked each subsequent year, so that the entire system is tested in each 10-year period.

(b) Each cathodic protection rectifier or other impressed current power source must be inspected six times each calendar year, but with intervals not exceeding 21/2months, to insure that it is operating.

(c) Each reverse current switch, each diode, and each interference bond whose failure would jeopardize structure protection must be electrically checked for proper performance six times each calendar year, but with intervals not exceeding 21/2months. Each other interference bond must be checked at least once each calendar year, but with intervals not exceeding 15 months.

(d) Each operator shall take prompt remedial action to correct any deficiencies indicated by the monitoring.

(e) After the initial evaluation required by §§192.455(b) and (c) and 192.457(b), each operator must, not less than every 3 years at intervals not exceeding 39 months, reevaluate its unprotected pipelines and cathodically protect them in accordance with this subpart in areas in which active corrosion is found. The operator must determine the areas of active corrosion by electrical survey. However, on distribution lines and where an electrical survey is impractical on transmission lines, areas of active corrosion may be determined by other means that include review and analysis of leak repair and inspection records, corrosion monitoring records, exposed pipe inspection records, and the pipeline environment.

[Amdt. 192-4, 36 FR 12302, June 30, 1971, as amended by Amdt. 192-33, 43 FR 39390, Sept. 5, 1978; Amdt. 192-35A, 45 FR 23441, Apr. 7, 1980; Amdt. 192-85, 63 FR 37504, July 13, 1998; Amdt. 192-93, 68 FR 53900, Sept. 15, 2003]

See following procedures:

Corrosion Control – Monitoring

Corrosion Control – Remedial Measures

Unprotected Pipe

VGS does not have any unprotected pipe which would require re-evaluation per section (e).

**VGS Operations
&
Maintenance
Manual**

**Minimum Federal Safety Standards
Subpart I – Requirements for Corrosion Control
Part 192.467
External Corrosion Control: Electrical Isolation
Effective Date: March 31, 2009
Page 1 of 1**

(a) Each buried or submerged pipeline must be electrically isolated from other underground metallic structures, unless the pipeline and the other structures are electrically interconnected and cathodically protected as a single unit.

(b) One or more insulating devices must be installed where electrical isolation of a portion of a pipeline is necessary to facilitate the application of corrosion control.

(c) Except for unprotected copper inserted in ferrous pipe, each pipeline must be electrically isolated from metallic casings that are a part of the underground system. However, if isolation is not achieved because it is impractical, other measures must be taken to minimize corrosion of the pipeline inside the casing.

(d) Inspection and electrical tests must be made to assure that electrical isolation is adequate.

(e) An insulating device may not be installed in an area where a combustible atmosphere is anticipated unless precautions are taken to prevent arcing.

(f) Where a pipeline is located in close proximity to electrical transmission tower footings, ground cables or counterpoise, or in other areas where fault currents or unusual risk of lightning may be anticipated, it must be provided with protection against damage due to fault currents or lightning, and protective measures must also be taken at insulating devices.

[Amdt. 192-4, 36 FR 12302, June 30, 1971, as amended by Amdt. 192-33, 43 FR 39390, Sept. 5, 1978]

See following procedures:

Casings

Corrosion Control – Cathodic Protection

VGS Operations & Maintenance Manual	Minimum Federal Safety Standards Subpart I – Requirements for Corrosion Control Part 192.469 External Corrosion Control: Test Stations Effective Date: March 31, 2009 Page 1 of 1
--	--

Each pipeline under cathodic protection required by this subpart must have sufficient test stations or other contact points for electrical measurement to determine the adequacy of cathodic protection.

[Amdt. 192–27, 41 FR 34606, Aug. 16, 1976]

*See following procedure:
Corrosion Control – Cathodic Protection*

DRAFT - NOT FOR CONSTRUCTION

VGS Operations & Maintenance Manual	Minimum Federal Safety Standards Subpart I – Requirements for Corrosion Control Part 192.471 External Corrosion Control: Test Leads Effective Date: March 31, 2009 Page 1 of 1
--	---

- (a) Each test lead wire must be connected to the pipeline so as to remain mechanically secure and electrically conductive.
- (b) Each test lead wire must be attached to the pipeline so as to minimize stress concentration on the pipe.
- (c) Each bared test lead wire and bared metallic area at point of connection to the pipeline must be coated with an electrical insulating material compatible with the pipe coating and the insulation on the wire.

***See following procedure:
Corrosion Control – Cathodic Protection***

DRAFT - NOT FOR CONSTRUCTION

VGS Operations & Maintenance Manual	Minimum Federal Safety Standards Subpart I – Requirements for Corrosion Control Part 192.473 External Corrosion Control: Interference Currents Effective Date: March 31, 2009 Page 1 of 1
--	--

(a) Each operator whose pipeline system is subjected to stray currents shall have in effect a continuing program to minimize the detrimental effects of such currents.

(b) Each impressed current type cathodic protection system or galvanic anode system must be designed and installed so as to minimize any adverse effects on existing adjacent underground metallic structures.

[Amdt. 192-4, 36 FR 12302, June 30, 1971, as amended by Amdt. 192-33, 43 FR 39390, Sept. 5, 1978]

***See following procedure:
Corrosion Control – Cathodic Protection***

DRAFT - NOT FOR CONSTRUCTION

**VGS Operations
&
Maintenance
Manual**

**Minimum Federal Safety Standards
Subpart I – Requirements for Corrosion Control
Part 192.475
Internal Corrosion Control: General
Effective Date: March 31, 2009
Page 1 of 1**

(a) Corrosive gas may not be transported by pipeline, unless the corrosive effect of the gas on the pipeline has been investigated and steps have been taken to minimize internal corrosion.

(b) Whenever any pipe is removed from a pipeline for any reason, the internal surface must be inspected for evidence of corrosion. If internal corrosion is found—

(1) The adjacent pipe must be investigated to determine the extent of internal corrosion;

(2) Replacement must be made to the extent required by the applicable paragraphs of §§192.485, 192.487, or 192.489; and

(3) Steps must be taken to minimize the internal corrosion.

(c) Gas containing more than 0.25 grain of hydrogen sulfide per 100 cubic feet (5.8 milligrams/m³) at standard conditions (4 parts per million) may not be stored in pipe-type or bottle-type holders.

[Amdt. 192–4, 36 FR 12302, June 30, 1971, as amended by Amdt. 192–33, 43 FR 29390, Sept. 5, 1978; Amdt. 192–78, 61 FR 28785, June 6, 1996; Amdt. 192–85, 63 FR 37504, July 13, 1998]

VGS -

The gas VGS transports and distributes is commercially free of dust, solids, gums, and microbiological agents which can be corrosive to the pipeline. VGS shall minimize the potential for internal corrosion by keeping facilities clear of water and condensates.

**VGS Operations
&
Maintenance
Manual**

**Minimum Federal Safety Standards
Subpart I – Requirements for Corrosion Control
Part 192.476
Internal Corrosion Control: Design and Construction
of Transmission Line
Effective Date: March 31, 2009
Page 1 of 1**

(a) *Design and construction.* Except as provided in paragraph (b) of this section, each new transmission line and each replacement of line pipe, valve, fitting, or other line component in a transmission line must have features incorporated into its design and construction to reduce the risk of internal corrosion. At a minimum, unless it is impracticable or unnecessary to do so, each new transmission line or replacement of line pipe, valve, fitting, or other line component in a transmission line must:

- (1) Be configured to reduce the risk that liquids will collect in the line;
- (2) Have effective liquid removal features whenever the configuration would allow liquids to collect; and
- (3) Allow use of devices for monitoring internal corrosion at locations with significant potential for internal corrosion.

(b) *Exceptions to applicability.* The design and construction requirements of paragraph (a) of this section do not apply to the following:

- (1) Offshore pipeline; and
- (2) Pipeline installed or line pipe, valve, fitting or other line component replaced before May 23, 2007.

(c) *Change to existing transmission line.* When an operator changes the configuration of a transmission line, the operator must evaluate the impact of the change on internal corrosion risk to the downstream portion of an existing onshore transmission line and provide for removal of liquids and monitoring of internal corrosion as appropriate.

(d) *Records.* An operator must maintain records demonstrating compliance with this section. Provided the records show why incorporating design features addressing paragraph (a)(1), (a)(2), or (a)(3) of this section is impracticable or unnecessary, an operator may fulfill this requirement through written procedures supported by as-built drawings or other construction records.

[72 FR 20059, Apr. 23, 2007]

VGS Operations & Maintenance Manual	Minimum Federal Safety Standards Subpart I – Requirements for Corrosion Control Part 192.477 Internal Corrosion Control: Monitoring Effective Date: March 31, 2009 Page 1 of 1
--	---

If corrosive gas is being transported, coupons or other suitable means must be used to determine the effectiveness of the steps taken to minimize internal corrosion. Each coupon or other means of monitoring internal corrosion must be checked two times each calendar year, but with intervals not exceeding 7 1/2 months.

[Amdt. 192-33, 43 FR 39390, Sept. 5, 1978]

VGS -

VGS does not have corrosive gas.

DRAFT - NOT FOR CONSTRUCTION

**VGS Operations
&
Maintenance
Manual**

**Minimum Federal Safety Standards
Subpart I – Requirements for Corrosion Control
Part 192.479
Atmospheric Corrosion Control: General
Effective Date: March 31, 2009
Page 1 of 1**

(a) Each operator must clean and coat each pipeline or portion of pipeline that is exposed to the atmosphere, except pipelines under paragraph (c) of this section.

(b) Coating material must be suitable for the prevention of atmospheric corrosion.

(c) Except portions of pipelines in offshore splash zones or soil-to-air interfaces, the operator need not protect from atmospheric corrosion any pipeline for which the operator demonstrates by test, investigation, or experience appropriate to the environment of the pipeline that corrosion will—

(1) Only be a light surface oxide; or

(2) Not affect the safe operation of the pipeline before the next scheduled inspection.

[Amdt. 192–93, 68 FR 53901, Sept. 15, 2003]

See following procedures:

Corrosion Control - Atmospheric

DRAFT - NOT FOR CONSTRUCTION

VGS Operations & Maintenance Manual	Minimum Federal Safety Standards Subpart I – Requirements for Corrosion Control Part 192.481 Atmospheric Corrosion Control: Monitoring Effective Date: March 31, 2009 Page 1 of 1
--	--

(a) Each operator must inspect each pipeline or portion of pipeline that is exposed to the atmosphere for evidence of atmospheric corrosion, as follows:

If the pipeline is located:	Then the frequency of inspection is:
Onshore	At least once every 3 calendar years, but with intervals not exceeding 39 months
Offshore	At least once each calendar year, but with intervals not exceeding 15 months

(b) During inspections the operator must give particular attention to pipe at soil-to-air interfaces, under thermal insulation, under disbanded coatings, at pipe supports, in splash zones, at deck penetrations, and in spans over water.

(c) If atmospheric corrosion is found during an inspection, the operator must provide protection against the corrosion as required by §192.479.

[Amdt. 192–93, 68 FR 53901, Sept. 15, 2003]

See following procedures:

Corrosion Control - Atmospheric

VGS Operations & Maintenance Manual	Minimum Federal Safety Standards Subpart I – Requirements for Corrosion Control Part 192.483 Remedial Measures: General Effective Date: March 31, 2009 Page 1 of 1
--	---

(a) Each segment of metallic pipe that replaces pipe removed from a buried or submerged pipeline because of external corrosion must have a properly prepared surface and must be provided with an external protective coating that meets the requirements of §192.461.

(b) Each segment of metallic pipe that replaces pipe removed from a buried or submerged pipeline because of external corrosion must be cathodically protected in accordance with this subpart.

(c) Except for cast iron or ductile iron pipe, each segment of buried or submerged pipe that is required to be repaired because of external corrosion must be cathodically protected in accordance with this subpart.

***See following procedure:
Cathodic Protection – Remedial Measures***

DRAFT - NOT FOR CONSTRUCTION

VGS Operations & Maintenance Manual	Minimum Federal Safety Standards Subpart I – Requirements for Corrosion Control Part 192.485 Remedial Measures: Transmission Lines Effective Date: March 31, 2009 Page 1 of 1
--	--

(a) *General corrosion.* Each segment of transmission line with general corrosion and with a remaining wall thickness less than that required for the MAOP of the pipeline must be replaced or the operating pressure reduced commensurate with the strength of the pipe based on actual remaining wall thickness. However, corroded pipe may be repaired by a method that reliable engineering tests and analyses show can permanently restore the serviceability of the pipe. Corrosion pitting so closely grouped as to affect the overall strength of the pipe is considered general corrosion for the purpose of this paragraph.

(b) *Localized corrosion pitting.* Each segment of transmission line pipe with localized corrosion pitting to a degree where leakage might result must be replaced or repaired, or the operating pressure must be reduced commensurate with the strength of the pipe, based on the actual remaining wall thickness in the pits.

(c) Under paragraphs (a) and (b) of this section, the strength of pipe based on actual remaining wall thickness may be determined by the procedure in ASME/ANSI B31G or the procedure in AGA Pipeline Research Committee Project PR 3–805 (with RSTRENG disk). Both procedures apply to corroded regions that do not penetrate the pipe wall, subject to the limitations prescribed in the procedures.

[Amdt. 192–4, 36 FR 12302, June 30, 1971, as amended by Amdt. 192–33, 43 FR 89390, Sept. 5, 1978; Amdt. 192–78, 61 FR 28785, June 6, 1996; Amdt. 192–88, 64 FR 69664, Dec. 14, 1999]

VGS –

VGS will comply with this section.

DRAFT - NOT FOR CONSTRUCTION

VGS Operations & Maintenance Manual	Minimum Federal Safety Standards Subpart I – Requirements for Corrosion Control Part 192.487 Remedial Measures: Distribution Lines other than Cast Iron or Ductile Iron Lines Effective Date: March 31, 2009 Page 1 of 1
--	---

(a) *General corrosion.* Except for cast iron or ductile iron pipe, each segment of generally corroded distribution line pipe with a remaining wall thickness less than that required for the MAOP of the pipeline, or a remaining wall thickness less than 30 percent of the nominal wall thickness, must be replaced. However, corroded pipe may be repaired by a method that reliable engineering tests and analyses show can permanently restore the serviceability of the pipe. Corrosion pitting so closely grouped as to affect the overall strength of the pipe is considered general corrosion for the purpose of this paragraph.

(b) *Localized corrosion pitting.* Except for cast iron or ductile iron pipe, each segment of distribution line pipe with localized corrosion pitting to a degree where leakage might result must be replaced or repaired.

[Amdt. 192-4, 36 FR 12302, June 30, 1971, as amended by Amdt. 192-88, 64 FR 69665, Dec. 14, 1999]

***See following procedure:
Corrosion Control – Remedial Measures***

DRAFT - NOT FOR CONSTRUCTION

VGS Operations & Maintenance Manual	Minimum Federal Safety Standards Subpart I – Requirements for Corrosion Control Part 192.489 Remedial Measures: Cast Iron and Ductile Iron Pipelines Effective Date: March 31, 2009 Page 1 of 1
--	--

(a) *General graphitization*. Each segment of cast iron or ductile iron pipe on which general graphitization is found to a degree where a fracture or any leakage might result, must be replaced.

(b) *Localized graphitization*. Each segment of cast iron or ductile iron pipe on which localized graphitization is found to a degree where any leakage might result, must be replaced or repaired, or sealed by internal sealing methods adequate to prevent or arrest any leakage.

VGS does not have Cast Iron pipelines.

DRAFT - NOT FOR CONSTRUCTION

VGS Operations & Maintenance Manual	Minimum Federal Safety Standards Subpart I – Requirements for Corrosion Control Part 192.490 Direct Assessment Effective Date: March 31, 2009 Page 1 of 1
--	--

Each operator that uses direct assessment as defined in §192.903 on an onshore transmission line made primarily of steel or iron to evaluate the effects of a threat in the first column must carry out the direct assessment according to the standard listed in the second column. These standards do not apply to methods associated with direct assessment, such as close interval surveys, voltage gradient surveys, or examination of exposed pipelines, when used separately from the direct assessment process.

Threat	Standard ¹
External corrosion	§192.925 ²
Internal corrosion in pipelines that transport dry gas	§192.927
Stress corrosion cracking	§192.929

¹For lines not subject to subpart O of this part, the terms “covered segment” and “covered pipeline segment” in §§192.925, 192.927, and 192.929 refer to the pipeline segment on which direct assessment is performed.

²In §192.925(b), the provision regarding detection of coating damage applies only to pipelines subject to subpart O of this part.

[Amdt. 192–101, 70 FR 61575, Oct. 25, 2005]

VGS will comply with this section.

DRAFT - NOT FOR CONSTRUCTION

**VGS Operations
&
Maintenance
Manual**

**Minimum Federal Safety Standards
Subpart I – Requirements for Corrosion Control
Part 192.491
Corrosion Control Records
Effective Date: March 31, 2009
Page 1 of 1**

(a) Each operator shall maintain records or maps to show the location of cathodically protected piping, cathodic protection facilities, galvanic anodes, and neighboring structures bonded to the cathodic protection system. Records or maps showing a stated number of anodes, installed in a stated manner or spacing, need not show specific distances to each buried anode.

(b) Each record or map required by paragraph (a) of this section must be retained for as long as the pipeline remains in service.

(c) Each operator shall maintain a record of each test, survey, or inspection required by this subpart in sufficient detail to demonstrate the adequacy of corrosion control measures or that a corrosive condition does not exist. These records must be retained for at least 5 years, except that records related to §§192.465 (a) and (e) and 192.475(b) must be retained for as long as the pipeline remains in service.

[Amdt. 192–78, 61 FR 28785, June 6, 1996]

See following procedure:

Records

DRAFT - NOT FOR CONSTRUCTION

VGS Operations & Maintenance Manual	Minimum Federal Safety Standards Subpart J – Test Requirements Part 192.501 Scope Effective Date: March 31, 2009 Page 1 of 1
--	---

This subpart prescribes minimum leak-test and strength-test requirements for pipelines.

DRAFT - NOT FOR CONSTRUCTION

(a) No person may operate a new segment of pipeline, or return to service a segment of pipeline that has been relocated or replaced, until—

(1) It has been tested in accordance with this subpart and §192.619 to substantiate the maximum allowable operating pressure; and

(2) Each potentially hazardous leak has been located and eliminated.

(b) The test medium must be liquid, air, natural gas, or inert gas that is—

(1) Compatible with the material of which the pipeline is constructed;

(2) Relatively free of sedimentary materials; and

(3) Except for natural gas, nonflammable.

(c) Except as provided in §192.505(a), if air, natural gas, or inert gas is used as the test medium, the following maximum hoop stress limitations apply:

Class location	Maximum hoop stress allowed as percentage of SMYS	
	Natural gas	Air or inert gas
1	80	80
2	30	75
3	30	50
4	30	40

(d) Each joint used to tie in a test segment of pipeline is excepted from the specific test requirements of this subpart, but each non-welded joint must be leak tested at not less than its operating pressure.

[35 FR 13257, Aug. 19, 1970, as amended by Amdt. 192-58, 53 FR 1635, Jan. 21, 1988; Amdt. 192-60, 53 FR 36029, Sept. 16, 1988; Amdt. 192-60A, 54 FR 5485, Feb. 3, 1989]

***See following procedure:
Test Requirements***

**VGS Operations
&
Maintenance
Manual**

**Minimum Federal Safety Standards
Subpart J – Test Requirements
Part 192.505
Strength Test Requirements for Steel Pipeline to
Operate at a Hoop Stress of 30 percent or more of
SMYS
Effective Date: March 31, 2009
Page 1 of 1**

(a) Except for service lines, each segment of a steel pipeline that is to operate at a hoop stress of 30 percent or more of SMYS must be strength tested in accordance with this section to substantiate the proposed maximum allowable operating pressure. In addition, in a Class 1 or Class 2 location, if there is a building intended for human occupancy within 300 feet (91 meters) of a pipeline, a hydrostatic test must be conducted to a test pressure of at least 125 percent of maximum operating pressure on that segment of the pipeline within 300 feet (91 meters) of such a building, but in no event may the test section be less than 600 feet (183 meters) unless the length of the newly installed or relocated pipe is less than 600 feet (183 meters). However, if the buildings are evacuated while the hoop stress exceeds 50 percent of SMYS, air or inert gas may be used as the test medium.

(b) In a Class 1 or Class 2 location, each compressor station regulator station, and measuring station, must be tested to at least Class 3 location test requirements.

(c) Except as provided in paragraph (e) of this section, the strength test must be conducted by maintaining the pressure at or above the test pressure for at least 8 hours.

(d) If a component other than pipe is the only item being replaced or added to a pipeline, a strength test after installation is not required, if the manufacturer of the component certifies that—

(1) The component was tested to at least the pressure required for the pipeline to which it is being added;

(2) The component was manufactured under a quality control system that ensures that each item manufactured is at least equal in strength to a prototype and that the prototype was tested to at least the pressure required for the pipeline to which it is being added; or

(3) The component carries a pressure rating established through applicable ASME/ANSI, MSS specifications, or by unit strength calculations as described in §192.143.

(e) For fabricated units and short sections of pipe, for which a post installation test is impractical, a preinstallation strength test must be conducted by maintaining the pressure at or above the test pressure for at least 4 hours.

[35 FR 13257, Aug. 19, 1970, as amended by Amdt. 192–85, 63 FR 37504, July 13, 1998; Amdt. 192–94, 69 FR 32895, June 14, 2004; Amdt. 195–94, 69 FR 54592, Sept. 9, 2004]

**VGS Operations
&
Maintenance
Manual**

**Minimum Federal Safety Standards
Subpart J – Test Requirements
Part 192.507
Test Requirements for Pipelines to Operate at a
Hoop Stress less than 30 percent of SMYS and at or
above 100 p.s.i. (689 kPa) gage
Effective Date: March 31, 2009
Page 1 of 1**

Except for service lines and plastic pipelines, each segment of a pipeline that is to be operated at a hoop stress less than 30 percent of SMYS and at or above 100 p.s.i. (689 kPa) gage must be tested in accordance with the following:

- (a) The pipeline operator must use a test procedure that will ensure discovery of all potentially hazardous leaks in the segment being tested.
- (b) If, during the test, the segment is to be stressed to 20 percent or more of SMYS and natural gas, inert gas, or air is the test medium—
- (1) A leak test must be made at a pressure between 100 p.s.i. (689 kPa) gage and the pressure required to produce a hoop stress of 20 percent of SMYS; or
 - (2) The line must be walked to check for leaks while the hoop stress is held at approximately 20 percent of SMYS.
- (c) The pressure must be maintained at or above the test pressure for at least 1 hour.

[35 FR 13257, Aug. 19, 1970, as amended by Amdt. 192–58, 53 FR 1635, Jan. 21, 1988; Amdt. 192–85, 63 FR 37504, July 13, 1998]

DRAFT - NOT FOR CONSTRUCTION

**VGS Operations
&
Maintenance
Manual**

**Minimum Federal Safety Standards
Subpart J – Test Requirements
Part 192.509
Test Requirements for Pipelines to Operate below
100 p.s.i. (689 kPa) gage
Effective Date: March 31, 2009
Page 1 of 1**

Except for service lines and plastic pipelines, each segment of a pipeline that is to be operated below 100 p.s.i. (689 kPa) gage must be leak tested in accordance with the following:

- (a) The test procedure used must ensure discovery of all potentially hazardous leaks in the segment being tested.
- (b) Each main that is to be operated at less than 1 p.s.i. (6.9 kPa) gage must be tested to at least 10 p.s.i. (69 kPa) gage and each main to be operated at or above 1 p.s.i. (6.9 kPa) gage must be tested to at least 90 p.s.i. (621 kPa) gage.

[35 FR 13257, Aug. 19, 1970, as amended by Amdt. 192–58, 53 FR 1635, Jan. 21, 1988; Amdt. 192–85, 63 FR 37504, July 13, 1998]

***See following procedure:
Test Requirements***

DRAFT - NOT FOR CONSTRUCTION

VGS Operations & Maintenance Manual	Minimum Federal Safety Standards Subpart J – Test Requirements Part 192.511 Test Requirements for Service Lines Effective Date: March 31, 2009 Page 1 of 1
--	---

(a) Each segment of a service line (other than plastic) must be leak tested in accordance with this section before being placed in service. If feasible, the service line connection to the main must be included in the test; if not feasible, it must be given a leakage test at the operating pressure when placed in service.

(b) Each segment of a service line (other than plastic) intended to be operated at a pressure of at least 1 p.s.i. (6.9 kPa) gage but not more than 40 p.s.i. (276 kPa) gage must be given a leak test at a pressure of not less than 50 p.s.i. (345 kPa) gage.

(c) Each segment of a service line (other than plastic) intended to be operated at pressures of more than 40 p.s.i. (276 kPa) gage must be tested to at least 90 p.s.i. (621 kPa) gage, except that each segment of a steel service line stressed to 20 percent or more of SMYS must be tested in accordance with §192.507 of this subpart.

[35 FR 13257, Aug. 19, 1970, as amended by Amdt. 192-74, 61 FR 18517, Apr. 26, 1996; Amdt 192-85, 63 FR 37504, July 13, 1998]

***See following procedure:
Test Requirements***

DRAFT - NOT FOR CONSTRUCTION

**VGS Operations
&
Maintenance
Manual**

**Minimum Federal Safety Standards
Subpart J – Test Requirements
Part 192.513
Test Requirements for Plastic Pipelines
Effective Date: March 31, 2009
Page 1 of 1**

- (a) Each segment of a plastic pipeline must be tested in accordance with this section.
- (b) The test procedure must insure discovery of all potentially hazardous leaks in the segment being tested.
- (c) The test pressure must be at least 150 percent of the maximum operating pressure or 50 p.s.i. (345 kPa) gage, whichever is greater. However, the maximum test pressure may not be more than three times the pressure determined under §192.121, at a temperature not less than the pipe temperature during the test.
- (d) During the test, the temperature of thermoplastic material may not be more than 100°F (38°C), or the temperature at which the material's long-term hydrostatic strength has been determined under the listed specification, whichever is greater.

[35 FR 13257, Aug. 19, 1970, as amended by Amdt. 192-77, 61 FR 27793, June 3, 1996; 61 FR 45905, Aug. 30, 1996; Amdt. 192-85, 63 FR 37504, July 13, 1998]

DRAFT - NOT FOR CONSTRUCTION

VGS Operations & Maintenance Manual	Minimum Federal Safety Standards Subpart J – Test Requirements Part 192.515 Environmental Protection and Safety Requirements Effective Date: March 31, 2009 Page 1 of 1
--	--

(a) In conducting tests under this subpart, each operator shall insure that every reasonable precaution is taken to protect its employees and the general public during the testing. Whenever the hoop stress of the segment of the pipeline being tested will exceed 50 percent of SMYS, the operator shall take all practicable steps to keep persons not working on the testing operation outside of the testing area until the pressure is reduced to or below the proposed maximum allowable operating pressure.

(b) The operator shall insure that the test medium is disposed of in a manner that will minimize damage to the environment.

DRAFT - NOT FOR CONSTRUCTION

**VGS Operations
&
Maintenance
Manual**

**Minimum Federal Safety Standards
Subpart J – Test Requirements
Part 192.517
Records
Effective Date: March 31, 2009
Page 1 of 1**

(a) Each operator shall make, and retain for the useful life of the pipeline, a record of each test performed under §§192.505 and 192.507. The record must contain at least the following information:

- (1) The operator's name, the name of the operator's employee responsible for making the test, and the name of any test company used.
- (2) Test medium used.
- (3) Test pressure.
- (4) Test duration.
- (5) Pressure recording charts, or other record of pressure readings.
- (6) Elevation variations, whenever significant for the particular test.
- (7) Leaks and failures noted and their disposition.

(b) Each operator must maintain a record of each test required by §§192.509, 192.511, and 192.513 for at least 5 years.

[35 FR 13257, Aug. 19, 1970, as amended by Amdt. 192-93, 68 FR 53901, Sept. 15, 2003]

See following procedure:

Records

DRAFT - NOT FOR CONSTRUCTION

Procedures – Table of Contents

Bends & Elbows	Repairs – Steel Pipe
Blasting	Route Planning, Layout & Marking
Boring	Steel Pipe – General
Branch Connections	Test Requirements
Casings and Sleeves	Third Party Damage Documentation
Clean-up, Paving & Maintenance	Tie-Ins
Corrosion Control – Cathodic Protection	Underground Clearance
Corrosion Control – Protective Coating	Valves
Cover	Welding
Direct Burial	
Excavation, Trenching & Backfilling	
Fittings	
Horizontal Directional Drilling	
Hot Tapping	
Inspection	
Installation of Steel Pipe – HDD Pull Back	
Permits, Easements & Rights of Way	
Pigging – New Construction	
Purging	

DRAFT - NOT FOR CONSTRUCTION

VGS Operating Procedures	Bends & Elbows Effective Date: April 1, 2013 Page 1 of 2
---	---

Referring Section:

192.303 – Compliance with Specifications or Standards

192.313 – Bends and elbows

192.315 – Wrinkle Bends in Steel Pipe

192.321 – Installation of plastic pipe

Bends and Deflections

Steel Pipe

Changes in direction for steel pipe installation shall be achieved only through the use of butt-welding elbows and cold-bending as outlined below. Steel butt-welding elbows are the preferred method for executing deflections in steel mains. Transverse sections cut from welding elbows may be used, provided the arc length measured across the crotch is at least 1" on pipe sizes of 2" and larger.

Cold-bending may be performed on steel pipe for smooth bends only. The minimum length of pipe required to achieve a bend may be determined by the formula below as derived from PIPE LINE RULES OF THUMB HANDBOOK, Sixth Edition, Elsevier Publishing Company, pgs. 48-49.

$$L = (26.4 \times D \times d) / 12$$

Where:

- L = length of pipe bend in a continuous arc in feet
- D = Number of degrees in the bend
- d = outside diameter of pipe in inches
(for steel pipe with SMYS = 35,000 psi)

If the designed bend cannot meet these criteria any new design must be approved by the Engineering Department.

Longitudinal welds in any bend shall be kept near the neutral axis of the bend.

Miter bends are not allowed in any situation.

Plastic Pipe

Changes in direction for plastic pipe installations shall be achieved only through the use of cold-bending or approved fittings for plastic pipe. Cold-bends should be limited to a

minimum bend radius of 25 times the outside diameter of the pipe for SDR11.

$R=25d$

R = minimum bend radius for the pipe (inches)
d = pipe outside diameter (inches)

Pipe Diameter (inches)	Minimum Bend Radius (inches)
3/4"	18 3/4"
2"	50"
4"	100"
6"	150"
8"	200"
10"	250"

(NOTE: The aforementioned statement is easily confusing because 2" PE (plastic) pipe usually comes in a coil with a radius less than 50 inches. The O & M Manual cites a larger bend diameter for installations because the pipe manufacturer specifies different allowable bend radii for short term bends (transportation and storage) and long term bends (installed in the ground)).

According to the Performance Pipe Bulletin PP 310 (issued December 2011), the Long Term Minimum Cold-Bending Radius for PE pipe is 25 times the pipe diameter and the Short Term Minimum Bending Radius is 13 times the pipe diameter for SDR11 pipe.

DRAFT - NOT FOR CONSTRUCTION

VGS Operating Procedures	Blasting Effective Date: April 13, 2012 Page 1 of 1
---	--

Referring section:

192.303 – Compliance with specifications or standards

Blasting

Blasting shall not be performed by anyone other than licensed personnel. All State and local regulations governing blasting operations shall be adhered to.

If an excavation requires blasting, approval must first be obtained from an Operations Manager and the VP of Operations.

Blasting occurring near Pipeline Facilities

Any blasting or potential blasting noted in the area of pipeline facilities shall be reported to an operations manager or supervisor. The Operations Manager may then assign personnel to monitor, patrol or survey the area as appropriate.

The employee assigned to monitor, patrol or survey the area will contact the blasting contractor on site and fill out an Inspector's Daily Blasting Report with the details of the blasting in the area of the pipelines.

The employee will consult with the blasting contractor to determine if the blasting vibrations will be at or above 2 inches per second (ips) Peak Particle Velocity. If the 2 ips peak particle velocity is going to be seen at the pipelines the employee will communicate to the blasting contractor that blasting will need to be suspended until it can be determined that no facilities will be damaged. The employee will notify an Operations Manager or Supervisor of the situation and a site meeting will need to be coordinated with the blasting contractor to discuss the safety of the facilities.

If the blasting in the area is below the 2 ips peak particle velocity the employee will leak survey the area prior to and after the blasting. All the details of the blasting and surveying will be documented on the Inspectors Daily Blasting Report.

DRAFT - NOT FOR CONSTRUCTION

VGS Operating Procedures	Boring Effective Date: April 13, 2012 Page 1 of 1
---	--

Referring Sections:

192.303 – Compliance with specifications or standards

192.325 – Underground clearance

192.361 – Service lines: Installation

Related Procedure: Horizontal Directional Drilling

Boring

All known underground piping and structures must be located in accordance with Vermont Underground Damage Prevention Law rules and regulations before boring is started.

Boring should not be done within 5 feet of buried electrical lines if the bore is going to parallel the buried electrical line for more than 5 feet. Boring shall not be done within 5' of any electrical utility pedestal. When installing pipe near a utility pedestal, the trench must be dug by hand, from the pedestal for a distance extending (5) feet from the edge of the pedestal in each direction, or until clear of all buried utility facilities.

If the bore is going to cross marked utilities, the location of the utilities must be visually identified at the location where the bore will cross the utilities. The location of marked utilities must also be visually determined, at reasonable intervals, when the bore will closely parallel the adjacent utilities. Holes made to identify the location of nearby utilities should remain open until the work is completed so on site personnel can verify that the bore did not damage the nearby utilities. Do not bore if unable to locate buried lines, call the applicable utility company for guidance in such cases. Do not bore if the subsoil contains obvious quantities of large stones or rock that could deflect the pipe while it is being bored through the ground.

The boring pipe and head will be larger than the outside diameter (including coating thickness) of the coupling on the gas pipe to be installed. Align the boring equipment carefully.

When the bore is complete, attach the new pipe to the boring rod. Each joint in the gas pipe will be made gas tight and coated. The entire length of the coated pipe will be checked for coating flaws before installation. Do not build up the coating thickness on the pipe or coupling larger than the diameter of the boring head. Insert the pipe carefully so the coating will not be damaged during the installation.

In all boring where polyethylene pipe is being installed, a locator wire shall be installed with the pipe. (See Locator Wire procedure.)

VGS Operating Procedures	Branch Connections Effective Date: December 1, 2010 Page 1 of 1
---	--

Referring section:

192.155 – Welded branch connections

192.303 – Compliance with Specifications or Standards

Branch connections in new main construction shall be made using the following techniques where both the run and branch mains are part of new construction:

Steel Run-Steel Branch

Approved methods for this connection are:

1. Weld tee with a weld reducer, if required.
2. Weldolet with a hole cut through the side wall of run main.
3. Tapping tee with a hole cut in top of run main or side of main.
4. Other approved “No Blo” weld fittings

Steel Run - Plastic Branch

Approved methods for this connection are:

1. Approved weld fittings.
2. No blo tee branch connections - These tie-ins are to be made with no-blo type tee line stopper fittings and are utilized when installing 2" through 6" plastic mains from existing larger sized steel mains.
3. Line stopper – Mueller/Williamson Fittings - This type tie-in is used when a branch extension of the same size as the existing steel main is required.

DRAFT - NOT FOR CONSTRUCTION

DRAFT - NOT FOR CONSTRUCTION

Referring sections:

192.317 – Protection from hazards

192.321 – Installation of plastic pipe

192.323 – Casing

192.467 – External corrosion control: Electrical isolation

Casing requirements for steel gas mains and transmission pipelines will be based on calculations outlined in American Petroleum Institute recommended practice API - RP-1102.

All casings and sleeves shall be installed at a minimum cover of 30" unless otherwise specified. Casings and sleeves shall have even bearing on trench bottom or shall be fastened, as required, to any structure, such as a bridge. Non-metallic sleeves may be used in some locations, such as new developments. The Engineering or Construction Departments will determine if use of sleeves is acceptable.

All casings will be designed to account for carrier flexibility, crossing camber, casing insulator and end-seal types. Spacing of insulators shall depend on size of carrier pipe and camber of crossing so that contact between carrier pipe and casing is avoided. In the design of casings for crossing railroad rights-of-way, the requirements for the railroad to be crossed shall be followed.

Casing insulators shall be installed on the carrier pipe at the required spacing. In all cases insulators shall be installed within one foot of the ends of the casing. All insulators shall be checked for snug fit.

Casings shall have the ends deburred and inside checked for cleanliness to assist in carrier insertion and to minimize carrier damage. Welds on casing joints shall have no excess penetration that would cause damage to the carrier pipe or restrict the insertion of the carrier pipe.

Upon insertion of carrier pipe into casing or sleeve, the leading end of the carrier pipe should be covered to prevent foreign matter from entering. The insertion should proceed without excessive force. Upon completion of the insertion, the carrier pipe should rest upon well-compacted earth at both ends. End seals for the casing shall be installed to prevent entry of water or soil.

Railroad Crossings

Transmission lines or mains crossing under railroad tracks or sidings shall be installed in a casing when required by the Railroad Authority. When such a casing is required, the

specifications of the particular railroad shall apply, but normally the casing should not extend beyond the right-of-way.

Bridges, Overpasses and Vaults

Where transmission lines or mains will be installed on bridges or overpasses or through vaults, the pipeline shall be designed to eliminate or minimize external stress caused by non-uniform support of the piping or where external temperature change will be a factor. Such designs shall be approved by the Engineering Department.

Casings for pipe shall be installed on such structures when required. Plastic pipe is prohibited from use as above-grade piping unless cased. On bridges or overpasses, the installation shall maintain electrical isolation of the carrier pipe from the structure.

Highway and Road Crossings - Mains

Casings or sleeves for mains shall be specified under highways or roadways when required by either the governmental authority responsible for the maintenance of the highway or roadway or an operations department supervisor or manager. Unless otherwise approved by the Construction or Engineering Departments, all distribution mains installed at road crossings at a depth less than 36" to top of pipe will be installed in a protective casing. Casing or sleeve diameter and specific design will be determined by the Construction or Engineering Departments on a case-by-case basis.

Highway and Road Crossings – Transmission Pipelines

Installation of transmission pressure pipelines at road crossings will be reviewed by the Engineering Department for determination of casing requirements.

Cathodic Protection

Refer to Corrosion Control – Cathodic Protection.

VGS Operating Procedures	Clean-up, Paving & Maintenance Effective Date: April 13, 2012 Page 1 of 1
---	--

Referring Sections:

192.303 – Compliance with specifications or standards

192.361 – Service lines: Installation

Post-Construction Clean Up

All excess backfill material shall be removed from the job site.

All disturbed areas shall be restored as close to original condition as possible and to state and/or municipality standards.

Temporary or Permanent Paving

All roadway openings shall be paved as soon as practical upon completion of the backfilling and compacting.

The edge of the trench to be paved is to be cleaned and scarified to assure good bonding of the temporary paving. Temporary paving shall be a minimum of 2" thick and not crowned more than 2" above the adjacent pavement. Only openings where others will provide paving need not be temporarily paved.

Temporary paving shall be placed over any excavations in the roadway or sidewalk area if required.

Permanent paving shall be done in accordance with the local jurisdiction.

Clean-up and Maintenance

The trench area shall be cleaned of rocks, debris and excess materials following construction. The trench and adjacent areas shall be maintained until permanent restoration of pavement is completed.

DRAFT - NOT FOR CONSTRUCTION

Referring Sections:

192.453 – Requirements for Corrosion Control – General

192.455 – External corrosion control: Buried or submerged pipelines installed after July 31, 1971

192.457 – External corrosion control: Buried or submerged pipelines installed before July 31, 1971

192.463 – External corrosion control: Cathodic Protection

192.467 – External corrosion control: Electrical isolation

192.469 – External corrosion control: Test stations

192.471 – External corrosion control: Test leads

192.473 – External corrosion control: Interference currents

49 CFR 192 - Appendix D

See also following procedure:

Inspection

Corrosion Control procedures, including those for the design, installation, operation and maintenance of cathodic protection systems, must be carried out by, or under the direction of, a person qualified by experience and training in pipeline corrosion control methods.

Cathodic Protection Design Procedure:

All new steel transmission, distribution and service installations will be reviewed by the Corrosion Technician, and/or the Manager of Engineering, for inclusion of the proper cathodic protection devices, anodes, insulators, test stations, etc. Changes or modifications to new or existing systems shall not be permitted unless the Manager of Engineering approves such changes.

All new steel pipe installations will have a cathodic protection system designed to protect the pipeline in its entirety within one year of installation. If any deficiencies should be discovered, they will be reviewed by the Corrosion Technician and corrective measures will be recommended.

When practical, the following corrosion control data should be recorded on the initial survey of a new steel pipeline installation:

1. Location of All Test Stations
2. Pipe Coating Resistance - when practical
3. Protective Current Applied to New Pipe - when practical
4. Pipe to Soil Potentials of New Pipe (services and mains less than 100' in length.)

Electrical isolation shall be designed and maintained with the use of insulating devices such as insulating unions, flanges, insulating joints, fiberglass shields, casing seals and link seals. Typical locations where insulating devices should be installed include:

1. Metallic structures, such as bridges, pipe support stanchions, piling, and reinforced concrete structures.
2. Casings and sleeves
3. River weights and pipe anchors
4. Gate stations
5. Service risers
6. Information gathering systems such as SCADA devices

Coated steel carrier pipe must be electrically isolated from metallic casings with the use of insulating devices such as casing seals and link seals. Care shall be used when inserting the coated carrier into the casing to reduce the possibility of damaging the coating and creating electrical shorts. Electrical isolation shall be confirmed at all installations.

Electrical insulators are not to be installed in an area where a combustible atmosphere is anticipated (such as in a vault), unless precautions are taken to prevent arcing.

In areas where fault currents or unusual risk of lightning may be anticipated, such as in close proximity to electrical transmission tower footings, the pipeline must be provided with protection from such currents as recommended by the Corrosion Technician and Manager of Engineering. These protective measures must also be taken at insulating devices, such as those at gate stations.

The protection from these fault currents shall typically be provided with the installation of a grounding cell (such as a Kirk Cell) or an isolator/surge protector. These devices act as an insulator (or isolator) at low DC voltages but conduct AC and high DC fault currents to ground to prevent potentially hazardous voltages from being developed on the pipeline.

Test Stations

The number and location of test points throughout a cathodic protection system shall be such that they provide sufficient data to determine the adequacy of cathodic protection. These test points are to be determined by, or under the direction of, a person qualified by experience and training in pipeline corrosion control methods. Test stations should allow sufficient access to the pipeline for all necessary tests including pipe-to-soil potentials, current flows and interference test.

VGS will install and maintain CP test stations to ensure all pipelines are adequately protected.

Spacing of test stations along the pipeline system will vary widely depending upon the type of soil, moisture, quality of pipe coating, size of pipe, type of cathodic protection system, level of cathodic protection, etc. With so many variables involved, the distance between test stations must be based on the judgment of a person qualified by experience and training in pipeline corrosion control methods for the specific installation and conditions.

As a rule of thumb VGS test stations should be located, on average, every one mile along the transmission system. Test stations will generally be located at road crossings so that they are accessible and can be maintained. Items that may prohibit test stations from the one mile average may include large farm fields, swamps, rivers and streams.

Test Station Location Requirements:

When designing new installations, test station leads must always be installed at the following locations:

- a. Pipe Casings
- b. Insulating Joints
- c. Galvanic Anode Installations
- d. Rectifier/impressed Current Anode Installations
- e. As Directed after Review by the Corrosion Technician

Casing Test Stations:

Any installation where steel carrier pipe is inserted into a steel casing requires a test station with leads from both the carrier pipe and casing. Casing test leads will be blue #8 -12 AWG wires and pipe test leads will be black #8 – 12 AWG wires.

Specific locations and use of stations shall be specified by the Corrosion Technician.

Two-Wire Test Station:

Two-wire test stations will contain 2 white AWG wires.

The Corrosion Technician shall specify locations and use of stations.

Four-Wire Test Stations:

Four-wire test stations are generally used to test the pipe on either side of an insulated coupling or other insulator. Black #8 – 10 AWG wires will be used on one side of the insulator; white #8 – 10 AWG wires will be used on the other.

The Corrosion Technician shall specify locations and use of stations.

Current Measuring Test Stations (IR Drop):

The Corrosion technician shall specify locations and use of stations.

Special Test Stations:

On occasion, specific situations may dictate the use of special test stations not outlined in the procedure. The arrangement and location will be specified by the Corrosion Technician for each special installation.

Test lead wires are required for various corrosion control testing and monitoring operations after pipe installation. Test wires must be securely attached to the pipe or structure and must be installed in the configuration recommended.

Connection to steel pipe or structures:

Connection of test wires to pipe or structures must be of such a nature as to maintain mechanical strength and electrical continuity.

The only acceptable method is the thermite connection.

Thermite Connection (Cadweld) - The thermite connection for STEEL should use ONLY 15 gram F-33 alloy charges. For #8 AWG - #12 AWG wire, use cartridge 15P. The powder is copper oxide and aluminum.

Thermite Welding of Wires:

USE CAUTION WHEN MAKING THERMITE CONNECTIONS NOT TO BREATHE ANY FUMES GENERATED DURING THE PROCESS.

Manufacturer's instructions should be consulted. The wire shall encircle the pipe at least once and then be knotted at the top pipe surface to provide a strain relief for the connection. The end of the wire to be attached shall be prepared as follows:

- a. For #10 AWG solid anode wire, approximately 3" of the end shall be stripped and the conductor doubled over to provide a 1 ½" connection end.
- b. For #8 AWG or #6 AWG copper test wire, approximately 1 ½" of the end shall be stripped and twisted tight and inserted into a copper sleeve supplied with the kit. Compress the sleeve so that it remains firmly on the wire. The thermite welder mold shall have a metal disk and a weld charge placed in the chamber. The mold shall be seated on the cleaned pipe surface, and the wire shall be inserted into the mold slot to its full depth. While the mold is held firmly in place, the charge is ignited and then allowed to cool approximately 15 seconds so the molten metal may solidify. After removal of the mold, the connection shall be tested for strength by striking it sharply with a hammer. After cooling, all cadwelds shall be coated with wax tape **or other approved coating methods.**

Recoating of Pipe and Wire at Thermite Connection:

For steel pipe, after the thermite weld has cooled sufficiently, prime and tape the weld and adjacent area to provide a coating of similar integrity and strength of mill-applied coating.

The following wire types will be used unless otherwise specified:

Galvanic Anodes shall be supplied with a Minimum #12 AWG solid copper wire with 600 Volt T.W. Type Insulation.

Test Wire: This will be #8 AWG solid copper wire with 600 Volt T.W. Type Insulation.

Minimizing Stress Concentration:

The test wires shall be securely tied around the pipe so that the connection point will not be affected by any undue stress on the wires and to minimize possible stress concentration on the pipe. Sufficient slack shall be allowed in the installation of all test wires.

Mechanical Connections:

In areas involving leak repairs where residual gas is present, a mechanical clamp may be substituted for a cadweld connection. This clamp will be designed specifically for the installation of a sacrificial anode.

Mechanical Splicing Connections:

Mechanical connectors shall be utilized to make wire-to- wire connections either in-line or branch. In-line connections shall be made with a water proof wire connector, while branch connections shall be made with a split-bolt connector. Split-bolt connectors allow branch connections from a header cable without cutting of the header cable itself, requiring only removal of insulation.

Impressed Current Systems:

Impressed current systems shall be utilized to protect large underground structures or distribution systems where stray currents on adjacent foreign structures would not be a serious problem. Ground bed design and rectifier selection are the responsibility of the VGS Corrosion Technician or corrosion consultant. Owners of adjacent underground metallic structures shall be notified before such systems are energized.

Galvanic Systems:

Design and layout of galvanic anode systems shall be the responsibility of the Corrosion Technician or corrosion consultants. Such systems are preferred for smaller sections of pipeline and in areas where stray currents generated by an impressed current system may cause serious damage to other underground metallic structures and where soil conditions permit with respect to resistivity of soil.

Installation of Anodes includes but is not limited to extra depth excavation, cadwelding, connecting, coating and wrapping, wetting, conduit, drip box, and terminal box. Do not connect anodes directly to the pipe under any circumstances, unless approved by the Corrosion Technician.

Efforts shall be made to install anodes parallel to the pipeline at least two (2) feet from the center of the pipeline, and at a distance of ten (10) foot centers when possible.

Anodes will be buried to an elevation of at least one (1) foot from the bottom of the pipeline to the top of the Anode.

Each anode wire lead will be connected to a collector cable (A.W.G. #8 solid copper with thin type insulation) which shall be installed parallel to the pipeline and over the Anodes. Connection to the cable to be made with split bolt copper connectors for #8 AWG - #12AWG. Connectors shall be wrapped.

Two main leads shall be attached to the pipeline by the cadweld method. One wire is #8 AWG and one wire is #12 AWG. The wires will be two (2) feet apart on the pipeline. The two main leads and collector cable will be terminated together in either a test box or

a post mounted terminal box.

When possible, wet the anodes before backfilling. Particular care must be taken in backfilling to ensure the wires are not severed, or damaged.

Insulated Fittings and Couplings

If the corrosion process is to be stopped, it is necessary to break the electrical path or continuity between the gas pipe and all metals cathodic to it. This is done by installing an insulation fitting between the metals. Insulating couplings, tees, flanges, and other insulating fittings are used to break the electrical path. The insulation fitting and the pipe adjacent to it must be well coated to eliminate exposure and a reverse coupling effect.

A. Coated steel pipe shall be insulated from the following structures:

1. Unprotected pipe
2. Bare steel pipe
3. Cast and ductile iron pipe
4. Copper pipe
5. District regulator vaults
6. Casings
7. House piping
8. All other pipelines or structures

B. The insulating end of insulating fitting shall go on the side towards the unprotected pipe.

C. A reasonable effort should be made to test insulating fittings after installation.

D. When non-insulating compression fittings are used, the pipe ends shall be thoroughly cleaned to bare metal to insure metallic contact with the fittings.

E. Steel man inserted into a casing shall have "insulators" installed.

Approved insulated fittings and couplings shall be used to electrically isolate new piping from old piping. Where new coated steel piping will be connected to either old bare steel or cast iron piping, an insulated fitting or coupling must be used. The Corrosion Technician shall have the responsibility of determining the need for an insulated fitting or coupling in all other applications. Insulated fittings and couplings shall be installed by closely following the manufacturer's directions.

Wire and Cable:

Wire and cable shall be suitable for the particular applications. Galvanic systems may utilize standard #8 AWG wire with THW grade insulation for all underground and above-

grade wiring. Impressed current systems may utilize #8 AWG wire with THW grade insulation for test wires or negative rectifier cable. However, cable attached to the positive rectifier terminal and used for direct burial in a ground bed shall be cathodic protection cable with High Molecular Weight Polyethylene (HMWPE) insulation. Actual cable size shall be determined by the Corrosion Technician for each installation.

Where underground wiring is to be direct-buried, the surrounding backfill shall be hand-shoveled, rock-free material. Minimum cover for underground wiring in a trench shall be 18". All wiring shall be inspected for damage to the insulation. Galvanic systems may have insulation repaired by taping with electrical tape. Impressed current systems shall not use any cable which, in the opinion of the Corrosion Technician, has excessive insulation damage. Where impressed current cable is deemed to be repairable, only resin type splice kits or cable sleeves that can be heat-shrunk shall be used to repair the defect.

Connections and Splices

Thermite Weld Connections:

Thermite weld connections shall be the preferred method of attaching cable or wire to underground steel pipes or structures. Refer to specific instructions regarding thermite welding procedures above. The thermite weld is a fusion weld of the conductor to the surface, using a special alloy with a minimum heat effect on the structure.

Mechanical Connections:

In areas involving leak repairs where residual gas is present, a mechanical clamp may be substituted for a cadweld connection. This clamp will be designed specifically for the installation of a sacrificial anode.

Splice Coating - Impressed Current Systems:

Connections in impressed current ground beds are susceptible to consumption if they are not sealed against the underground electrolyte, so specially manufactured splice kits are used on these connections. Two types of kits are available:

1. Resin Splice Kits. A pre-formed mold is snapped over the connection, and an epoxy resin is mixed and poured into the mold and allowed to harden and encapsulate the connection.
2. Fold-Over Splice Kits. A symmetrical sheet of elastomeric compound with a depression on each side. The connection is primed and depressed into the encapsulating gel on one side, while the other half is folded over to seal the connection.

Splice Coating - Galvanic Systems:

All splices shall be coated by one of two methods:

1. Immersed in mastic and allowed to dry.
2. Immersed in primer and allowed to dry; wrapped in electrical or cold-applied tape to cover.

Temporary installations:

Temporary installations are defined as those installations not to be in service for greater than five years beyond installation, need not be cathodically protected if corrosion on that pipeline during that five year period will not be detrimental to public safety.

Cathodic Protection Criteria

The criteria for cathodic protection and determination of measurements used by VGS are as described in 49 CFR 192 - Appendix D

DRAFT - NOT FOR CONSTRUCTION

VGS Operating Procedures	Corrosion Control – Protective Coating Effective Date: December 1, 2010 Page 1 of 2
---	--

Referring section:

192.461 – External corrosion control: Protective coating

192.483 – Remedial Measures – General

192.605 – Procedural Manual for Operations, Maintenance and Emergencies

See also following procedure:

Inspection

All steel line pipe used by VGS is to have an applied coating which meets the requirements of 192.461 and is specified and approved by the Engineering Department.

Properties required of external coatings:

Must be applied on a properly prepared surface per manufacturer's instructions for the coating being used.

The mill applied coating selected shall have low moisture absorption and high electrical resistance.

Just prior to lowering the pipe in the ditch and backfilling the coating must be jeeped and inspected.

Coating Repairs:

Repair of mill applied coating holidays and joint repairs must be of such a nature as to provide a coating of similar properties as the mill applied coating. The process to be followed is:

Cold-applied tape shall be installed using one of the two approved methods described below:

1. Spiral Wrapping. This method is recommended for use in extensive coating installations. Tape the area using an acceptable cold-applied tape using the spiral wrap method with 25% overlap and with an overlap onto the intact mill applied coating of at least 2". For this method the tape is spirally wound around the pipe, maintaining a minimum of ½" overlap between successive windings. A constant tension shall be applied to the tape to improve bonding and minimize bubbling.

VGS Operating Procedures	Corrosion Control – Protective Coating Effective Date: December 1, 2010 Page 2 of 2
---	--

2. Coating of Valves and Irregular Fittings:

Valves and irregular fittings should not be taped if taping will lead to voids under the tape. Instead, the following procedure is required:

- a. The pipe surface shall be cleaned of dirt, rust, scale or other contamination by using a file, wire brush, scraper or suitable solvent. Check any existing coatings for disbonding before mastic is applied
- b. Mastic shall be worked into the edges of the adjacent coatings and the pipe surface to assure proper bonding. The mastic shall be liberally applied. Follow manufacturer's instructions. Manufacturer's drying time for the mastic in use should be followed before backfilling. Appropriate personal protective equipment should be worn while when applying mastic.

DRAFT - NOT FOR CONSTRUCTION

VGS Operating Procedures	Cover Effective Date: April 13, 2012 Page 1 of 2
---	---

Referring sections:

192.303 – Compliance with Specifications or Standards

192.327 – Cover

192.361 – Service lines: Installation

See also following procedure: Casing

Transmission Lines

Except as provided below each buried transmission line must be installed with a minimum cover as follows:

Location	Normal soil	Consolidated rock
Class 1 locations	30 ”	18 ”
Class 2, 3, and 4 locations	36 ”	24 ”
Drainage ditches of public roads and railroad crossings	36 ”	24 ”

All pipe installed in a navigable river, stream, or harbor must be installed with a minimum cover of 48 inches in soil or 24 inches in consolidated rock between the top of the pipe and the underwater natural bottom (as determined by recognized and generally accepted practices). Consideration must be given when designing the pipeline to potential erosion in the river, stream, drainage channel, etc. If the potential for erosion exists, then the amount of cover shall be increased to reduce the chance of the pipeline being exposed in the future. An individual design for the crossing shall be completed by the Engineering Department in these cases.

Where an underground structure prevents the installation of a transmission line with the minimum cover, the transmission line may be installed with less cover if it is provided with additional protection to withstand anticipated external loads. The Engineering Department will determine what additional protection is needed for the particular location. Approval for less cover and additional protection shall be obtained from an operations department manager or supervisor.

VGS Operating Procedures	Cover Effective Date: April 13, 2012 Page 2 of 2
---	---

Distribution Mains

Each buried main must be installed with a minimum of 30 inches of cover (code requires 24 inches) with the following exceptions:

(a) Where an underground structure prevents the installation of a main with the minimum cover, the main may be installed with less cover if it is provided with additional protection to withstand anticipated external loads. Approval for less cover and additional protection shall be obtained from an operations department manager or supervisor.

(b) Road crossings shall be installed to a minimum depth of 36 inches. Approval for less cover and additional protection shall be obtained from an Operations Department Manager or Supervisor. See Casings Procedure for more information.

Depth of Service Lines

Services shall be installed with a minimum of 24 inches of cover to finished grade (code requires 12 inches). Where main depth or an underground structure prevents installation at the above depths, approval for less cover shall be obtained from an Operations Department Manager or Supervisor.

DRAFT - NOT FOR CONSTRUCTION

VGS Operating Procedures	Direct Burial Effective Date: April 1, 2013 Page 1 of 2
---	--

Referring sections:

192.303 – Compliance with specifications or standards

192.319 – Installation of pipe in a ditch

192.321 – Installation of plastic pipe

192.361 – Service lines: Installation

192.461 – External corrosion control: Protective coating

See also following procedures:

Excavation, Trenching and Backfilling

Pipe Installation - General

Underground Clearance

Direct Burial

1. Trench for pipe installation shall be wide enough to allow for installation of straight or coiled pipe without damaging the pipe and to allow for proper backfilling.
2. Minimum Cover shall be in accordance with the cover procedure.
3. Clean, suitable backfill material shall be used to pad and backfill around the pipe.
4. A Locator wire shall be placed according to the Locator Wire Procedure.
5. When possible to do so, yellow marking tape shall be installed approximately 12" below grade, over the pipe, as a warning.
6. A Minimum of 2" of temporary paving shall be used over the trench area where required or as required by the permitting agent.

Padding Materials

Where external protection against contacts is necessary, pads or shields may be installed as required. The following materials are approved for such use:

- a. rock-shield
- b. Neoprene rubber pads
- c. service protective sleeves
- d. fiberglass insulating sheets
- e. cradles cut from polyethylene piping

Installation of these materials will be made whenever the pipeline crosses in close proximity to another structure and a contact could occur through settlement or movement in the trench area. Protective materials and methods, other than those listed above, may be acceptable provided they are approved by the Engineering Department.

Lowering into Trench

Pipe being lowered into the trench shall be protected against damage to the pipe material or coating. Handling equipment, such as slings and calipers, shall be in good condition. Trench bottom and walls shall be checked for projections which could cause damage, and such projections shall be removed or provisions made to avoid contact. Vertically set skids or sandbags may be used to achieve alignment when lowering main into place. If skids are used they shall be removed once completed.

Plastic pipe used in direct-burial applications should be placed in the trench to allow for expansion and contraction. Twisting, stretching and kinking of plastic pipe shall be avoided when inserting into the trench.

Backfilling

Trench shall be backfilled according to the Excavation, Trenching and Backfilling Procedure.

VGS Operating Procedures	Excavation, Trenching and Backfilling Effective Date: April 13, 2012 Page 1 of 3
---	---

Referring Sections:

192.303 – Compliance with specifications or standards

192.319 – Installation of Pipe in a Ditch

192.361 – Service lines: Installation

Earth Excavation - General Safety

The area must be pre-marked and a DIGSAFE request must be called in prior to any excavating operations begin. Before excavating operations are begun, the site personnel must be satisfied that the location of underground facilities have been determined and properly marked.

Refer to the VGS Safety Standards for detailed specifics pertaining to VOSHA safety requirements on excavation and trenching safety.

Excavations must be properly safeguarded at all times until back filled. Appropriate signage and barricades must be used to alert pedestrians and vehicular traffic. Traffic control must be in accordance with MUTCD and/or Vermont AOT requirements.

On rare occasions, while excavating, soils contaminated with petroleum products or other chemicals may be discovered. In such situations work shall stop immediately. The Vermont Agency of Natural Resources should be contacted at 1-802-241-3876 and informed of the situation. The Vermont Agency of Natural Resources will provide guidance regarding what should, and should not, be done at the site. Work in the excavation shall not resume until the substances have been identified, and if necessary, applicable precautionary measures have been taken to protect the public and workers. If the uncovered contamination appears to present an obvious public hazard (flammable substance, etc.) the local fire department should also be contacted and advised of the situation. Contaminated soil shall not be removed or transported from the site unless advised or authorized to do so by the Vermont ANR/DEC.

Work shall not take place in excavations with potentially unsafe atmospheres unless personnel are using air monitoring equipment such as oxygen detectors. If the monitoring equipment indicates that a potentially unsafe atmosphere exists, employees shall exit the excavation immediately.

When the location of the excavation project is near trees or shrubbery care should be used in digging to avoid unnecessary injury to roots. Do not cut the roots of trees or shrubbery unless you obtain permission from a foreman or supervisor.

Disposal of Surplus Excavated Material

All material unsuitable for backfill, or any surplus excavated material not utilized within the limits of the project, shall be removed from the job site and disposed of in an

acceptable location and manner. If applicable, contaminated spoil shall be disposed of according to directions given by proper authorities.

Trench Requirements

The trench shall be excavated to the required width at the bottom and shall be deep enough to provide the required cover. The trench bottom shall be cut to a uniform grade across the entire width of the trench.

The trench shall be excavated as necessary to pass under pipelines, roadways, rail crossings, drainage ditches, canals, streams or other obstructions.

Prior to installation of the pipeline in the trench, the trench shall be inspected for rocks and debris either on the trench bottom or protruding from the trench wall. Such rocks and debris shall be removed from the trench.

Underground gas piping shall not be installed in a trench which contains, or is to contain, other structures or piping unless all Underground Clearance requirements are met.

Spoil Control

Where excavated material may interfere with traffic flow, it shall be removed from the site and stored until required for backfilling. Spoil left on-site shall be placed back 2 feet from the edge of the trench for safety.

Supports and Blocking

Supports shall be installed, as required, for other utilities crossing, or running parallel with, the trench. I-beams or wood bracing shall be used, with consideration given to the load to be supported. Supports shall be removed upon backfilling and satisfactory compaction around the supported structure.

Backfilling

The trench shall be backfilled as soon as practical after the pipeline is in place. The region within 6" alongside, below and on top of the pipeline shall be backfilled with padding sand or suitable backfill, free of cinders, ash and rocks. This material may be mechanically placed provided the required coverage around the pipeline is achieved. In no instance shall stone-bearing material be used as backfill around the pipeline. If satisfactory soil is not available from the excavated material, it may be secured elsewhere and transported to the jobsite. If necessary, the pipe should be wrapped with suitable rock-shield. Attach the rock-shield to the pipe with tape, place the fill around the pipe in a manner that will not damage the rock-shield or pipe, until the pipe is covered by 6 inches of fill. Rock-shield does not protect the pipe from high impact damage such as falling rocks from above the trench.

VGS Operating Procedures	Excavation, Trenching and Backfilling Effective Date: April 13, 2012 Page 3 of 3
---	---

Trench spoil material should be utilized for backfill material above the padding layer, whenever possible, within the confines of the project. . The material is acceptable provided rocks with a maximum diameter in excess of 6" are removed. However, organic material such as hay, mulch or sod shall not be mixed with the backfill because over time it will decompose resulting in settling. No excavated paving material shall be used in backfilling the trench. Marking tape shall be installed within 12" of finish grade for all pipelines that are installed by the means of open excavation. Marking tape is not utilized on pipelines which are installed by the means of boring or drilling.

Compaction - General

Fill in all voids under and on both sides of the pipe. Tamp fill over the pipe and along each side when the pipe is covered by at least 12 inches of fill. Mechanical tampers may be used only where there is no danger of damaging underground structures. Crossings with other structures shall be similarly compacted around and above the foreign structure. The back filling to grade should be done to minimize future settling. Puddling (using water alone to compact) shall not be used to compact the fill. Precautions shall be taken to prevent surface water from entering the ditch. Back filled areas must be left in a condition safe for vehicular and pedestrian traffic.

Compaction - In a Roadway

Follow the padding and tamping directions outlined above in "Compaction - General". Fill trench or hole within 18" from the top of road surface with the material taken from the road bed. Compact in 12 inch lifts. Replace any existing mirafied fabric. Backfill the last 18" with plant mix also compacted in 12 inch lifts, or to Town/City specifications. The asphalt road surface is cut 12 inches, or according to local town/city specifications, beyond the newly compacted material along each edge of the road cut.

DRAFT - NOT FOR CONSTRUCTION

VGS Operating Procedures	Fittings Effective Date: December 1, 2010 Page 1 of 2
---	--

Referring sections:

192.143 – Design of pipeline components: General

192.149 – Standard fittings

192.273 – Joining of materials other than by welding: General

192.303 – Compliance with Specifications or Standards

192.361 – Service lines: Installation

See also following procedure: Joints

Fittings

All fittings to be used in the transmission and distribution systems shall be rated to withstand the operating pressures for each application. In addition, all plastic fusion fittings shall be of compatible material for fusion to plastic piping in use.

Wall Thickness for Threaded Fittings and Nipples

The minimum wall thickness for steel threaded fittings and nipples is listed below for pipe diameter 3/4" through 2" and for pressure class ratings of 150, 300 and 600:

Pipe Diameter	Wall Thickness for ANSI Pressure Class			Thread Depth
	150	300	600	
3/4"	0.1205 in.	0.1271 in.	0.1379 in.	0.057 in.
1"	0.1320 in.	0.1459 in.	0.1594 in.	0.070 in.
1 1/4"	0.1343 in.	0.1509 in.	0.1680 in.	0.070 in.
1 1/2"	0.1359 in.	0.1545 in.	0.1741 in.	0.070 in.
2"	0.1389 in.	0.1617 in.	0.1861 in.	0.070 in.

Assuming pipe is grade B, 35,000 psi.

The minimum wall thickness was calculated using the design formula for steel pipe in section 192.105:

$$P=2SE(t-A)/D$$

The wall thickness is found by solving for t in the equation $t=PD/2SE + A$. An addition factor A is used for the allowance of corrosion, mechanical strength, mill tolerance, and

VGS Operating Procedures	Fittings Effective Date: December 1, 2010 Page 2 of 2
---	--

joint preparation for threaded fittings. The factor A is calculated by the following:

A = corrosion allowance + mill tolerance + thread depth

The corrosion allowance is 0.025 inches for gas pipe two inches and under. The mill tolerance is found by taking 12.5% of the nominal wall thickness. The thread depth is the depth of thread plus a tolerance of 0.015 inches.

Reference: Piping Handbook, sixth edition. Mohinder L. Nayyar, McGraw Hill 1992

Butt-weld Fittings

When using a butt-weld fitting, the fitting must have a pressure rating and a temperature rating appropriate for the application for which it is being used. The butt-weld fitting must also have a minimum wall thickness of the pipe it is being welded to.

Insulating Fittings

An insulating fitting will be installed at the main as close to the tap as possible in all coated steel services except:

Where the main is, or is proposed to be, under cathodic protection. The coating on the insulating fitting and on the pipe within about 2 feet of the insulating fitting is especially important. Inspect the coating carefully in this area for "holidays".

DRAFT - NOT FOR CONSTRUCTION

Referring sections:

192.303 – Compliance with specifications or standards

192.321 – Installation of plastic pipe

192.361 – Service lines: Installation

See also: Boring Procedure

This procedure defines the minimum requirements for pipeline construction by horizontal directional drilling (HDD) methods. HDD shall be performed in accordance with standard HDD industry practice and this procedure. .

References

Horizontal directional drilling operations shall be conducted in accordance with the following codes and standards, as applicable.

API (American Petroleum Institute)

13A Specification for Drilling Fluid Materials (1998)

13 B-1 Standard Procedure for Field Testing Water-Based Drilling Fluids (2008)

13 D Bulletin on Rheology of Oil-well Drilling Fluids (2010)

General

HDD shall include all labor, equipment and consumables necessary to accomplish the following:

- Mobilization to the site, including any and all applicable permits.
- Erection of horizontal drilling equipment at the drill site.
- Drilling of pilot hole along the alignment defined on Project Drawings.
- Reaming the pilot holes to a diameter suitable for installation of the prefabricated pull sections.
- Installation of the prefabricated pull sections within the reamed hole.
- Clean-up and restoration of all work areas upon completion of pipeline installation. (See Clean-up, Paving and Maintenance Procedure)
- Lay out the drill site and pipe make-up area and conduct operations to avoid damages to adjacent property, wetlands, riverbanks, stream banks, riparian habitat, adjacent concrete roads or sidewalks, and road pavement.
- Follow standard practices and local permits for traffic control and traffic safety.
- Pipe handling and pipeline welding. (See Welding Procedure)
- Corrosion coating of field joints. (See Corrosion Control – Protective Coating)

- Procedure)
- Disposal of excess drilling fluids.
 - Other general construction operations conducted in support of HDD operations.

Crossing Design

HDD Operator will verify the design of each crossing according to best industry practices and the equipment proposed for each crossing.

Pilot Hole

Surveying

The path of the pilot hole shall be continuously monitored by surface electronic location for alignment and depth during drilling.

Directional Tolerance

The pilot hole for entry and exit shall be along the path shown on the drawings. When entry and/or exit points are specified they shall be located to the tolerances listed below.

Entry point location: The pilot hole shall initially penetrate the ground surface at the location shown on the drawing unless otherwise approved by an Operations Manager.

Exit point location: The pilot hole shall finally penetrate the ground surface within plus or minus 3 feet of the alignment shown on the drawing and within plus 5 feet and minus 0 feet of the length shown on the drawing unless otherwise approved by an Operations Manager.

Alignment: Plus or minus 3 feet as long as it does not come within 3 feet of the right-of-way boundary and meets separation standards from all utilities and underground structures. See the Underground Clearance Procedure for more details.

In all cases, right-of-way restrictions shall take precedence over the listed tolerances. Regardless of the tolerance achieved, no pilot hole will be accepted if it will result in any or the entire pipeline being installed in violation of right-of-way restrictions.

In all cases, concern for adjacent utilities and/or structures shall take precedence over the listed tolerances. Listing of tolerances does not relieve the HDD Operator from responsibility for safe operations or damage to adjacent utilities and structures.

Curve Radius

For installation of steel pipe by HDD, the minimum radius of curvature shall be determined by the following:

$$R_{\text{curve}} = D \times 100$$

where

$$R_{\text{curve}} = \text{installed curve radius}$$
$$D = \text{pipe diameter}$$

The drilled radius shall be calculated using the following formula:

$$R_{\text{drilled}} = (L_{\text{drilled}} / A_{\text{avg}}) \times 57.3$$
$$R_{\text{drilled}} = \text{drilled radius over } L_{\text{drilled}}$$

where:

$$L_{\text{drilled}} = \text{length drilled}$$
$$A_{\text{avg}} = \text{change in angle over } L_{\text{drilled}}$$

Measurement of change in angle shall be taken at every 10 feet of length, drilled to ensure that the required minimum bend radius has been maintained along the total drilled curve.

See the Bends & Elbows Procedure for information on the bend radius for plastic pipe.

Ream and Pullback

Pre-reaming

Pre-reaming operations shall be conducted at the discretion of the HDD Operator. All provisions of this procedure relating to simultaneous reaming and pull back operations shall also pertain to Pre-reaming operations.

Pulling Loads

For installation of steel pipe by HDD, the maximum allowable tensile load imposed on the pull section shall be equal to 70% of the product of the specified minimum yield strength (SMYS) of the pipe and the area of the pipe section. The maximum allowable longitudinal stress (tensile + bending) shall be equal to or less than 90% of the SMYS.

For installation of HDPE pipe by HDD, the maximum allowable tensile load imposed on the pull section shall be as follows:

Table 1 – Allowable Tensile Loads for SDR 11 HDPE IPS Pipe Sizes							
HDPE Pipe Dimensions (inches)	3/4"	2"	4"	6"	8"	10"	12"
Outside Diameter (inches)	.875	2.375"	4.5"	6.625"	8.375"	10.75"	12.75"
HDPE safe pulling force in lbs., mid-range	378	1,831	6,732	14,591	24,730	38,416	54,041

To minimize over stressing HDPE pipe during installation by HDD, the Operator shall use a break-away swivels, specific to the SDR 11 pipe size and the allowable tensile loads. Swivels are to be installed between the pull string and the drill pipe.

Torsional Stress

A swivel shall be used to connect the pull section to the reaming assembly to minimize torsional stress imposed on the section.

Pull Section Support

The pull section shall be supported as it proceeds during pull back so that it moves freely and the pipe and corrosion coating are not damaged. Provisions will be made so the pull section does not unduly hinder adjacent property owners’ access to their property.

External Collapse Pressure

The pull section shall be installed in the reamed hole in such a manner that external pressures are minimized and the appropriate counter balancing internal pressure is maintained. Any damage to the pipe resulting from external pressure during installation shall be repaired or replaced.

Corrosion Coating Inspection on Steel Pipe

The pull section shall be inspected for holidays with a holiday detector as it enters the hole. Any coating damage found shall be repaired. Inspection and repair of corrosion coating shall be conducted in accordance with the Corrosion Control – Protective Coating Procedure.

Drilling Fluids

Composition

The composition of all drilling fluids to be used shall be submitted to an Operations Manager for approval prior to utilization. No fluid will be approved that does not comply with permit requirements and environmental regulations.

Recirculation

The HDD Operator shall maximize recirculation of drilling fluid surface returns. The Operations Department may specify standards for solids control and fluid cleaning equipment of a configuration and capacity that can process surface returns and produce drilling fluid suitable for reuse or for treatment of excess drilling fluid and drilled spoil.

Disposal

Disposal of drilling fluids shall be conducted in compliance with all relative environmental regulations, right-of-way and work space agreements, permit requirements, and use approved disposal sites.

Drill Site Housekeeping

Mud pits shall be suitably lined and bermed to prevent leakage to the surrounding area. All barrels, tanks, connections, valves, lines, etc. shall be maintained in good condition so that leaks do not occur. Should a leak occur, any spillage shall be cleaned up immediately and the cause of the leak remedied.

Inadvertent Drilling Fluid Returns

When drilling fluids inadvertently surface, the HDD Operator shall immediately ensure the fluids are cleaned up and shall, as appropriate, modify the drilling program so as to minimize any additional inadvertent fluid losses.

Protection of Underground Facilities

The HDD Operator shall ensure the following steps are undertaken prior to commencing with drilling operations:

- Contact DIGSAFE at least 48 hours prior to construction.
- Ensure all facilities in the area have been properly located and marked.

- Every effort shall be made to locate any sewer laterals in the area. If necessary, access to buildings in the area shall be sought to attempt to locate the exit point of sewer lines from the building. See the Locating Sewers Procedure??? For more details.
- Before commencing boring or drilling operations, the HDD Operator shall visually determine the subsurface horizontal and vertical location of parallel underground facilities within 3 feet of the designed alignment by exposing the facilities at frequent intervals. Any facilities to be crossed will be exposed at the crossing. Exposed facilities are to remain exposed until the pipeline is installed.
- Modify drilling practices & down hole assemblies to prevent damage to facilities.

Inspection of Pipe after Installation

The pipe shall be inspected after it is installed at the exit point to determine if there was any damage during pullback. If there is significant damage to the pipe keep pulling until there is no damage. Also the driller can dig back on the drill to determine if the cause of the damage is at the exit point. If undamaged pipe cannot be found within two rod lengths, then the entire drilling operation must be reviewed to ensure undamaged pipe on the redrill.

DRAFT - NOT FOR CONSTRUCTION

Referring section:

192.303 – Compliance with Specifications or Standards

192.627 – Tapping pipelines under pressure

See also following procedure:

Prevention of Accidental Ignition

Manufacturer's instructions shall be followed when using hot tap equipment. Only qualified personnel will make hot taps. The Prevention of Accidental Ignition Procedure will be followed when making hot taps.

DRAFT - NOT FOR CONSTRUCTION

DRAFT - NOT FOR CONSTRUCTION

VGS Operating Procedures	Inspection Effective Date: April 1, 2013 Page 1 of 3
---	---

Referring sections:

192.287 – Plastic pipe: Inspection of joints

192.305 – Inspection: General

192.307 – Inspection of materials

192.459 – External corrosion control: Buried or submerged pipelines installed before August 1, 1971

192.461 – External corrosion control: Protective coating

Visual Inspection

Pipelines under construction shall be visually inspected to assure that all applicable construction standards have been followed. Items to be checked shall include, but are not limited to:

- A. Apparent damage to pipe material (damage to PE pipe may not exceed 10% of the pipe's minimum wall thickness)
- B. Damage to factory coating of steel pipe
- C. Coating repairs and field coatings
- D. Welds and fusions
- E. Sufficient clearance from other structures
- F. Sufficient depth or cover
- G. Suitability of backfill material

All plastic pipe and fittings must be carefully inspected for any imperfections of manufacture as well as scratches, gouges, cuts, digs or any other damage that exceeds 10% of the wall thickness of the pipe. Heat fused joints must be visually inspected for adequacy and soundness. All personnel inspecting fused joints must be currently qualified on the joining procedure used to make the joint as well as all VGS Operator Qualification tasks relating to making and inspecting plastic pipe fusions. If there is any reason to believe the joint is defective, it shall be removed and replaced.

Holiday Detection

A holiday detector may be required on a particular project when requested by the Operations Department.

Weld/Fusion Tests

As required by regulations, or at the request of an Operations Department, welds or fusions shall be inspected or tested for flaws. The type and number of tests shall be determined by regulatory requirements, type of pipe material or number of flaws found

**VGS
Operating
Procedures**

**Inspection
Effective Date: April 1, 2013
Page 2 of 3**

under inspection, if any. Any inspection or test shall be conducted by personnel trained or experienced in carrying out such inspection or test. At all times that welding or cutting is occurring at a work site, a VGS employee in addition to the welder must be on site (outside of any excavation) to respond to any unusual circumstances

Radiographic Inspection

When required by an Operations Department, radiographic inspection of welded joints shall be employed to inspect for weld flaws that are detrimental to the serviceability of the steel main. API Standard 1104 shall be used for identification of detrimental flaws within weld joints. Radiographic inspection shall be performed by experienced personnel contracted by VGS for such service.

Other Tests

Where situations warrant use of tests not generally used for weld or fusion inspection, an operations manager or supervisor shall have responsibility for selection of test methods.

Inspection of Exposed Pipe

Whenever VGS piping is exposed and observed by personnel in the field, an inspection will be made of the condition of the pipe with regards to corrosion and, if coated, the condition of the coating. A report of these inspections will be made on a VGS Work Order in the Pipe Exposure Section. When coating is removed and bare metal is exposed, a C.P. Test reading shall be taken at the main or at the meter stop (when installing steel services). The C.P. test reading shall be documented on the install or maintenance work order. A copy of the reading shall be given to the Corrosion Technician for further investigation.

Electrical Coating Inspection (Jeeping):

All 2" or larger diameter pipe in a 40' or longer installation will be electrically "jeeped" before backfill, using an acceptable holiday detector set at the coating manufacturers recommended inspection voltage. All coating faults detected must be documented, marked and repaired.

- A. When gas mains, including the field applied coatings, need to be electrically tested for coating defects a holiday detector will be used. The manufacturer's instructions and NACE Standard RP0490-2001, Holiday Detection of Fusion-Bonded Epoxy External Pipeline Coatings of 250 to 760 μm (10 to 30 mils), Item 53074 must be followed for jeeping.

VGS Operating Procedures	Inspection Effective Date: April 1, 2013 Page 3 of 3
---	---

- B. Any holiday found will be immediately marked and repaired.
- C. No backfilling will be done until the holiday detection test is completed and all coating defects are repaired. A final holiday detection test will be performed over repaired holidays to assure coating damage was properly repaired.

DRAFT - NOT FOR CONSTRUCTION

Referring sections:

192.303 – Compliance with specifications or standards

INSTRUCTIONS (Preparation)

1. Ensure that all necessary underground utility locates have been provided (DigSafe).
2. Perform underground utility potholing prior to commencement of the HDD procedure to determine the subsurface horizontal and vertical location of parallel underground facilities within 3 feet of the designed alignment by exposing the facilities at frequent intervals. Any facilities to be crossed will be exposed at the crossing. Exposed facilities are to remain exposed until the pipeline is installed.
3. Ensure the location and depth of all buried utility and other underground structures within ten feet horizontally from the selected bore path.
4. Every effort shall be made to locate any sewer lines in the area. If necessary, access to buildings in the area shall be sought to attempt to locate the exit point of sewer lines from the building.
5. Determine the soil type to be bored.
6. Select a nearby site where the steel pipe can be constructed in one continuous length in preparation for the pull-in. Provisions will be made so the pull section does not unduly hinder adjacent property owners' access to their property.
7. All welding of steel gas piping must be performed by an individual currently qualified under section 5 of API 1104 or section IX of the ASME Boiler and Pressure Vessel Code.
8. Select the properly sized HDD machinery for the bore distance and steel pipe diameter.
9. Ensure that the steel pipe coating and weld joint coating wraps are of sufficient thickness to minimize the potential for damage during pull-in. Sacrificial coating, in addition to corrosion coating, may be used for protection during installation.
10. The entire steel pipe segment must be leak tested prior to pull-in according to provisions under 49 CFR Subpart J – Test Requirements.
11. Ensure that the leading end of the steel pipe is sealed to prevent the possibility of drilling fluid from entering the pipe

INSTRUCTIONS (General)

1. After all pre-reams have established an adequate bore hole for the pipe, ensure that the pipe is adequately protected from damage prior to and during the pull-in process.

For installation of steel pipe by HDD, the maximum allowable tensile load imposed on the pull section shall be equal to 70% of the product of the specified minimum yield strength (SMYS) of the pipe and the area of the pipe section. The maximum allowable longitudinal stress (tensile +

bending) shall be equal to or less than 90% of the SMYS.

A swivel shall be used to connect the pull section to the reaming assembly to minimize torsional stress imposed on the section.

2. Utilize roller stands and hoisting equipment to position the pipe segment into the bore hole.
3. Appropriate hoisting equipment should always be used to protect the pipe and coating.
4. Never drag the pipe segment along the ground.
5. The pull section shall be inspected for holidays with a holiday detector prior to pullback. Any coating damage found shall be repaired. Inspection and repair of corrosion coating shall be conducted in accordance with the Corrosion Control – Protective Coating Procedure.
6. If a bend must be used during the pull-in process, ensure that the bend is of a sufficiently long radius in order to avoid over stressing the pipe. Kinks in the pipe are not permitted.

For installation of steel pipe by HDD, the minimum radius of curvature shall be determined by the following:

$$R_{\text{curve}} = D \times 100$$

where

R_{curve} = installed curve radius

D = pipe diameter

The drilled radius shall be calculated using the following formula:

$$R_{\text{drilled}} = (L_{\text{drilled}} / A_{\text{avg}}) \times 57.3$$

R_{drilled} = drilled radius over L_{drilled}

where:

L_{drilled} = length drilled

A_{avg} = change in angle over L_{drilled}

Measurement of change in angle shall be taken at an interval equal to one drill rod length to ensure that the required minimum bend radius has been maintained along the total drilled curve.

7. The pipe shall be inspected after it is installed at the exit point to determine if there was any damage during pullback. If there is significant damage to the pipe keep pulling until there is no damage. The driller can dig back on the drill to determine if the cause of the damage is at the exit point. If undamaged pipe cannot be found within two rod lengths, the entire drilling operation must be reviewed to ensure undamaged pipe on the redrill.
8. After completion of the pull-in, a final leak test should be performed on the pipe segment prior to purging and final tie in to the existing gas system.
9. Utilize HDD location information to create a final set of plan and profile, (location and alignment), drawings of the pull-in.

DRAFT - NOT FOR CONSTRUCTION

VGS Operating Procedures	Permits, Easements and Rights of Way Effective Date: April 1, 2013 Page 1 of 1
---	---

Referring section:

192.303 – Compliance with specifications and standards

State Permits

For planned construction or maintenance work on any State Highway, a permit shall be secured before work may commence; in addition, the Vermont Department of Transportation (VTrans) shall be notified by telephone before work begins. A VTrans permit application form can be obtained at the VTrans office in Colchester or Saint Albans.

For emergency work on State highways, VTrans should be notified by telephone of the work and an application for permit shall be made as soon as practical upon completion.

Maintenance work, service replacement or service install work outside of the road way or not crossing the state highways requires a telephone notification only to the VTrans office in Colchester or Saint Albans.

Local Permits

Permits to allow construction or maintenance on local roadways shall be obtained as required by each individual city or town.

Easements

Whenever a proposed pipeline will pass through private property, an easement should be negotiated with the property owner prior to construction. The easement shall allow initial construction and subsequent maintenance of the pipeline and shall restrict erection of physical structures within the limits of the easement.

The Gas Control Department holds all of the existing VGS easements. Consult with them for any easement questions. If a new easement is needed for the construction of a new transmission/distribution main, service, or facility, make your request to the Gas Control Department.

Public Rights-of-Way

Distribution mains shall be installed within the public right-of-way as much as practical. State or local requirements shall be followed for occupancy of space in the public right-of-way.

<p style="text-align: center;">VGS Operating Procedures</p>	<p>Pigging – New Construction Effective Date: April 13, 2012 Page 1 of 1</p>
--	---

Referring section:

192.303 – Compliance with specifications or standards

Pigging

All newly constructed pipelines 2” in diameter or greater shall be cleaned of dirt, water, scale and other debris with an appropriate pigging device, which shall be forced through the pipeline, or its sections, with air pressure.

An acceptable pig-catching device shall be installed on the open end of the pipeline to prevent personal injury or property damage by the escaping debris or pig.

DRAFT - NOT FOR CONSTRUCTION

VGS Operating Procedures	Purging Effective Date: April 1, 2013 Page 1 of 14
---	---

Referring sections:

192.303 – Compliance with specifications or standards

192.629 – Purging of pipelines

Questions regarding purging or VGS Purging Procedures should be directed to the Operations Department.

VGS Purging Procedures

General Requirements

Purging can be defined as the replacement of one gas by another in an enclosed space (a pipe). Purging can take place in two ways, displacement or dilution. Most purging operations are a combination of the two ways with some dilution taking place while the displacement operation is being carried out. At Vermont Gas, purging is either replacing natural gas with air or nitrogen or replacing air with natural gas. The major safety consideration for any purging procedure is to prevent or minimize the creation of an explosive mixture of gas within the pipeline. This can be accomplished by; (1) purging natural gas with an inert gas like nitrogen to avoid adding gas that will create an explosive mixture, (2) use a slug of nitrogen between the air and the natural gas to prevent mixing of the air and natural gas, or (3) minimize the mixing of air and natural gas by purging at a velocity high enough to create turbulent flow within the pipe.

Whatever method of purging is used, during purging operations, it is important to keep a high rate of flow of the purge gas to minimize mixing of the purge gas and the gas being purged. The purge gas must flow through the pipe at a minimum rate of 100 linear feet per minute to create the turbulent flow required to minimize mixing. Purge rates between 100 and 200 feet per minute are recommended. Any interruptions or slowing of the purge gas injection rate should be avoided. Remember, in any purge operation, it is better to purge too much rather than not enough.

****NOTE:** These procedures have been developed, in part, from the American Gas Association: "Purging Principles and Practices". Third Edition 2001

Isolation

Whenever any pipeline is to be purged, it is essential to isolate it from the rest of the system by blocking or cutting all its connections. This will: (1) prevent air from entering while the line is being gassed or prevent purge gas from escaping while the pipeline is being purged and (2) prevent air from entering the pipeline once it is purged in or out of service.

VGS Operating Procedures	Purging Effective Date: April 1, 2013 Page 2 of 14
---	---

Disposal of Purge Gasses

Venting large volumes of combustible gas into the atmosphere should be minimized where practical. It may be necessary to discharge large volumes of combustible gas into the atmosphere, so it is important that the combustible gas be vented into the air without hazard to VGS employees, the public or property. Vertical vent stacks with a valve of sufficient height and capacity will be required to provide safe control. Any nearby buildings, overhead power lines or other potential sources of ignition should be considered when selecting the location of these vent pipes. Also, the noise and odor of the venting procedure must be considered when locating vent pipes. If noise will be a problem, noise suppressors may be used.

Communications

Radio or other voice communication shall be established between both ends of the pipeline to be purged. Communication shall be maintained during the entire purging procedure.

Before purging begins, notify the dispatcher (during normal working hours) or Gas Control (after normal working hours) if necessary. The dispatcher shall notify other Company Personnel and appropriate municipal agencies as directed.

As the conditions warrant, a Field Service Technician should be requested to check pilots and otherwise monitor for adequate pressure to serve customers in the immediate vicinity of the purge.

Safety and Potentially Combustible Atmospheres

All sources of ignition (e.g., transformers, electrical cords, open flames, company vehicles, etc.) shall be removed or neutralized from the immediate vicinity of the vent stack or other areas where combustible gas may escape during the purge. Refer to Prevention of Accidental Ignition Procedure.

Purge gasses shall not be released near any open windows, doors, equipment air intakes, etc.

An electrical ground wire must be installed between the vent pipe and the pipeline.

A Combustible Gas Indicator that has been checked for calibration within the past 30 days shall be used to sample gas at the vent stack.

VGS Operating Procedures	Purging Effective Date: April 1, 2013 Page 3 of 14
---	---

A fire extinguisher shall be placed at a readily accessible location at both ends of the pipe to be purged.

Flame retardant coveralls shall be worn by the person(s) sampling purged gas and by the person controlling the vent stack valve(s) when explosive levels of natural gas will be expected to exist.

Appropriate personal protective equipment such as gloves, hearing and eye protection shall also be utilized.

The area should be monitored for methane and oxygen levels. If increased combustibility levels or decreased oxygen levels are noted purging should be stopped and the process re-evaluated.

Venting

General

The purpose of a vent pipe is to carry the purged gas from the end of the pipe being purged to a point of safety above the heads of workers, the public and property. A vent pipe 6 to 10 feet above ground height will generally work. If ignition of a flammable mixture is to occur during a purging operation, it will most likely occur at the point of exit at the vent. If ignition does occur at the vent pipe, it is important that the flashback does not travel into the pipeline. For this reason, the velocity of the gas in the vent pipe must be higher than the velocity of the gas in the pipeline. To safely prevent flashback within the vent pipe, the gas must travel through the vent stack at a velocity greater than 10 linear feet per second. The diameter of the vent pipe is important in determining the exit velocity of the purged gas. Sizing the vent pipe smaller than the pipe being purged will assure the velocity of the gas in the vent will be faster than the velocity of the gas in the pipe. Several vent pipes (properly sized) may be needed to completely vent a section of pipe to be purged. Vent pipes are usually placed at drip risers, high points in the line and at the outlet end of the pipe to be purged. (See Table 1 for maximum vent size for each pipe size). As gas travels through the vent pipe, static electricity will build up within the walls of the pipe. A discharge of this static electricity could cause ignition of the purge gas. For this reason, the vent pipe should always be grounded.

VGS Operating Procedures	Purging Effective Date: April 1, 2013 Page 4 of 14
---	---

Pipelines not Required to Have Vents

In most cases, the following sizes and lengths of pipeline will not require the use of a vent stack. On services, insure that the meter or riser valve is shut off and plugged or capped before the main is tapped out and gas enters the service line.

PIPELINES NOT REQUIRED TO HAVE VENTS WHILE PURGING

PIPE DIAMETER (INCHES)	MAX. LENGTH OF PIPE (FEET)
SERVICES SMALLER THAN 2"	--
ANY PIPE - 2 INCH	50 FEET
ANY PIPE - 3 INCH	45 FEET
ANY PIPE - 4 INCH	40 FEET

Note: In some situations, location and/or topography may warrant use of a vent stack, even if one is not required by this guideline. Consult with the Supervisor of Maintenance in such cases.

If a vent is not used, the area in which the gas is to be released shall be open and well ventilated, it shall be barricaded and all sources of ignition shall be removed or eliminated.

Purging Natural Gas With Air or Nitrogen

General

During purging, air introduced into a pipeline containing combustible gas forms a short length of gas mixture within the flammable range. To minimize mixing, the purge medium (nitrogen or air) should be introduced at a high enough velocity to create a turbulent flow at the interface between the purge medium and the gas. A velocity of at least 100 linear feet per minute should be satisfactory for a minimum of mixing in all sizes of pipe. Such mixing as may take place varies with the length and size of pipeline. Since the pipeline is completely enclosed when the purging operation occurs, the only possible ignition of the mixture would be from within by some source such as solid particles or static electricity.

A slow purge of less than 100 linear feet per minute may permit excessive mixing and stratification of air and combustible gas, and should be avoided. The greater the velocity, the greater the turbulence and, therefore, less chance of creating a long section of air-combustible gas mixture.

Purging Small Diameter Pipe -Smaller than 4 inch

Pipelines smaller than 4 inches in diameter can be purged by direct displacement of combustible gas with air without creating a flammable mixture of significant length during the purge. All parts of the piping system must be purged completely and combustible gas vented to the atmosphere must be discharged safely. Purging should progress with as little interruptions as practical. The configuration of the piping system determines the number and locations of points where combustible gas should be vented. If lengthy and/or complex pipeline systems must be purged, the Supervisor of Maintenance should be consulted when determining where to place vent stacks. Possible ignition sources will be eliminated where combustible gas is vented to the atmosphere. NOTE: To ensure a greater margin of safety, any segment of 4 inch pipeline that is greater than 500 feet in length shall only be purged of combustible gas using either of these methods:

- a) Purge by Complete Filling with Nitrogen
- b) Purge using a nitrogen slug.

Large Diameter Pipe - 4 Inch and Greater in Diameter

As pipe diameter increases, the length of flammable mixture increases and it becomes a more important consideration during purging operations.

Pipelines 4" and greater in diameter shall be purged out of service by either of these methods.

- a) Purge by complete filling with Nitrogen.
- b) Purge by nitrogen slug to separate gasses.

All pipelines 4" in diameter or greater should be purged by complete filling with nitrogen, except in cases where the size and length of the segment would call for unreasonable quantities of nitrogen. In such cases, methods utilizing a nitrogen slug or air movers should be used.

Purging Natural Gas with Air or Nitrogen

This procedure may be used to purge natural gas with air or nitrogen. Injection of nitrogen or air must be through 50 feet of 3/4" hose with a pressure gauge at the inlet end of the hose.

- (1) Install a vent stack no larger than the maximum vent size indicated on Table 1.
- (2) Determine pipeline diameter and the length of the section to be purged.
- (3) Using Table 1, determine the appropriate air or nitrogen injection rate and pressure.
- (4) Determine the volume of nitrogen required to complete the purge. Use Table 2 to find how much nitrogen to use in the purge. Table 2 will provide a volume of at least 1 1/2 times the actual volume of the pipe. Assume a tank of Nitrogen at 2400 psi contains 250 cubic feet of usable gas.
- (5) Open the vent valve at the downstream end of the section being purged. Downstream vent valves should always be opened fully when they are opened.
- (6) Start purging by bringing the injection rate quickly to the determined pressure and maintain this pressure until the purge is complete.
- (7) Verify the completeness of the purge by using a combustible gas indicator.
- (8) Close the vent valve.

TABLE 1
Inlet pressure required to achieve purge flow rates
Injecting air or nitrogen

PIPE SIZE	4"	6"	8"	10"	12"	16"
INJECTION RATE	11 CFM	29 CFM	56 CFM	96 CFM	149 CFM	273 CFM
INJECTION PRESS.	3 psi	8 psi	14psi	27 psi	47 psi	27 psi
MAXIMUM VENT SIZE	2 "	4"	4"	4"	6"	6"

NOTE: These injection rates and pressures are for use with 50 feet of 3/4" hose for 12 inch pipe and smaller and 50 feet of 1 1/4" hose for 16 inch pipe and bigger. These should provide an injection rate of about 200 linear feet per minute. The pressure gauge must be located at the inlet end of the hose. Flow through the hose has been calculated such that at the pressure given, the required flow rate will be achieved. Vent size is to achieve a minimum of 10 cubic feet per second velocity from the vent. The data in this table are based on information from Chapters 1 & 8 of PURGING PRINCIPLES AND PRACTICE, an American Gas Association Operation Section Report.

TABLE 2
Volume of nitrogen required to purge a pipeline by complete filling with nitrogen

PIPE SIZE	PIPE LENGTH			
	100 ft	500 ft	1000 ft	2000 ft
2 INCH	4 cu. ft.	16 cu. ft.	33 cu. ft.	66 cu. ft.
4 INCH	13.5 cu. ft.	67 cu. ft.	135 cu. ft.	270 cu. ft.
6 INCH	33 cu. ft.	165 cu. ft.	330 cu. ft.	660 cu. ft.
8 INCH	55 cu. ft.	275 cu. ft.	550 cu. ft.	1110 cu. ft.
10 INCH	87 cu. ft.	435 cu. ft.	870 cu. ft.	1740 cu. ft.
12 INCH	125 cu. ft.	625 cu. ft.	1250 cu. ft.	2500 cu. ft.
16 INCH	200 cu. ft.	1000 cu. ft.	2000 cu. ft.	3900 cu. ft.

NOTE: Volumes indicated are volume of pipeline plus 50%. For pipelines longer than 2000 feet, add the above increments until the correct length is achieved. Assume the usable volume of gas in each bottle is 250 cubic feet at 2400 psi.

Purging Large Diameter Pipe with Air Movers

Air movers are essentially portable ventilating devices that have no moving parts. Air movers work by converting the pressure of compressed air into an induced draft by producing a venturi effect. This venturi effect causes the atmosphere being moved to be drawn through the bell of the air mover.

Air movers are installed on blowoffs or vent stacks on each end of a pipeline to be evacuated. A cold cut can then be made on the pipe between the air movers. When the air movers are operated, air is drawn into the pipe through the cold cut toward either end. Welding and repair operations can then be safely performed on the pipe.

A constant supply of compressed air must be maintained to keep the air movers working.

Purging natural gas with one Air Mover

This procedure may be used to purge natural gas from a large diameter pipeline. The air mover will draw air from one end of the pipe to the other using compressed air as the

energy source. Vermont Gas owns two TX3AM air movers made by Texas Pneumatic Tools. The TX3AM is 3 inches in diameter.

- (1) Install vent stacks on both ends of the main being purged. The vent stack must have a valve in it and the vent stacks must be at least 3 inches in diameter for the 3 inch air movers to work correctly.
- (2) Install the air mover on top of the vent stack at the outlet end of the pipe being vented. Natural gas will be drawn to this end.
- (3) Attach a ground wire from the air mover to the vent stack and earth ground.
- (4) Connect the air mover to the compressor using a 1 ½" inch compressor hose. There must be a 0-100 psig gauge on the hose at the air mover to measure the air pressure going into the air mover.
- (5) When ready to begin the purge, open the valves on both vent stacks and any valves on the pipe being purged. Open the valve at the air compressor allowing air to flow to the air mover. Regulate the air compressor pressure to obtain the desired pressure at the air mover. See Table 3 for correct air pressure at the air mover.
- (6) With a combustible gas indicator, periodically check the gas coming out of the air mover until there no detectible natural gas.

Purging natural gas from a pipeline with 2 air movers

This procedure is appropriate for purging a pipeline for repairs. The air movers are installed at both ends of the pipeline to be repaired. Air is drawn into the pipeline through a cold cut made in the pipe between the air movers. Repairs can safely be made on the pipe with the air movers operating.

- (1) Install vent stacks on both ends of the main being purged. Install an air mover on top of each vent stack.
- (2) Install a ground wire from the air movers to the vent stacks and earth ground.
- (3) Connect the air movers to the compressors using 1 ½" compressor hose. There must be a 0-100 psig pressure gauge installed on the air hose at the air movers to monitor air pressure going into the air movers.
- (4) When ready to begin the purge, open the valves on both vent stacks and any valves on the pipe being purged. Open the valves at the air compressors allowing air to flow to the air movers. Regulate the air compressor pressure to obtain the desired pressure at the air movers. See Table 3 for correct air pressure at the air mover.
- 5) With a combustible gas indicator, periodically check the gas coming out of the air movers until there is no detectible natural gas.

TABLE 3
Total air flow and air consumed at various air pressures for
Texas Pneumatic TX3AM air movers

	INLET PRESSURE		
	40 PSIG	60 PSIG	80 PSIG
total air flow	1017 cfm	1231 cfm	1462 cfm
air consumed	35 scfm	45 scfm	61 scfm
air induction ratio	29.06	27.36	23.58

NOTE: Data for TABLE 3 is from Texas Pneumatic Tools, Inc. published usage information for TX3AM Air Mover.

Purging Air with Natural Gas

General

Pipelines smaller than 4 inches in diameter can be purged into service by direct displacement of air with natural gas without creating a flammable mixture of significant length during the purge. All parts of the pipeline must be purged completely and combustible gas vented to atmosphere must be discharged safely.

For pipe diameters 4" and greater, care must be taken to limit the amount of flammable mixture of gas created within the pipe. During purging, combustible gas introduced directly and rapidly into a pipeline containing air forms a short length of gas mixture within the flammable range. To minimize mixing, two methods are recommended. The natural gas can be introduced at a high enough velocity to create turbulent flow within the pipe at the interface between the gas and the air. An alternative method is to inject a slug of nitrogen before injecting the natural gas (see following section). The nitrogen will separate the air and natural gas and prevent a combustible mixture from forming. With either method, the nitrogen and natural gas must be introduced at a velocity of at least 100 linear feet per minute to create turbulent flow and minimize mixing.

Displacing Air with Natural Gas in pipelines smaller than 4 inch in diameter

- (1) Determine pipeline diameter and length of section to be gassed.
- (2) Make the tie-in of the pipe in service with the section of pipe to be purged with a valve, squeeze-off, or stopper fitting between the live section and the section of pipe to be gassed.

- (3) Install a vent at the downstream end of the pipe being gassed. Open the vent valve. Downstream vent valves should always be opened fully when they are opened.
- (4) Start gassing by opening the valve, squeeze-off or stopper fitting between the two sections of pipe. Open the valve slowly but open it enough to get a good flow of gas into the pipe.
- (5) Use a combustible gas indicator at the vent stack to verify the completeness of the gassing operation. The use of a combustible gas indicator provides a means of analyzing the gas-air mixture throughout the gassing operation and also of confirming the gas to be free of air.
- (6) Close the vent valve and allow the pressure in the two sections of pipe to equalize.

Inlet Control Method for Replacing Air with Natural Gas

Large diameter pipes (4 inch in diameter and greater) may be purged into service using the Inlet Control Method. This method may be used when using a nitrogen slug is impractical. It is important to maintain a flow velocity of at least 100 linear feet per minute. The combustible gas flow must be continued without interruptions until the vented combustible gas is free from air. For more information about this method of purging, see section 8.55 of AGA Purging Principles and Practice. For this procedure to work, the pipe being gassed must be of known size and length, it must be dry and there must be a connection for a pressure gauge at the inlet end of the section to be purged.

When using the inlet control method on the transmission lines and there is a remote operated main line valve (MLV) in line for controlling the pressure the utilization of the blow down stacks with a hose will be used instead of the MLV. A 50' $\frac{3}{4}$ " hose for pipe 12" and under or a 50' $1\frac{1}{4}$ " hose for pipe 16" and up with an upstream gauge will be installed between the two blow down stacks in order to control the inlet pressure to the pipe section being purge of air.

Inlet Control Method for directly purging air with natural gas in large diameter pipes

- (1) Make the tie-in of the live section of pipe to the section of pipe being purged with a valve, squeeze-off or stopper fitting between the two sections of pipe.
- (2) Determine the vent size, pipeline size, and the length of the section to be gassed.
- (3) Determine the inlet control pressure from Table 4.
- (4) On the pipeline to be gassed, install as close as possible to the inlet control valve (not more than 10 feet away), a pressure gauge, which is accurate and readable to within 1 psi, so that the inlet pressure can be observed. (Note: the gauge should be connected through several feet of flexible tubing to eliminate excessive vibration.)
- (5) Open the vent valve at the downstream end of the section to be gassed. Downstream vent valves should always be opened to the fully open position.
- (6) Start gassing by slowly opening the valve, squeeze-off or stopper fitting and bringing the inlet pressure quickly to the determined pressure and maintain the pressure until 100% combustible gas is at the vent stack. Use a combustible gas indicator to measure

VGS Operating Procedures	Purging Effective Date: April 1, 2013 Page 11 of 14
---	--

the gas at the vent stack. It should take approximately 2 minutes per mile to gas the pipe.

(7) When the Combustible Gas Indicator reads 100% gas, close the vent valve.

DRAFT - NOT FOR CONSTRUCTION

TABLE 4
Purging data for inlet control procedures
Minimum Inlet Pressures - PSIG
(By Pipeline Size)

length of pipe (miles)	2" Vent Valve		4" Vent Valve				6" Vent Valve		Pipe Size
	4"	6"	6"	8"	10"	12"	12"	16"	
1	6	9	3	3	3	5	2	3	inlet
2	12	13	7	5	5	7	3	4	pressure
3	18	17	10	7	7	8	5	5	(PSIG)
4	24	21	13	10	9	10	6	6	

NOTE: Establish pressure from this table and maintain the pressure for a total time equal to 2 minutes per mile of pipeline.

EXAMPLE: A 2 mile section of 6" pipeline is to be purged into service using the Inlet Control Method. A 4-inch vent is to be used. From Table 4, the inlet pressure should be 7 psig and the procedure should take approximately 4 minutes.

Purge using Nitrogen Slug to Separate Gasses

General

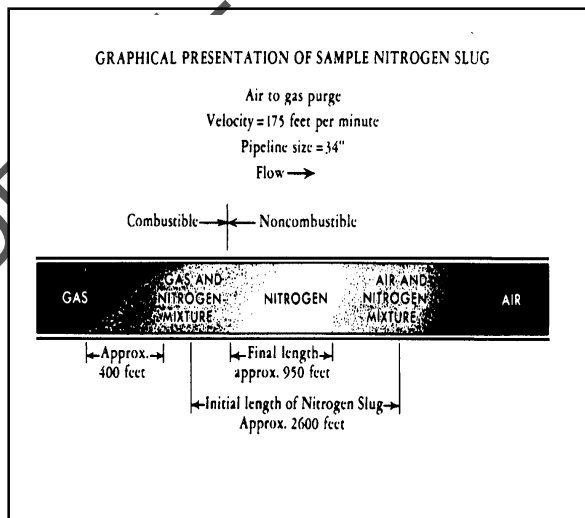

Formation of flammable mixtures during purging can be prevented with inert gas without filling the entire length of the isolated section of pipe with the inert gas. This is accomplished by maintaining a quantity of inert gas, known as a slug, between the air and the combustible gas while the pipeline is being purged. The slug must be long enough to allow for shortening by reason of mixing with air and combustible gas at each end of the slug. If the purge cannot immediately follow the insertion of

the inert gas slug because of unforeseen delay, additional inert gas must be inserted and an entirely new slug established. Precautions should be taken to avoid damage to high strength pipe by sudden temperature changes caused by rapid introduction of purge gas.

These two procedures should be utilized when the size and length of pipeline segment makes a purge by complete filling with nitrogen unfeasible.

Replacement of Air with Natural Gas using a Nitrogen Slug

Use this method to replace air with natural gas in a newly installed segment of pipeline using a nitrogen slug to prevent the formation of a flammable mixture. This procedure is the Inlet Control Method of gassing a pipeline (see section 4) with a nitrogen slug between the air and the natural gas.

- (1) Determine the diameter and length of pipe being purged. At the downstream end, install a vent stack no larger in diameter than the maximum vent size indicated in Table 1.
- (2) Make the tie-in of the live section of pipe to the section of pipe being purged with a valve, squeeze-off or stopper fitting between the two sections of pipe.
- (3) Install temporary connection to inject nitrogen into the new section of pipe. Use 50' of 3/4" hose to connect the nitrogen bottles to the injection fitting. Install a pressure gauge at the inlet of the 3/4" hose. Install a pressure gauge at the outlet end of the hose to use when injecting natural gas.
- (4) Fully open the downstream vent valve. Vent valves should always be opened fully when they are opened.
- (5) Using Table 5, determine the appropriate injection rate and find out how much nitrogen will be needed for the slug.
- (6) Start purging by bringing the injection pressure quickly to the determined pressure and maintain the pressure until the appropriate amount of nitrogen (from Table 5) has been injected. To determine how much nitrogen has been injected, multiply the appropriate rate from Table 5 by the amount of time the purge has been in progress.
Example: The injection rate is to be 20 cfm(cubic feet per minute) and you need to inject 20 cubic feet: open the valve until the gauge reads 5 psi and inject nitrogen for 1 minute.
- (7) When enough nitrogen has been injected, begin purging the pipeline by opening the valve, stopper fitting or squeeze-off between the live section of pipe and the new section of pipe. Close the nitrogen tank valves at the manifold or the tank as the bypass valve, squeeze-off or stopper fitting is opened. Bring the inlet pressure quickly to the determined pressure and maintain the pressure until 100% combustible gas is measured at the vent stack with a combustible gas indicator. The gassing operation should take about 2 minutes per mile of pipeline.
- (8) Close vent valve.

Replacement of Natural Gas with Air using a Nitrogen Slug (see preceding figure)

Use this method to replace natural gas with air utilizing nitrogen as a slug to prevent formation of a flammable mixture.

- (1) Determine the diameter and length of pipe being purged. At the downstream end, install a vent stack no larger in diameter than the maximum vent size indicated in Table 1.
- (2) Install connection to inject nitrogen and air.
- (3) Isolate the pipe segment to be purged; blow down pipe to atmospheric pressure and leave vent stack open.
- (4) Using Table 5, determine the appropriate injection rate and pressure and find out how much nitrogen to use as a slug.
- (5) Start purging by bringing the injection pressure quickly to the determined pressure and maintain the pressure until the appropriate amount of nitrogen (from Table 5) has been injected. To determine how much nitrogen has been injected, multiply the appropriate rate from the table by the amount of time the purge has been in progress.
 Example: The injection rate is to be 20 cfm (cubic feet per minute) and you need to inject 20 cubic feet: open the valve until the gauge reads 5 psi and inject nitrogen for 1 minute.
- (6) Inject air immediately following the nitrogen, maintain the appropriate injection pressure. Close the nitrogen manifold as the air valve is opened.
- (7) Stop injection of air when Combustible Gas Indicator at vent indicates approximately zero percent gas.
- (8) Close the vent valve.

TABLE 5
Volume of nitrogen to be used for nitrogen slug

Pipe Size	Injection Rate	Injection Pressure	cubic feet of Nitrogen per length of Pipeline					
			500'	1000'	2000'	5000'	10,000'	20,000'
4"	11 cfm	4 psi	19	23	29	40	53	71
6"	29 cfm	8 psi	46	56	70	98	129	173
8"	56 cfm	17 psi	77	94	117	164	217	291
10"	96 cfm	34 psi	121	147	184	257	340	457
12"	149 cfm	59 psi	173	14721 1	263	368	486	653
16"	273 cfm	26 psi	280	342	430	605	802	1080

VGS Operating Procedures	Purging Effective Date: April 1, 2013 Page 15 of 14
---	--

NOTE: These injection rates and pressures are for use with 3/4" hoses 50 feet in length for 12 inch pipe and smaller and 50 feet of 1 1/4" hose for 16 inch pipe and bigger. The data in this table are from Chapter 8 of PURGING PRINCIPLES AND PRACTICE (Third Edition) an American Gas Association Operation Section Report.

DRAFT - NOT FOR CONSTRUCTION

DRAFT - NOT FOR CONSTRUCTION

Referring sections:

192.309 – Repair of Steel Pipe

192.703 – Maintenance – General

192.711 – Transmission lines: Requirements for repair procedures

192.713 – Transmission lines: Permanent field repair of imperfections and damages

192.715 – Transmission lines: Permanent field repair of welds

192.717 – Transmission lines: Permanent field repair of leaks

See also following procedures:

Purging

Stop-offs and By-passing

Welding

Damaged Steel Pipe

If the pipe ends are damaged such that a satisfactory alignment for welding cannot be obtained, the pipe shall be cut and beveled. Dents, gouges or faulty welds on pipe that is in service may be repaired by mechanical or welded full encirclement sleeves. In new pipe or in situations where full encirclement sleeves are not feasible, any dent, gouge or faulty weld in a pipe wall determined to be detrimental to its serviceability shall be removed from the pipe as a cylinder containing the defect. (Refer to Welding Procedure.)

Mechanical Steel Pipe Repairs

If welding cannot be done on the distribution system in a timely manner to make the necessary repairs to place the pipe back in service, temporary mechanical couplings and a section of pipe or caps can be installed per manufacturer's recommendations. A permanent repair of a leak will be made as soon as it is practical to do so.

Service lines 2" and smaller, which will be replaced will not be required to have strapping for the couplings installed during this temporary period unless they are within 15' of an elbow.

All couplings on mains will be protected from separation of the pipe by means of a full encirclement sleeve where feasible. If not feasible, strapping will be installed.

Mechanical couplings 2" and smaller will require one strap a minimum of 1" wide, 1/4" thick, and 4 inches of the strap welded to the pipe on either side of the coupling. 4" couplings will be required to have two straps evenly placed on the pipe with the same design requirements as the 2" coupling. 6" & 8" couplings will be required to have three straps evenly placed on the pipe with the same design requirements as the 2" coupling. 10" & 12" couplings will be required to have four straps evenly placed on the pipe with the same design requirements as the 2" coupling.

Mechanical end caps 4" and smaller require two straps a minimum of 1" wide, ¼" thick, 4 inches of the strap welded to the pipe, and the other end welded to the front of the cap. 6" & 8" end caps will be required to have three straps evenly placed on the pipe and cap with the same design requirements as above. 10" & 12" end caps will be required to have four straps evenly placed on the pipe and the cap with the same design requirements as above.

Existing 4" and larger mechanical couplings being repaired on mains or services will be required to be strapped after repairs are completed. The strap requirements are the same as above for a temporary repair. Existing 2" and smaller mechanical couplings will be repaired and then a weld encirclement sleeve will be placed over the coupling for a permanent repair.

2" and smaller Insulated Compression Couplings will be the exception if the Corrosion Technician requires the Insulated Compression Coupling for a control point. When installing reinforcement straps over Insulated Compression Couplings, the 5/8" reinforcement straps will need to be insulated from the pipe to maintain the control point.

Repair by Pipe Replacement - Medium Pressure Coated Steel

If it is determined the section of pipe is excessively corroded or dented or damaged beyond repair, the damaged section of pipe must be replaced or removed from service.

1. Excavate along the pipe until undamaged pipe is visible on both sides of the damaged area.
2. Determine the location of the nearest sectionalizing valves needed to isolate the area from the system and if the area can be isolated using existing valves or if an approved stopper fitting must be installed. Refer to Vermont Gas Systems' Stop-off and By-passing Procedure. Stop the gas in the section of pipe being repaired and blow down to atmosphere and purge that section of pipe. (Refer to Purging Procedure.)
3. Cut the section of pipe out and replace it with a section of coated steel or plastic pipe of the same nominal size. Unless otherwise approved by an Operations manager or supervisor, pipe to pipe connections shall be made by butt welding.
4. Weld-strap the coupling, properly coat the exposed steel surfaces, install cathodic protection devices, pressure test the pipe and reactivate the main when the work is completed. Take a pipe-soil resistance measurement prior to backfilling.
5. Apply the appropriate cathodic protection as directed by the Corrosion Technician.
6. If PE pipe is used for repair, CP test wires must be installed from either side of the repaired section and brought up into a test Box.

<p>VGS Operating Procedures</p>	<p>Repairs – Steel Pipe Effective Date: April 1, 2013 Page 3 of 3</p>
--	--

Repair of Existing Pipe - Medium Pressure

If corrosion is not excessive or the pipe is not damaged beyond repair, the pipe may be repaired by installing the appropriate repair clamp or weld fitting according to manufacturer's directions.

DRAFT - NOT FOR CONSTRUCTION

VGS Operating Procedures	Route Planning, Layout & Marking Effective Date: April 13, 2012 Page 1 of 2
---	--

Referring sections:

192.303 – Compliance with specifications or standards

192.361 – Service lines: Installation

Field Site Visit

A site visit by the Engineering and/or Construction Department to decide the routing and verify length of the proposed pipeline may be performed. This visit should also confirm underground structure locations and evaluate excavating conditions. Prints from other utilities for their underground plant should be obtained, where necessary, to assist with layout design.

Route Layout

Transmission Line or Main

The pipeline should be installed in as straight a line as possible, keeping offsets to a minimum.

Services

Services shall be installed in as straight a run as practical to the approved meter locations.

Future Main Extensions

Lateral starters for future extensions should not be specified unless main extensions are anticipated from those locations in the foreseeable future.

Multiple service lines and/or risers to one structure

The installation of more than one service per structure may only be done upon approval of the VP of Operations. If a multiple service is deemed necessary, it will be included in the Multiple-Services list which can be found at s: /CADD/ Drawings/Service Cards/Multiple Services that is maintained by the Construction Manager.

This list will record:

1. All single dwellings with more than one service riser.
2. All apartment houses with more than one service riser which are not located in

- close proximity to each other.
3. All non-residential addresses with more than one service riser which are not located in close proximity to each other.
 4. All schools, hospitals and churches with more than one service riser.
 5. Not all condominium complexes with multi-services will be added to this list. Only condo units with more than one service riser which are not located in close proximity to each other or the riser location is inconsistent with adjacent units will be added to this list.
 6. Not all shopping centers with multi-services will be added to this list. Only plazas with more than one service riser which are not located in close proximity to each other or the riser location is inconsistent with adjacent units will be added to this list.

All the address and services from this list will be used to update VGS records (Service cards, asbuilts and computer system) for emergency response coordination.

DRAFT - NOT FOR CONSTRUCTION

DRAFT - NOT FOR CONSTRUCTION

Referring sections:

192.303 – Compliance with specifications or standards

192.307 – Inspection of Materials

192.319 – Installation of pipe in a ditch

192.361 – Service lines: Installation

192.461 – External corrosion control: Protective coating

Protection from damage caused by storage, handling, transportation and trench conditions:

A. Storage: Storage of mill coated pipe must be in such a manner as to minimize coating damage. Pipe should be stockpiled with the bottom tier resting on padded skids, sand berms, or equivalent placed at right angles to the pipe. Maximum skid spacing should be 15'. All pipes shall be safely secured against movement using blocks.

B. Handling: Precautions must be taken to minimize coating damage during handling operations. This will include the use of leather or padded slings for lifting and moving pipe by machine. Dragging, rolling or dropping pipe is prohibited. Steel cable or chain chokers may not be used to lift pipe. Pipe callipers may be used only when they fit properly and are padded with appropriate materials. End hooks may also be used provided they are the proper size and pipes ends are protected.

C. Transporting: In transporting pipe by truck or trailer, padded supports and load binders must be used. Pipe must be adequately secured against movement.

D. Trench Preparation: Backfill must be of such a nature to prevent mechanical damage to the pipe or pipe coating. In areas of possible coating damage by rock or concrete supports, the pipe or structure should be protected.

E. Sand Padding: The bottom of all trenches shall either be stone-free or padded with stone-free backfill material prior to installing pipe in the trench. Each pipe shall be supported on well compacted stone-free backfill material to minimize pipe strain and external loading. The first layer of backfill around and on top of the pipe shall be stone-free backfill. All backfill shall be compacted to avoid settling. Prevention of damage to the coating of a pipe being installed by boring, driving or similar installation methods must be taken into consideration. Where significant damage to the coating may result from this type of installation method, the coated pipe shall be installed in an oversize bore or in a casing of sufficient diameter to allow for protection of the coating and provide electrical isolation between the carrier pipe and the casing. See Casing Procedure for more details.

DRAFT - NOT FOR CONSTRUCTION

VGS Operating Procedures	Test Requirements Effective Date: April 1, 2013 Page 1 of 4
---	--

Referring sections:

192.303 – Compliance with Specifications or Standards

192.503 – Test requirements: General requirements

192.509 – Test requirements for pipelines to operate below 100 p.s.i. gage

192.511 – Test requirements for service lines

192.513 – Test requirements for Plastic Pipelines

192.517 – Records

192.719 – Transmission lines: Testing of repairs

192.725 – Test requirements for reinstating service lines

Pressure Testing Services and Service Mains

All new SERVICE LINES and all fully renewed service lines shall be tested from the main connection to the riser valve.

A SERVICE MAIN is defined as a distribution line on one property or common land that has a maximum of two services teeing off, each with their own riser. A service main shall be limited to a size of 1-3/4 inches or smaller and less than 400' feet in length.

Partial service that is being re-used shall be tested as follows:

When the portion from the curb to the meter of the service is being reused the service shall be tested from the point of disconnection to the riser valve. When a high or medium pressure service is being re-used from the main to the curb, the full service shall be tested in the same manner as a new service.

The service tee shall be included in the test, wherever practical, if the portion of the service from the main to the curb, or the entire service line, is to be tested. Alternately, the service tee shall be given a soap leak test at the operating pressure of the main when placed in service.

Testing New Service together with New Main

When a new service is to be tested together with a new main, the service tee shall be tapped or drilled. The curb valve shall be left in the open position, and the riser valve shall be in the closed position and plugged.

The main and service lines shall be subjected to a pressure test equal to the pressure and duration required for the main. During the test, all exposed joints should be tested with a

VGS Operating Procedures	Test Requirements Effective Date: April 1, 2013 Page 2 of 4
---	--

soap solution for leakage.

Testing New Services Only - Operating 100 PSIG or Less

A NEW SERVICE line shall be tested from the meter valve to the main. A new service line to be operated at 100 PSIG or less shall be subjected to a pressure test using a minimum test pressure of 150 PSIG and for a minimum duration of ten minutes to detect hazardous leakage. The curb valve shall be in the open position and the test fitting/gauge will be above the open riser valve. During the test, all exposed joints should be tested with a soap solution for leakage.

Testing Service Line Replacements

Full service line replacements shall be tested with air or other inert gas at the same pressure and for the same duration as a new service line. All tests, other than those performed at line pressure, shall be performed at the same pressure and duration as a new service. The new service tee shall be soap-tested at operating pressure.

Testing Reconnected Service Lines

Every effort should be made to replace a previously disconnected service rather than reconnect it. However, if this is not practical, a disconnected service line shall be tested in the same manner as a new service line before being reinstated.

A service temporarily disconnected from the main shall be tested from the point of disconnection to the riser valve in the same manner as a new service line before reconnection. If a provision is made to maintain continuous service, such as installation of a bypass, any part of the original service line used to maintain continuous service need not be tested.

Testing Service Mains

A new service main shall be subjected to a pressure test using a minimum test pressure of 150 PSIG. The pressure must be maintained at or above the test pressure of 150 PSIG for a minimum of one hour to detect any hazardous leakage. The curb valve shall be in the open position and the test fitting/gauge will be above the open riser valve. During the test, all exposed joints should be tested with a soap solution for leakage.

Every effort shall be made to replace a previously disconnected service rather than reconnect it. However, if this is not practical, a disconnected service line shall be tested in the same manner as a new service line before being reinstated.

A service temporarily disconnected from the main shall be tested from the point of

VGS Operating Procedures	Test Requirements Effective Date: April 1, 2013 Page 3 of 4
---	--

disconnection to the riser valve in the same manner as a new service line.

TEST PROCEDURES:

- 1) The pressure test shall be performed using air, natural gas or an inert gas such as nitrogen as a test medium. The service line shall be backfilled, with the exception of any tees, joints or connections that should be soap tested.
- 2) A reconnected medium pressure service shall be subjected to a pressure test using a minimum test pressure of 150 PSIG and a minimum duration of ten minutes. The meter valve shall be in the closed position with the outlet plugged. During the test, all exposed joints shall be tested with a soap solution for leakage.

Pressure Testing Procedures:

Test Conditions

All VGS gas distribution mains operating below 100 psig shall maintain the test pressure for a minimum of 8 hours. All other mains shall be tested in accordance with Part J - 192.505, 192.507 or 192.513 as applicable.

No mechanical end caps will be utilized on steel mains during pressure testing unless properly secured. (Refer to Repairs – Steel Pipe Procedure.)

All pressure tests on steel mains will be done by welding a steel end cap and pipe pup to the main with a pressure testing and recording chart connections. Mechanical fitting end caps shall not be used for any pressure test on steel main or services.

Pressure Chart Recorders

VGS and contractor chart recorders will be calibrated annually prior to the start of construction season using the manufacturer's calibration procedures. Calibration will also be conducted if it is apparent that the recorder has been exposed to situations that may have damaged it (fall from truck, etc). In addition to using a pressure recording chart when testing mains, a physical pressure gauge will be used while the test is put on the main.

Procedure in Event of Pressure Test Failure

The main shall withstand the test pressure specified without showing any evidence of leakage or other defects. If leakage or other defects appear, the affected portion will be

VGS Operating Procedures	Test Requirements Effective Date: April 1, 2013 Page 4 of 4
---	--

replaced or repaired in a manner which meets or exceeds the minimum design requirements of the main. The main will then be retested.

Main Records

A calibrated chart recorder should be used to record the pressure over the test period, and the chart should be kept in the fire safe filing cabinet as a permanent record along with the pressure test record form.

Note: VGS and contractor chart recorders will be calibrated annually prior to the start of construction season using the manufacturer's calibration procedures. Calibration will also be conducted if it is apparent that the recorder has been exposed to situations that may have damaged it (fall from truck, etc).

Service Main Records

All pressure test results should be recorded on the service card(s).

Service Line Records

Service test results should be recorded on the service card.

DRAFT - NOT FOR CONSTRUCTION

VGS Operating Procedures	Tie-Ins Effective Date: April 1, 2013 Page 1 of 6
---	--

Referring section:

192.303 – Compliance with specifications or standards

192.367 – Service Lines: General Requirements for Connections to Main Piping

Tie-In Methods - Main Extensions

General Requirements

All tie-ins shall be accomplished by approved methods of tapping, stopping and bypassing, using appropriate procedures and equipment for the main size and pressure range involved. Refer to VGS Tapping and/or Stop-offs and Bypassing Procedure for details. When fittings are used for tie-ins, their installation and use shall follow the manufacturer's recommendations. Welded steel joints or butt-fused plastic joints shall be made by qualified personnel in accordance with the applicable regulations and procedures.

Refer to VGS Purging Procedure.

Safety Precautions

All tie-ins shall proceed with due regard for the safety of all employees and the public. Specific areas of concern to the supervisor in charge should include:

- a. traffic control
- b. venting and purging of gas
- c. proper operation of equipment
- d. condition of equipment
- e. shoring requirements
- f. bonding for arc prevention
- g. fire extinguishers
- h. personal safety equipment

Types of Tie-Ins

Tie-ins are generally classified into three types:

- a. end-to-end
- b. cut-in lateral
- c. tapped lateral

The general descriptions of the classifications follow.

VGS Operating Procedures	Tie-Ins Effective Date: April 1, 2013 Page 2 of 6
---	--

End-to-End Tie-ins

In this class the new pipeline is connected directly to the end of the existing pipeline. The existing pipeline is stopped off, the end opened, and the connection to the new pipeline is made. Generally a bypass is only required where the stopping equipment needs back-pressuring to release the plugging head. See Figures 3503.1B through 3503.1D for typical end-to-end details.

Cut-in Lateral Tie-ins

In this class the existing pipeline is stopped off at both ends of the portion of pipeline where the tie-in will occur. A bypass may be required to prevent outages. A portion of the pipeline is removed from between the stoppers and is replaced with a fabricated tee assembly attached to the new pipeline extension. The stoppers are removed, and gas is introduced into the new pipeline. See Figures 3503.2B and 3503.2C for typical cut-in lateral tie-in details.

Tapped Lateral Tie-ins

In this class the existing pipeline will have an assembly attached to it which connects to the new pipeline. The existing pipeline is tapped, under pressure, through the assembly to create an outlet which shall feed the new lateral pipeline. Some tapped laterals require removal of a portion of the assembly to facilitate the tapping operation, then reassembly and gassing of the new lateral pipeline. Bypass connections are generally not required for tapped lateral tie-ins. See Figures 3503.3A, 3503.3B and 3503.3D for typical tapped lateral tie-in details.

Tie-ins to Steel Mains

General

All coating, in the area where fitting must be attached to existing steel mains, shall be carefully removed and the surface cleaned. Whenever possible all plastic by plastic joints should be heat fused. Joints between 2 inch plastic pipeline and steel fitting should be protected with protection sleeves or support cradles. Permanent blocking shall not be used beneath plastic piping or any plastic by steel joint used at tie-in points. Temporary blocking may be used during the tie-in procedure. All steel pipe and fittings must be thoroughly coated and wrapped. Locator wires must be installed along with all plastic gas pipelines. At the tie-in or transition point the locator wire shall be terminated in a locator box. . At the tie-in or transition point when steel pipe meets plastic pipe a black wire shall be cad- welded to the steel pipe and brought into a locator box with the locator wire from the plastic pipe segment.

VGS Operating Procedures	Tie-Ins Effective Date: April 1, 2013 Page 3 of 6
---	--

No Blow Tee Branch Connections

A. General

These tie-ins are to be made with no-blow type tee line stopper fittings and are utilized when installing 2" through 6" plastic mains from existing larger sized steel mains.

B. Installation Procedure

1. Strip coating from the existing main and weld on a no-blow tee.
2. The following method must be used to connect the plastic piping:
Weld a transition fitting to the tee. The plastic piping installed per step 3 may be connected by heat fusion or other suitable methods.
3. Install the balance of the plastic pipe and place the locator wire.
4. Leak test the entire installation, including the no-blow tee.
5. Remove the leak test and drill out the main following manufacturer's instructions. Be sure to refer to the VGS Purging Procedures.
6. Coat and wrap all exposed metal of the tie-in connection and the existing mains.
7. The locator wire should be terminated in a locator box directly over tie-in. Also see notes in previous "Tie-ins to Steel Mains - General" section.

Line/Bottom out Stopper Fittings

- A. This type tie-in is used when a branch extension of the same size as the existing steel main is required.

B. Installation Procedure

1. Strip all coating from the steel main in the areas where the fitting will be positioned and weld it in place.
2. The following method must be used to connect to the plastic piping:
Weld a transition fitting to the elbow. The plastic piping installed per step 4 may be heat fused or electrofused to the transition fitting or connected by other suitable methods.
3. Install the balance of the plastic pipe and place the locator wire.

DRAFT - NOT FOR CONSTRUCTION

VGS Operating Procedures	Tie-Ins Effective Date: April 1, 2013 Page 4 of 6
---	--

4. Leak test the entire installation, including the fitting.
5. Remove the leak test and drill out main following manufacturer's instructions.
6. Coat and wrap all exposed metal of the tie-in connections and the existing main. Any plastic to steel joint must be coated.
7. The locator wire should be terminated in a locator box. Also see notes in previous "Tie-ins to Steel Mains - General" section.

Tie-ins to Plastic Mains, Procedures

Stop-off equipment or valve shall be used for all tie-ins to existing plastic mains. Squeeze-off procedures shall be followed. All plastic piping that is to be tied-in per instruction within this section must have successfully passed the pressure/leak tests. Static electricity - Safe working practices shall be followed prior to performing a tie-in to existing plastic piping. The pipe, on either side of the cut, shall be grounded using wet rags and a soapy solution.

Plastic by plastic joints shall be heat fused with the proper equipment. Permanent blocking shall not be used beneath plastic piping or joints. Temporary blocking may be used during the tie-in procedure. Locator wires will be installed with all new directly buried plastic piping. All the wires will be of sufficient length to pull out of box 12 inches for easy access. Slack should be provided in the plastic piping to compensate for thermal expansion and contraction.

Refer to VGS Purging Procedure.

Two Inch Extension: Procedures

General

This type tie-in is utilized when extending an existing 2-inch steel main with 2" plastic pipe.

Preparation

The plastic piping can be installed with an offset prior to being tied in, however it is not required. The Plastic piping should overlap the existing steel main, while providing enough slack to compensate for thermal contraction.

Tie-in Procedure

1. Strip coating from steel main approximately 24 inches from the end plate and weld on a line stopper fitting.
2. Drill out pipe using appropriate machine per instruction.
3. Cut off end plate.

VGS Operating Procedures	Tie-Ins Effective Date: April 1, 2013 Page 5 of 6
---	--

4. Cut the end cap off the plastic pipe, weld to a transition fitting or use an appropriate pull-out resistant coupling.
5. Clear the main per Vermont Gas Systems Purging Procedures in Section L.
6. Thoroughly wrap all exposed metal.
7. Terminate the tracer wire in a locator box located over the tie-in. Also see notes in previous "Tie-ins to Steel Mains - General" section.

Testing Tie-in Connections

Tie-in connections shall be tested with soap solution at operating pressure.

Service Connections to Mains

General Requirements

All services shall make their main connection at the top of the main whenever practical. Alternately, a side connection is allowable where required.

Only new fittings, new coated steel or P.E. pipe will be installed for underground use. Where practical, welded, fused joints or compression type fittings will be used in all underground services. All fittings will be carefully inspected for defects in the metal or threads before installation. Any pipe or fittings with a suspected defect will be returned to the warehouse. Long sweep bends will be used whenever practical. Approved pipe dope will be used on all threaded connections.

Connections to Steel Mains

Medium Pressure

Medium-pressure connections should be made by welding approved tees to the main. Where service tees have a built-in tapping device, said device shall be used to tap those tees. Other tees shall be tapped using equipment designed for tapping the main without an uncontrollable escape of gas.

Taps for Services on Steel Mains

Taps will be made using welded fittings and equipment designed for tapping the main without an uncontrolled escape of gas. These fittings and equipment will be designed to

VGS Operating Procedures	Tie-Ins Effective Date: April 1, 2013 Page 6 of 6
---	--

withstand the maximum operating pressure in the main.

The tee will be welded to the main. Welding reinforcement on the main is not required unless:

1. The pressure in the main will exceed 100 psig.
2. Excessive external loads are expected on the service.

If welding reinforcement on the main is required, a full encirclement reinforcement ring or a pressure control fitting will be used. The fittings at the main will be designed to relieve stresses caused by settlement of the service.

The recommended tap size for services is at least 3/8 inch. This will allow a stopper, or pin, to be installed to shut off the gas. Do not make a hole in an unpressurized main and then set the service tee or weld-o-let on the main to be welded in place.

Connections to Plastic Mains

Service connections to plastic mains shall be made by sidewall fusion or electrofusion of approved fittings. Those service connections which have built-in taps shall utilize them to tap the main; other fittings shall use approved methods and equipment for tapping the main.

DRAFT - NOT FOR CONSTRUCTION

VGS Operating Procedures	Underground Clearance Effective Date: April 13, 2012 Page 1 of 1
---	---

Referring sections:

192.303 – Compliance with Specifications or Standards

192.325 – Underground Clearance

192.361 – Service lines: Installation

When able and practical to do so, VGS will maintain a separation of at least three feet from other underground structures. Transmission and distribution lines will be installed with at least 12 inches of clearance from other underground structures (utility poles, utility pedestals, vaults, etc.) not associated with the pipelines. Whenever clearances on transmission lines or distribution mains are less than one foot, closer placement will be allowed if the line is provided with additional appropriate protection and provided the selected protective measures are approved by the Operations Department. Additionally, when 12 inches of clearance cannot be met, a line marker, appropriate for the specific location, will be installed if practicable to do so, to alert others of the proximity of adjacent buried natural gas line.

When installing services, attempt to maintain 12 inches of clearance between other structures. Do not install the service under or through any structure that could damage the pipe by excessive settlement, vibration, movement or corrosion. Do not install the service under any building or proposed building site.

All pipelines will be installed in such a manner that they are completely free of electrical contacts with other underground facilities. All plastic pipelines will be installed with sufficient clearance, or be insulated from any source of heat, so as to prevent the heat from impairing the serviceability of the pipe.

Padding Materials

Where external protection against contacts is necessary, pads or shields may be installed as required. The following materials are approved for such use:

- a. Rock-shield
- b. Neoprene rubber pads
- c. Service protective sleeves
- d. Fiberglass insulating sheets
- e. Cradles cut from polyethylene piping

Installation of these materials will be made whenever the pipeline crosses in close proximity to another structure and a contact could occur through settlement or movement in the trench area. Other protective materials and methods, other than those listed above, may be acceptable provided they are approved by the Engineering Department.

DRAFT - NOT FOR CONSTRUCTION

VGS Operating Procedures	Valves Effective Date: April 1, 2013 Page 1 of 8
---	---

Referring sections:

192.179 – Transmission line valves

192.181 – Distribution line valves

192.193 – Valve installation in plastic pipe

192.303 – Compliance with specifications or standards

192.361 – Service lines: Installation

192.363 – Service lines: Valve requirements

192.365 – Service lines: Location of valves

192.745 – Valve maintenance: Transmission lines

192.747 – Valve maintenance: Distribution systems

Vermont Rule 6.156 – Curb shut-offs

Sectionalizing and branch control valves shall be installed, as required, to control gas flow for routine maintenance or emergency operations. Locations of sectional valves on transmission lines shall be determined by the Engineering Department. Branch control valves shall be located as close as practical to the branch connection.

Regulator Station Valves

A shut off valve shall be installed on the inlet and outlet mains of each regulator station.

Valves shall be located in a manner that will provide ready access for operations. Valves shall not be located in areas such as the portions of gutters or driveways where vehicles would make the valves inaccessible or where surface water would be troublesome. The inlet, outlet and other shut off valves shall be a plug or ball type unless otherwise specified.

Valves In Plastic Piping

Line control valves for PE plastic mains are used to control the flow of gas in a segment of the distribution system. This may be required for emergency repairs or to facilitate tie-ins.

All line valves in plastic piping must be installed below grade and be equipped with roadway boxes that provide access to the operating mechanism. Valves should be installed in piping systems whenever indicated on construction drawings or sketches.

- a. Plastic Valves - All valves that are installed in PE plastic piping shall be the plastic butt fused, or electrofused type.

VGS Operating Procedures	Valves Effective Date: April 1, 2013 Page 2 of 8
---	---

- b. Operating extensions - Plastic heat fused valves will be provided with a high head extension that may be used to operate the valve from grade. The fabrication should be welded together. These 1-1/2" IPS pipe extensions must be cut to fit the depth conditions of the installation, terminating approximately 6 inches below grade. Use of prefabricated PE high heads is allowable up to 4" pipe.
- c. Valve housings - An adjustable plastic roadway box must be placed over the high head extension. These will snap over the valve body to create a tight seal.
- d. Valve Identification and Records - Ties should be taken from designed valve systems. Measurements from at least two above ground structures should be obtained for the as-builts. This information will assist in locating for installation, operational or maintenance purposes in the future.

Valves

All valves shall be installed in accordance with the manufacturers' recommendations to insure proper operation of the valve after installation. As much as practical, valves shall be installed so that they will not be located in areas of dense traffic, thus allowing sufficient access in an emergency. All valves with grease fittings shall be greased after welding is completed and valve body has cooled. Only appropriate grease for the valve shall be used. Valves of sizes larger than 12" shall have a poured concrete pad of sufficient size for support. The valve shall have free movement on the pad for line expansion.

Curb Valves

Curb valves shall be installed during any renewals where the meter is left inside, or any partial renewals as required by Subpart H and subject to the requirements of applicable sections of Subpart H.

Curb Valve Types

Curb valves for use with plastic piping shall be attached to the service piping by butt/electro-fusion. Butt/electro-fusion curb valves must be compatible to the piping in use for proper fusion.

Curb valves for use with steel piping shall generally be either welded or compression.

VGS Operating Procedures	Valves Effective Date: April 1, 2013 Page 3 of 8
---	---

Use of Curb Valves

A curb valve will be installed in all commercial services and residential services with a load greater than 2000 scfh.

Curb valves will be installed on any service that has the gas regulator located inside the building or structure.

Location of Curb Valves

The curb valve will be installed within 2 feet of the main whenever possible. The curb valve box will be centered perpendicularly over the curb valve so the curb key can be inserted easily to operate the curb valve.

RiserValves - Service Riser or Entrance

An approved riser valve shall be installed on the service riser for an outside service, or as close as practical to the point of entry on an inside service. Such riser valve shall be in an accessible location and shall have, or accept, an approved locking device.

Meter Valves

Individual meter valves shall be installed on each meter on a multi-meter manifold.

Transmission valves

VGS's transmission valves will be operated to the extent necessary to establish operability during an emergency. When operating a valve, caution should be used to avoid a service outage or over pressurization of the system.

In cases where valves are difficult to turn or are leaking, they will be lubricated and re-packed, per manufacturer's recommendations, according to the type of valve involved. When maintenance and inspections have been completed, steps shall be taken to verify that the valves are in the proper position. Inspection shall include checking of alignment to permit use, if required, of a key or wrench and clearing any debris from the valve boxes.

The VGS Maintenance department will ensure a current list of mainline transmission valves, as well as other valves VGS deems critical, is maintained. The valves shall be

VGS Operating Procedures	Valves Effective Date: April 1, 2013 Page 4 of 8
---	---

inspected and partially operated at intervals not exceeding 15 months, but at least once each year. A valve maintenance record shall be kept to record the maintenance of each valve.

Any critical mainline valve not operable will be reported to the Supervisor of Maintenance or Operations Manager and repairs will be made as soon as possible.

Transmission line valves requiring maintenance in this section include buried main line, loop line, lateral line, station inlet, bridal tap, and bypass valves. A list of these valves is placed in the transmission line valve book in the Measurement & Control Office.

Remote Operated Transmission line valves

Remote operated transmission line valves are capable of being closed by a Gas Control Operator via the Scada control system in emergency situations. The valves can be closed manually or by remote operations and can only be opened manually. The remote operated valves are located listed sites.

- MLV- 20 Carter Hill Rd 10" Main Line valve
- MLV-25 Route 78 16" Main Line Valve
- MLV- 30 Swanton Gate 10" Main Line Valve
- MLV- 40 Beebe Rd 10" Main Line Valve
- MLV- 45 Beebe Rd 16" Main Line Valve
- MLV- 50 Lake Rd 10" Main Line Valve
- SIV-21 Nason St. 8" Station Inlet Valve

Key valves

Refer to Key Valve Procedure

Valve Maintenance Procedures

WKM Gate Valves:

WKM Gate Valves are equipped with the following fittings for lubricating and packing:

- 1) Grease/Sealant Fittings: ½" and 1" NPT safety ball check grease fittings with safety caps. These fittings are used in conjunction with a pressure releasing tool and/or grease gun to drain or lubricate the valves.
- 2) Alemite Stem Bearing Lube Fitting: Standard Alemite grease fitting for injecting grease into the stem bearing housing.
- 3) Packing Fittings: Ball check fittings (½"NPT) make it possible to add stick packing directly through the fitting, when valve is under pressure.

Venting a Valve Body and Yoke Tube:

- 1) Place the valve in either the fully open or fully closed position.
- 2) Remove the body grease fitting safety cap nearest the top of the valve body.
NOTE: If the ball check is not holding pressure, body pressure will blow through the two bleed holes in the cap. If the pressure is too great, do not proceed. Call for assistance from WKM Products representative.
- 3) Screw a pressure releasing tool with its stinger fully retracted onto the fitting.
- 4) Screw in the stinger and allow the valve body pressure to blow down.
- 5) After venting, retract the pressure releasing tool stinger and remove the tool.
- 6) Replace the body grease fitting safety cap and return the valve to its normal operating position. NOTE: If the body pressure does not fall to zero when the valve is in the open position, the valve must be placed in the closed position to vent. If the valve still won't vent, and is leaking, call a WKM Products Representative.

Draining The Valve Body:

To drain a valve, follow the same steps and precautions as for venting except that the pressure fitting release tool is installed on the bottom fitting.

- 1) Place the valve in either the fully open or fully closed position.
- 2) Remove the body grease fitting safety cap nearest the bottom of the valve body.
NOTE: If the ball check is not holding pressure, body pressure will blow through the two bleed holes in the cap. If the pressure is too great, do not proceed. Call for assistance from WKM Products representative.
- 3) Screw a pressure releasing tool with its stinger fully retracted onto the fitting.
- 4) Screw in the stinger and allow the valve body pressure to blow down.
- 5) After venting, retract the pressure releasing tool stinger and remove the tool.
- 6) Replace the body grease fitting safety cap and return the valve to its normal operating position. NOTE: If the body pressure does not fall to zero when the valve is in the open position, the valve must be placed in the closed position to vent. If the valve still won't vent, and is leaking, call a WKM Products Representative.

Lubricating Instructions:

These instructions are for lubrication as a part of routine maintenance. For other lubrication requirements, see the manufacturer's instructions.

Stem Lubrication:

The stem is coated with W-K-M HF-7 (molybdenum sulfide), a dry lubricant. If

VGS Operating Procedures	Valves Effective Date: April 1, 2013 Page 6 of 8
---	---

additional stem lubricant is required, remove the stem protector and apply the grease directly to the stem threads.

Draining the Yoke Tube:

Check the yoke tube periodically for condensation. Be sure the drain hole is not plugged and that the plastic drain plug has been removed.

Stem Bearing Lubrication:

The Stem Bearing is lubricated through a 1/8" NPT Alemite type grease fitting located near the top of the valve. Only a small amount of good lithium base grease is needed. NOTE: Over-lubrication of the stem bearing will force excess grease into the yoke tube.

The following routine maintenance schedule is recommended by the manufacturer.

- 1) Operate the valve once a month if possible. Turn the valve wheel three complete turns. Return the wheel to original full open position.
- 2) Winterize the valve at the onset of cold weather.
 - a) Drain the valve and yoke tube to eliminate water accumulation.
 - b) If the valve body cannot be drained to eliminate water accumulation, alcohol or another appropriate antifreeze solution should be injected into the valve body. See manufacturer's instructions for body capacities and antifreeze solutions.
 - c) Cold weather may cause the lubricants normally used for the stem, stem bearings and operator to be stiff. This may make the valve hard to operate. Replacing these lubricants with cold weather grade lubricant will return the valve to smooth, easy operation.
 - d) Stem and handwheel extensions should be drained of any water that may have become trapped in the extension housing. If the extension housing cannot be drained, alcohol or antifreeze should be injected.
- 3) Once each year, drain the body of accumulated materials.
- 4) Once each year, grease handwheel or actuator bearings.
- 5) Once each year, more often if necessary, check for leaks by bleeding body pressure while valve is in closed position.

Cameron Ball Valves

The Cameron Ball Valve is non-lubricated. Since all bearings and seals contained in the

VGS Operating Procedures	Valves Effective Date: April 1, 2013 Page 7 of 8
---	---

ball valve are self-lubricating, no lubrication maintenance is needed.

Routine Maintenance Schedule -

Operate the valve at least once each year by turning the wheel three complete turns.
Return the valve to its original full open position.

Grove Ball Valves

The Grove Ball Valve is non-lubricated. Since all bearings and seals contained in the ball valve are self-lubricating, no lubrication maintenance is needed.

Routine Maintenance Schedule -

Operate the valve at least once each year by turning the wheel three complete turns.
Return the valve to its original full open position.

Valve Maintenance Procedures

Valve boxes will be located using the ties from the designated valve book. Check valve box for debris and remove material by blowing out or vacuuming if needed. Also check to make sure the valve box is aligned over the valve for easy access of the valve wrench onto the valve high head.

Lubricated Valves

Lubricated valves will be greased prior turning. Clean off the grease head coupler and attach the high pressure grease gun fitting, lifting up gently on the back end of the coupler, until the fitting head stops.

Inject sealant by hand pumping the grease gun as long as the needle on the pressure gauge climbs steadily. Keep pumping until the pressure gauge reading no longer rises but begins to drop and the pumping effort decreases. At this point, the valve has been sufficiently filled and the sealant injection should be stopped immediately.

The plug valve can then be turned with a valve wrench to check ease of operation. Operation of the valve should not be done to the fully closed position to prevent loss of pressure on single feed systems.

<p style="text-align: center;">VGS Operating Procedures</p>	<p>Valves Effective Date: April 1, 2013 Page 8 of 8</p>
--	--

PE & Steel Ball Valves

The valve can then be turned with a valve wrench to check ease of operation. Operation of the valve should not be done to the fully closed position to prevent loss of pressure on single feed systems.

Valve box covers will then be placed back on the box and painted yellow.

DRAFT - NOT FOR CONSTRUCTION

VGS Operating Procedures	Welding Effective Date: December 1, 2010 Page 1 of 8
---	---

Referring sections:

192.225 – Welding procedures

192.227 – Qualification of welders

192.229 – Limitations on welders

192.231 – Protection from weather

192.233 – Miter joints

192.235 – Preparation for welding

192.241 – Inspection and test of welds

192.243 – Nondestructive testing

192.245 – Repair or removal of defects

192.303 – Compliance with Specifications or Standards

192.309 – Repair of Steel Pipe

192.715 – Transmission lines: Permanent repair of welds

192.719 – Transmission lines: Testing of Repairs

See also following procedure:

Prevention of Accidental Ignition

Welding Procedure Specifications will be established and qualified by VGS, or its contractors and in accordance with the applicable code or standard to demonstrate that welds have suitable mechanical properties such as strength, ductility and hardness.

The details of qualified Welding Procedure Specifications, including test results, as set forth in API Standard 1104 (20th Edition) shall be recorded in detail on forms designated by VGS. Nonessential variable changes in the qualified Welding Procedure Specification, as determined by VGS shall be fully documented and recorded as a "revised" qualified Welding Procedure Specification.

Welding & Cutting - General Safe Working Practices

The Prevention of Accidental Ignition Procedure shall be followed. At all times that welding or cutting involving live gas facilities is occurring at a work site, a VGS employee in addition to the welder must be on site (outside of any excavation) to respond to any unusual circumstances.

- a. Arc or flame welding and cutting equipment shall be used only by properly trained personnel.

- b. Fire, explosion, toxic fumes and possible electric shock are primary hazards which should be guarded against when welding, burning or brazing.
- c. A fire extinguisher shall be ready for immediate use when welding or cutting near flammable materials. In addition, a fire watch will be posted during the welding or cutting operations when combustible materials are in the area. The fire watch will be maintained for a reasonable period of time after welding or cutting operations have ceased to ensure flammable materials do not ignite from source such as smoldering slag, etc.
- d. Welding and cutting assignments, whether using arc or flame, shall be shielded or barricaded to protect others in the area from spatter and from harmful rays and to prevent ignition of flammable material if they cannot be moved.
- e. Proper protective equipment shall be worn during welding and cutting work. Protective equipment for arc or flame welding includes hard hat, approved goggles or safety glasses and hood, long cuffed gloves and fire retardant or leather clothing - the specific protection depends upon the specific job hazards. Clothing shall be free of excessive oil or grease. Other garments should be fastened at neck and ankles.
- f. Blowers should be utilized when welding indoors or in a confined space such as a trench when air quality is significantly impacted.
- g. Welding or cutting of any pipeline, tank or empty container shall not be performed until it is certain the area is free from an explosive mixture of gases.
- h. Hot material should not be left unguarded unless it is plainly marked as being "hot".
- i. When necessary for cables or hoses to cross walkways for extended periods of time, they should be suspended or bridged with planking so as to protect them from traffic.
- j. In the case of gas welding equipment, grease or oil should never come in contact with regulators, valves, cylinders or hose connections.
- k. An approved igniter should be used to light the torch. Do not relight from hot work.
- l. When igniting a torch, it should be held away from the body.
- m. In the case of a torch flashback, valves at cylinders shall be closed quickly; then check hose, regulators and torch for damage. Check tip for plugging before attempting to relight.
- n. An electric welding machine shall be properly grounded, in accordance with the manufactures instructions, before using.
- o. Compressed gases shall be used only by experienced and properly instructed persons.
- p. When welding or cutting in elevated positions, precaution shall be taken to prevent sparks or hot metal from falling onto people or flammable material below. A non-flammable tarp or its equivalent shall be used.
- q. Fire extinguishing equipment shall be immediately available at all locations where welding and cutting equipment is used.

VGS Operating Procedures	Welding Effective Date: December 1, 2010 Page 3 of 8
---	---

- r. Proper eye protection shall be worn to guard against flying particles of scale when the helmet is raised.
- s. All arc welding shall be shielded behind flame-proof screens or all persons in the vicinity shall wear approved tinted eye protection. A welder, unless working behind a screen shall not strike an arc with an electrode until nearby persons who may be exposed to the arc have been given ample warning.
- t. When gauges are removed and caps replaced, the oxygen and acetylene bottles shall be separated into storage areas no less than 20 feet apart
- u. Compressed gas cylinders shall always be stored in the upright position and secured against falling. They shall also be adequately secured while being transported in a motor vehicle.

General

Prior to welding or cutting in or around a structure or area containing gas facilities, a thorough check should be made with a CGI for the presence of a combustible gas mixture. When working in a confined area or trench, appropriate instruments should be used to ensure there is not an oxygen deficient or combustible atmosphere when such atmospheres are reasonably likely to be present.

Pipelines Filled with Gas

Refer to API 1104 Inservice Welding.

Pipelines Containing Air

- a) Before the work is started, and at intervals as the work progresses, the atmosphere in the vicinity of the zone to be heated should be tested with a CGI. Unless a suitable means (such as an air blower) is used to prevent a combustible mixture in the work area, welding, cutting or other operations that could be a source of ignition should not be performed on a pipeline, main or other apparatus that contains air and is connected to a source of gas.
- b) When the means noted in above (a) are not used, one or more of the following precautions are suggested, depending on the circumstances at the job.
 - 1) The pipe which is to be welded or cut should be purged with an inert gas (nitrogen).
 - 2) The pipe is continuously purged with air so a combustible mixture does not form.

VGS Operating Procedures	Welding Effective Date: December 1, 2010 Page 4 of 8
---	---

Welder Qualifications

Welder qualifications are the responsibility of the Supervisor of Maintenance, or qualified designee. He/she shall ensure that qualifications are conducted, and maintained, in accordance with applicable welding standards. He/she shall maintain records establishing welding qualification and testing.

Reference applicable sections of API 1104 (20th Edition) for welding qualification specifications

Limitation on Qualified Welders

No welder shall weld outside the scope of his qualification.

No welder may weld using a particular welding process or procedure without a re-qualification test if more than six (6) calendar months have elapsed since that welder last qualified. To re-qualify, a welder must make a butt-weld in the fixed position within the scope of the welder's qualification. The weld shall be examined according to Section 3 (Destructive Testing) or Section 6 (Non-Destructive Testing) of API 1104 or DOT 192.

Methods

Welds shall be made by the manual shielded metal-arc method or other methods approved by the Supervisor of Maintenance, or qualified designee which has been qualified and have written procedures. All requirements affecting the quality of the completed welds shall apply equally to roll welding and position welding.

Materials

Electrodes shall conform to American Welding Society AWS Rod Classifications. Flux-coated electrodes shall be kept dry, stored to prevent moisture loss or moisture absorption, and shall be handled in such a manner as to prevent any damage thereto. Electrodes in opened containers shall be protected from excessive moisture changes. Electrodes which show signs of deterioration or damage shall not be used in any welding procedure.

Production Welding

Each joint end of pipe shall be cleaned and free of debris before being aligned for welding.

Bevels shall be thoroughly cleaned prior to welding, and cleaning methods shall not in any way alter the bevel design specified in the Welding Procedure Specification. Field

VGS Operating Procedures	Welding Effective Date: December 1, 2010 Page 5 of 8
---	---

beveling and cleaning shall be made in accordance with the Welding Procedure Specification.

The alignment of abutting ends of longitudinal seam pipe, except in bend section, shall be so as to stagger the longitudinal seams and be within the top half of the pipe as laid.

Steel die stamping of welds for any reason will not be allowed. Hammering, jacking, gouging, arc burning, or other damage inflicting actions will not be allowed.

The alignment of abutting pipe ends shall be such as to minimize the offset between pipe surfaces. For pipe of the same nominal wall thickness, the offset shall not exceed one-sixteenth (1/16) of an inch. Back welding will not be allowed without the express authorization of the Supervisor of Maintenance, or qualified designee and in no event shall any back welding be done without preheating to the prescribed temperature.

When internal line-up clamps shall be used, they shall not be removed until the root bead is completed. When external line-up clamps are used, the clamp shall be held in place until at least 50% of the root bead circumference is welded in increments spaced equally around the pipe.

Partially completed welds that have undergone cooling shall be preheated prior to completion of the weld at the option of the Supervisor of Maintenance, or qualified designee. Preheating of pipe ends prior to welding may be required at any time at the discretion of the Supervisor of Maintenance, or qualified designee.

Arc burns are not permitted under any circumstances. Any damaged area of the pipe containing an arc burn shall be removed by cutting out a cylinder of the pipe containing the damaged metal on new installations. Other repairs on in-service pipe shall be approved by the Supervisor of Maintenance, or qualified designee.

Tack welding of grounding clamps and other devices to pipe shall not be permitted.

Roll welding, when permitted, shall be carried out in accordance with the qualified welding procedure.

Hot weld shall be protected at all times from sudden cooling, water quenching or movement.

Welding rod stubs or unused welding rod shall be carefully removed from the site and shall not be discarded in the ditch, right-of-way or elsewhere on the site.

VGS Operating Procedures	Welding Effective Date: December 1, 2010 Page 6 of 8
---	---

Miter Joints

A miter joint on steel pipe shall not deflect the pipe more than 3 degrees.

Weather Conditions

Welding shall not be done when the quality of the completed weld would be significantly impaired by the prevailing weather conditions, including, but not limited to, airborne moisture, blowing sands, or high winds. Wind/rain shields should be considered when conditions are harsh.

Visual Inspection of Welds

Welds on distribution pressure piping shall be visually inspected prior to coating or wrapping. Welds of unacceptable visual appearance shall be repaired as required or removed from the line.

Unless otherwise approved by an Operations Manager or Supervisor and within the limits of applicable codes and regulations, all welds on transmission pressure pipelines and piping shall be visually and non-destructively tested. Welds not meeting test requirements shall be repaired or removed and replaced within the allowances of applicable codes and regulations.

Nondestructive Testing of Welds

Nondestructive testing of welds shall be performed only by qualified operators or contractors.

Nondestructively tested welds shall be recorded and the records shall be retained for the life of the pipeline.

The weld location records shall show as-built stationing and/or geographic feature, the number of girth welds made, the number nondestructively tested and the number rejected, and the disposition of rejected welds.

When tie-in girth welds are not strength tested, they should be nondestructively tested in accordance with Section 192.241

Weld/Fusion Tests

As required by regulations, or at the request of an Operations Department, welds or

VGS Operating Procedures	Welding Effective Date: December 1, 2010 Page 7 of 8
---	---

fusions shall be inspected or tested for flaws. The type and number of tests shall be determined by regulatory requirements, type of pipe material or number of flaws found under inspection, if any.

Radiographic Inspection

When required by an Operations Department, radiographic inspection of welded joints shall be employed to inspect for weld flaws that are detrimental to the serviceability of the steel main. API Standard 1104 shall be used for identification of detrimental flaws within weld joints. Radiographic inspection shall be performed by experienced personnel contracted by the Company for such service.

Other Tests

Where situations warrant use of tests not generally used for weld or fusion inspection, an operations manager or supervisor shall have responsibility for selection of test methods.

Repair of Welds

Any defect found in a weld, which is determined to be detrimental to its serviceability, shall be either ground out and re-welded, or removed from the line as a cylinder and replaced by welding in a new section of pipe. Refer to Subpart E - Welding Procedures.

Weld Tests

I. Basic test.

The test is made on pipe 12 inches (305 millimeters) or less in diameter. The test weld must be made with the pipe in a horizontal fixed position so that the test weld includes at least one section of overhead position welding. The beveling, root opening, and other details must conform to the specifications of the procedure under which the welder is being qualified. Upon completion, the test weld is cut into four coupons and subjected to a root bend test. If, as a result of this test, two or more of the four coupons develop a crack in the weld material, or between the weld material and base metal, that is more than 1/8-inch (3.2 millimeters) long in any direction, the weld is unacceptable. Cracks that occur on the corner of the specimen during testing are not considered. A welder who successfully passes a butt-weld qualification test under this section shall be qualified to weld on all pipe diameters less than or equal to 12 inches.

II. Additional tests for welders of service line connections to mains.

A service line connection fitting is welded to a pipe section with the same diameter as a typical main. The weld is made in the same position as it is made in the field. The weld is unacceptable if it shows a serious undercutting or if it has rolled edges. The weld is tested by attempting to break the fitting off the run pipe. The weld is unacceptable if it breaks and shows incomplete fusion, overlap, or poor penetration at the junction of the fitting and run pipe.

III. Periodic tests for welders of small service lines.

Two samples of the welder's work, each about 8 inches (203 millimeters) long with the weld located approximately in the center, are cut from steel service line and tested as follows:

- (1) One sample is centered in a guided bend testing machine and bent to the contour of the die for a distance of 2 inches (51 millimeters) on each side of the weld. If the sample shows any breaks or cracks after removal from the bending machine, it is unacceptable.
- (2) The ends of the second sample are flattened and the entire joint subjected to a tensile strength test. If failure occurs adjacent to or in the weld metal, the weld is unacceptable. If a tensile strength testing machine is not available, this sample must also pass the bending test prescribed in subparagraph (1) of this paragraph.

DRAFT - NOT FOR CONSTRUCTION



Vermont Gas Systems, Inc.

WELDING PROCEDURE SPECIFICATION NUMBER _____

1. Welding Process	<input type="checkbox"/> Manual <input type="checkbox"/> Semi-automatic <input type="checkbox"/> Automatic <input type="checkbox"/> Gas metal arc <input type="checkbox"/> Shielded metal arc <input type="checkbox"/> Other
2. Material Description	
3. Diameter	<input type="checkbox"/> Less than 2 $\frac{3}{8}$ " O.D. <input type="checkbox"/> 2 $\frac{3}{8}$ " O.D. - 12 $\frac{3}{4}$ " O.D. <input type="checkbox"/> Over 12 $\frac{3}{4}$ " O.D.
4. Wall thickness	<input type="checkbox"/> Less than .188" <input type="checkbox"/> .188" thru .750" <input type="checkbox"/> Over .750"
5. Filler Metal Group	
6. Shielding	<input type="checkbox"/> Gas type: _____, Flow rate range _____ CFH; <input type="checkbox"/> Flux type: _____, Size _____
7. Position	<input type="checkbox"/> Roll <input type="checkbox"/> Fixed Pipe: <input type="checkbox"/> Horizontal <input type="checkbox"/> Vertical
8. Preheat	
9. Post Heat	
10. Joint Design	<input type="checkbox"/> V Bevel - see sketch below <input type="checkbox"/> Other - separate attached

Note: Number and sketch in the location of each weld bead

Bead Number	EI	Electrode	Voltage Range					Polarity	Weld'g Direction	Travel Speed Range-1PM									
											Current	AC	DC	STR	REV	DH	UH		
											Amperage Range								

11. Time Lapse	Root Bead to Second Bead: _____ Min; Second bead to succeeding beads: _____ Min.
12. Line-up clamp	<input type="checkbox"/> Internal <input type="checkbox"/> External
13. Line-up clamp removal	After minimum of <input type="checkbox"/> 50% <input type="checkbox"/> 100% <input type="checkbox"/> _____ % (specify) of root bead welding
14. Cleaning	<input type="checkbox"/> Power tools <input type="checkbox"/> Hand tools
Prepared by _____	Date _____
Approved by _____	Date _____



Vermont Gas
Systems, Inc.

WELDING PROCEDURE SPECIFICATION NUMBER API 1107 SLEEVE TEST

1. Welding Process	<input type="checkbox"/> Manual <input type="checkbox"/> Semi-automatic <input type="checkbox"/> Automatic <input type="checkbox"/> Gas metal arc <input checked="" type="checkbox"/> Shielded metal arc <input type="checkbox"/> Other
2. Material Description	ALL GRADES
3. Diameter	<input checked="" type="checkbox"/> Greater than 2 $\frac{3}{8}$ "O.D. <input type="checkbox"/> 2 $\frac{3}{8}$ "O.D. - 12 $\frac{3}{4}$ "O.D. <input type="checkbox"/> Over 12 $\frac{3}{4}$ " O.D.
4. Wall thickness	<input checked="" type="checkbox"/> Less than .188" <input checked="" type="checkbox"/> .188" thru .750" <input type="checkbox"/> Over .750"
5. Filler Metal Group	3-A5.1OR A5.5
6. Shielding	<input type="checkbox"/> Gas type: , Flow rate range <input checked="" type="checkbox"/> Flux type: IRON POWDER
7. Position	<input type="checkbox"/> Roll <input checked="" type="checkbox"/> Fixed Pipe: 45 DEGREE- 6G
8. Preheat	N/A
9. Post Heat	N/A
10. Joint Design	<input checked="" type="checkbox"/> V Bevel - see sketch below <input type="checkbox"/> Other - separate attached

Note: Number and sketch in the location of each weld bead

(SEE ATTACHED SKETCH)

Bead Number	Electrode		Voltage Range	Current			Polarity		Weld'g Direction		Travel Speed Range-1PM	
	Size	AWS Designation		Amperage Range	AC	DC	STR	REV	DH	UH		
1	1/8"	A5.1 7018	20/23	115/135		X		X	X		6/8	
2	1/8"	A5.1 7018	20/23	115/135		X		X	X		6/8	
3	1/8"	A5.1 7018	20/23	115/135		X		X	X		6/8	
11. Time Lapse			Root Bead to Second Bead: N/A Min; Second bead to succeeding beads: Min.									
12. Line-up clamp			<input type="checkbox"/> Internal <input checked="" type="checkbox"/> External									
13. Line-up clamp removal			After minimum of 50% <input type="checkbox"/> 100% <input type="checkbox"/> %(specify) of root bead welding									
14. Cleaning			<input checked="" type="checkbox"/> Power tools <input checked="" type="checkbox"/> Hand tools									
Prepared by LEE BROWN				Date 12/01/04				Approved by LEE BROWN				Date 12/01/04



Vermont Gas Systems, Inc. VGS-10-SS-3

PIPE WELDING PROCEDURE

1. Welding Process: Shielding Metal Arc
2. Test pipe/sleeve material grade: PLIDCO SOLEMATE .375 W.T. (Metalurgical attached)
3. Test pipe dia. And W.T.: 12" I.D. X .375 W.T.
4. Pipe grades qualified: ALL
5. Pipe dia. W.T. qualified: 12" I.D. 3/16"-3/4 W.T.
6. Weld joint design and parameters: Refer to page 2
7. Filler metal: AWS E7018
8. Electrical characteristics: DCRP
9. Position of weld sample: 45 degree angle-(6G)
10. Direction of welding: Vertical up for fillet welds; vertical up for groove welds.
11. Welding technique: Stringer
12. Line pressure during welding: Lower as needed
13. Line flow rate during welding: 3 FT/Sec. Max (if "0" flow is used, line must be completely filled.)
14. Line temperature during welding: Minimum 0 degrees F.
15. Method of weld cleaning: Power Brushing
16. Ambient test welding temperature: 70 degrees F.
17. Preheat temperature: 150 degrees F. minimum-350 degrees F. maximum to dry weld area prior to welding
18. Destructive test results: Refer to welder qualifications
19. Fluid flow for qualification test 1 GPM water.

THIS PROCEDURE WAS PREPARED IN ACCORDANCE WITH AND MEETS THE REQUIREMENTS OF API 1107, NINETEENTH EDITION.



VGS Representative

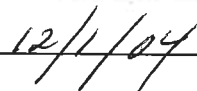

Date

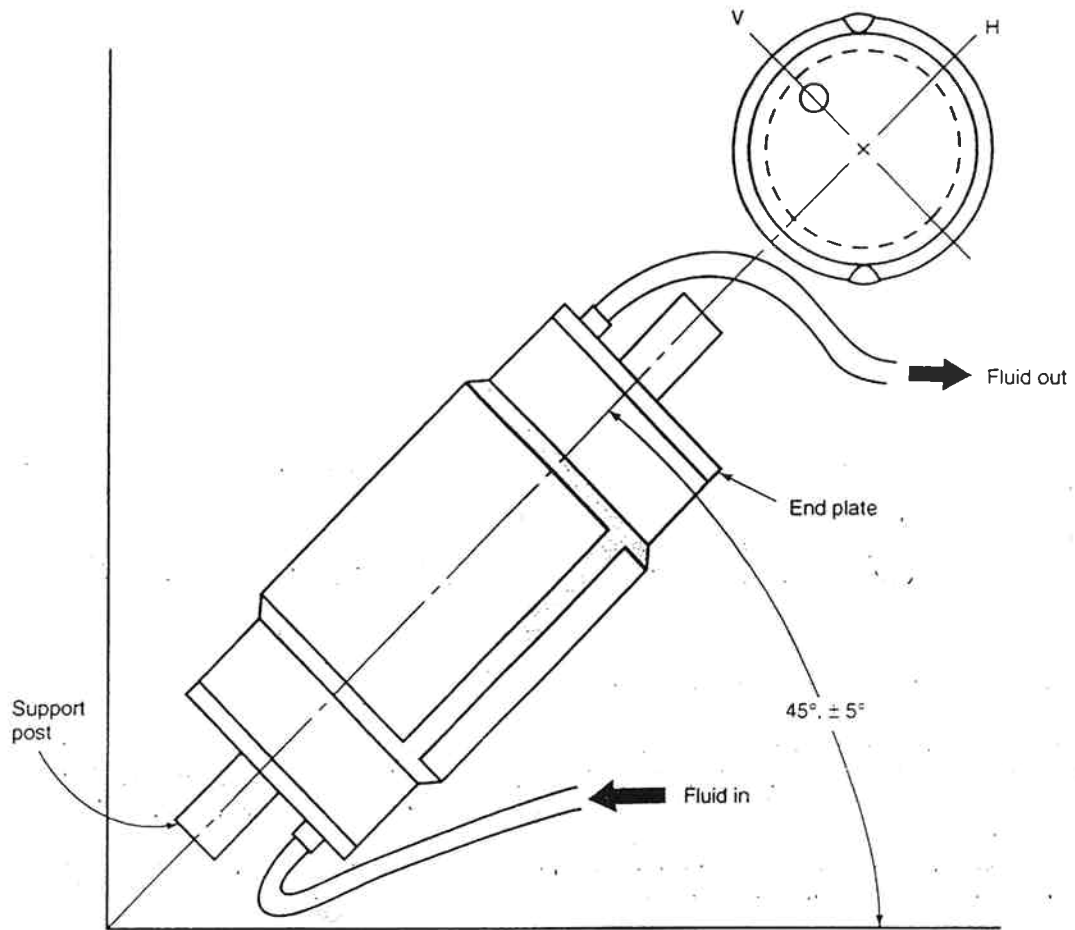

Note: This test position qualifies the procedure for all positions. Tests may be performed in other positions which will qualify the procedure for that position only.

Figure B-2—Suggested Procedure and Welder Qualification Test Assembly



Vermont Gas
Systems, Inc.

WELDING PROCEDURE <3/16" TO > 3/16"
SPECIFICATION NUMBER PIPE DIAMETER <2 3/8"

1. Welding Process	<input type="checkbox"/> Manual <input checked="" type="checkbox"/> Shielded metal arc	<input type="checkbox"/> Semi-automatic <input type="checkbox"/> Other	<input type="checkbox"/> Automatic	<input type="checkbox"/> Gas metal arc
2. Material Description	GRADE "B" .140-.191			
3. Diameter	<input checked="" type="checkbox"/> Less than 2 3/8" O.D. <input type="checkbox"/> 2 3/8" O.D. - 12 3/4" O.D. <input type="checkbox"/> Over 12 3/4" O.D.			
4. Wall thickness	<input type="checkbox"/> Less than .188" <input checked="" type="checkbox"/> .140 thru .500 <input type="checkbox"/> Over .750"			
5. Filler Metal Group	1-A5.1			
6. Shielding	<input type="checkbox"/> Gas type: , Flow rate range		<input type="checkbox"/> Flux type: CELLULSE	
7. Position	<input type="checkbox"/> Roll <input checked="" type="checkbox"/> Fixed		Pipe: 45 DEGREE- 6G	
8. Preheat	As required			
9. Post Heat	N/A			
10. Joint Design	<input checked="" type="checkbox"/> X V Bevel - see sketch below <input type="checkbox"/> Other - separate attached			

Note: Number and sketch in the location of each weld bead

ASME B31.8-1995 Edition

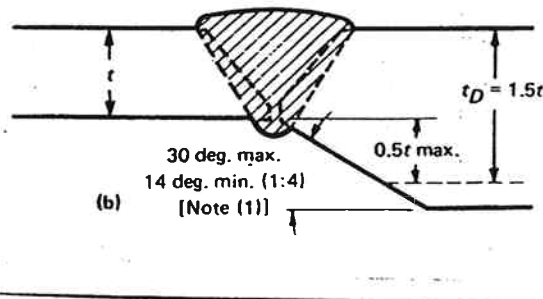

Bead Number	Electrode		Voltage Range	Current			Polarity		Weld'g Direction		Travel Speed Range-1PM
	Size	AWS Designation		Amperage Range	AC	DC	STR	REV	DH	UH	
1	3/32"	A5.1 6010	20/23	50/80		X		X	X		6/12
2	3/32"	A5.1 6010	20/23	50/80		X		X	X		6/12
3	3/32"	A5.1 6010	20/23	50/80		X		X	X		6/12
11. Time Lapse	Root Bead to Second Bead: 5 Min; Second bead to succeeding beads: 5 Min.										
12. Line-up clamp	<input type="checkbox"/> Internal <input checked="" type="checkbox"/> External										
13. Line-up clamp removal	After minimum of <input checked="" type="checkbox"/> 50% <input type="checkbox"/> 100% <input type="checkbox"/> %(specify) of root bead welding										
14. Cleaning	<input checked="" type="checkbox"/> X Power tools <input checked="" type="checkbox"/> X Hand tools										
Prepared by LEE BROWN			Date 10/16/04			Approved by LEE BROWN			Date 10/06/04		



WELDING PROCEDURE SPECIFICATION NUMBER 16" X-65 BUTT WELD

Vermont Gas Systems, Inc.

1. Welding Process	<input checked="" type="checkbox"/> Manual <input type="checkbox"/> Semi-automatic <input type="checkbox"/> Automatic <input type="checkbox"/> Gas metal Arc <input checked="" type="checkbox"/> Shielded metal arc <input type="checkbox"/> Other
2. Material Description	API 5L X-65
3. Diameter	<input type="checkbox"/> Less than 2 $\frac{3}{8}$ " O.D. <input checked="" type="checkbox"/> 2 $\frac{3}{8}$ " O.D. - 12 $\frac{3}{4}$ " O.D. <input checked="" type="checkbox"/> Over 12 $\frac{3}{4}$ " O.D.
4. Wall thickness	<input type="checkbox"/> Less than .188" <input checked="" type="checkbox"/> .188" thru .750" <input type="checkbox"/> Over .750"
5. Filler Metal Group	1-A5.1, 2-A5.5
6. Shielding	<input type="checkbox"/> Gas type: , Flow rate range CFH; <input checked="" type="checkbox"/> Flux type: , Size
7. Position	<input type="checkbox"/> Roll <input checked="" type="checkbox"/> Fixed Pipe: 6 G
8. Preheat	250 DEG F, IF BELOW 40 300 DEG F
9. Post Heat	N/A
10. Joint Design	<input checked="" type="checkbox"/> V Bevel - see sketch below <input type="checkbox"/> Other - separate attached

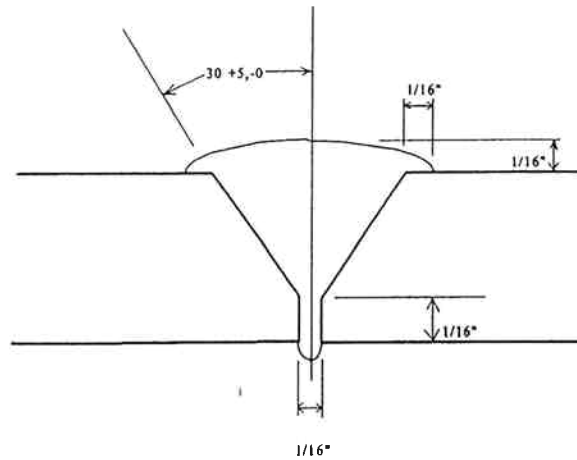

Note: Number and sketch in the location of each weld bead

Bead Number	Electrode		Voltage Range	Current			Polarity		Weld'g Direction		Travel Speed Range-1PM
	Size	AWS Designation		Amperage Range	AC	DC	STR	REV	DH	UH	
1	5/32	A5.1 6010	25-28	130-160		X		X	X		6-16
2	5/32	A5.1 6010	25-28	130-160		X		X	X		6-16
3,4	3/16	A5.5 8010G	25-28	160-190		X		X	X		6-16
11. Time Lapse			Root Bead to Second Bead: 5 Min; Second bead to succeeding beads: Min.								
12. Line-up clamp			<input type="checkbox"/> Internal <input checked="" type="checkbox"/> External								
13. Line-up clamp removal			After minimum of <input checked="" type="checkbox"/> 50% <input type="checkbox"/> 100% <input type="checkbox"/> % (specify) of root bead welding								
14. Cleaning			<input checked="" type="checkbox"/> Power tools <input type="checkbox"/> Hand tools								



WELDING PROCEDURE SPECIFICATION NUMBER 16" BRANCH TEE

Vermont Gas Systems, Inc.

1. Welding Process	<input checked="" type="checkbox"/> Manual <input checked="" type="checkbox"/> Shielded metal arc <input type="checkbox"/> Semi-automatic <input type="checkbox"/> Other <input type="checkbox"/> Automatic <input type="checkbox"/> Gas metal Arc
2. Material Description	API 5L X-65
3. Diameter	<input type="checkbox"/> Less than 2 3/8" O.D. <input checked="" type="checkbox"/> 2 3/8" O.D. - 12 3/4" O.D. <input checked="" type="checkbox"/> Over 12 3/4" O.D.
4. Wall thickness	<input type="checkbox"/> Less than .188" <input checked="" type="checkbox"/> .188" thru .750" <input type="checkbox"/> Over .750"
5. Filler Metal Group	1-A5.1, 2-A5.5
6. Shielding	<input type="checkbox"/> Gas type: _____, Flow rate range _____ CFH; <input checked="" type="checkbox"/> Flux type: _____, Size _____
7. Position	<input type="checkbox"/> Roll <input checked="" type="checkbox"/> Fixed Pipe: HORIZONTAL
8. Preheat	250 DEG F, IF BELOW 40 300 DEG F
9. Post Heat	N/A
10. Joint Design	<input checked="" type="checkbox"/> V Bevel - see sketch below <input type="checkbox"/> Other - separate attached

Note: Number and sketch in the location of each weld bead

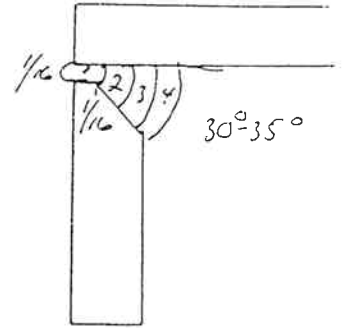
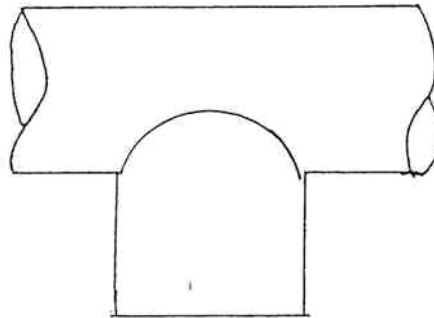

Bead Number	Electrode		Voltage Range	Current			Polarity		Weld'g Direction		Travel Speed Range-1PM
	Size	AWS Designation		Amperage Range	AC	DC	STR	REV	DH	UH	
1	5/32	A5.1 6010	25-28	130-160		X		X	X		6-16
2	5/32	A5.1 6010	25-28	130-160		X		X	X		6-16
3,4	3/16	A5.5 8010G	25-28	160-190		X		X	X		6-16

11. Time Lapse Root Bead to Second Bead: 5 Min; Second bead to succeeding beads: _____ Min.

Line-up clamp Internal External

13. Line-up clamp removal After minimum of 50% 100% _____ % (specify) of root bead welding

14. Cleaning Power tools Hand tools

Prepared by *John Brown* Date 7/11/02 Approved by _____ Date _____



WELDING PROCEDURE SPECIFICATION NUMBER 16" X-65 DELAY

Vermont Gas Systems, Inc.

1. Welding Process	<input checked="" type="checkbox"/> Manual <input type="checkbox"/> Semi-automatic <input type="checkbox"/> Automatic <input type="checkbox"/> Gas metal Arc <input checked="" type="checkbox"/> Shielded metal arc <input type="checkbox"/> Other
2. Material Description	API 5L X-65
3. Diameter	<input type="checkbox"/> Less than 2 3/8" O.D. <input checked="" type="checkbox"/> 2 3/8" O.D. - 12 3/4" O.D. <input checked="" type="checkbox"/> Over 12 3/4" O.D.
4. Wall thickness	<input type="checkbox"/> Less than .188" <input checked="" type="checkbox"/> .188" thru .750" <input type="checkbox"/> Over .750"
5. Filler Metal Group	1-A5.1, 2-A5.5
6. Shielding	<input type="checkbox"/> Gas type: _____, Flow rate range _____ CFH; <input checked="" type="checkbox"/> Flux type: _____, Size _____
7. Position	<input type="checkbox"/> Roll <input checked="" type="checkbox"/> Fixed Pipe: 6 G
8. Preheat	250 DEG F, IF BELOW 40 300 DEG F
9. Post Heat	N/A
10. Joint Design	<input checked="" type="checkbox"/> V Bevel - see sketch below <input type="checkbox"/> Other - separate attached

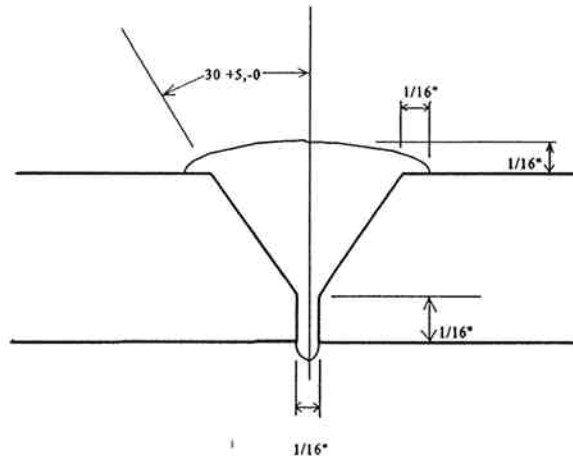

Note: Number and sketch in the location of each weld bead

Bead Number	Electrode		Voltage Range	Current			Polarity		Weld'g Direction		Travel Speed Range-IPM
	Size	AWS Designation		Amperage Range	AC	DC	STR	REV	DH	UH	
1	5/32	A5.1 6010	25-28	130-160		X		X	X		6-16
2	5/32	A5.1 6010	25-28	130-160		X		X	X		6-16

11. Time Lapse	Root Bead to Second Bead: 5 Min; Second bead to succeeding beads: _____ Min.
12. Line-up clamp	<input type="checkbox"/> Internal <input checked="" type="checkbox"/> External
13. Line-up clamp removal	After minimum of <input checked="" type="checkbox"/> 50% <input type="checkbox"/> 100% <input type="checkbox"/> _____ % (specify) of root bead welding
14. Cleaning	<input checked="" type="checkbox"/> Power tools <input type="checkbox"/> Hand tools
Prepared by <i>Lubrown</i>	Date <i>7/11/02</i>
Approved by _____	Date _____



WELDING PROCEDURE SPECIFICATION NUMBER 16" X-65 DELAY

Vermont Gas Systems, Inc.

1. Welding Process	<input checked="" type="checkbox"/> Manual <input checked="" type="checkbox"/> Shielded metal arc <input type="checkbox"/> Semi-automatic <input type="checkbox"/> Other <input type="checkbox"/> Automatic <input type="checkbox"/> Gas metal Arc
2. Material Description	API 5L X-65
3. Diameter	<input type="checkbox"/> Less than 2 $\frac{3}{8}$ " O.D. <input checked="" type="checkbox"/> 2 $\frac{3}{8}$ " O.D. - 12 $\frac{3}{4}$ " O.D. <input checked="" type="checkbox"/> Over 12 $\frac{3}{4}$ " O.D.
4. Wall thickness	<input type="checkbox"/> Less than .188" <input checked="" type="checkbox"/> .188" thru .750" <input type="checkbox"/> Over .750"
5. Filler Metal Group	1-A5.1, 2-A5.5
6. Shielding	<input type="checkbox"/> Gas type: _____, Flow rate range _____ CFH; <input checked="" type="checkbox"/> Flux type: _____, Size _____
7. Position	<input type="checkbox"/> Roll <input checked="" type="checkbox"/> Fixed Pipe: 6 G
8. Preheat	250 DEG F, IF BELOW 40 300 DEG F
9. Post Heat	N/A
10. Joint Design	<input checked="" type="checkbox"/> V Bevel - see sketch below <input type="checkbox"/> Other - separate attached

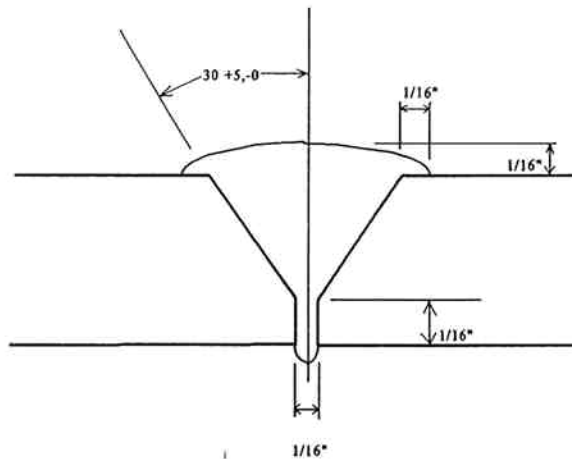

Note: Number and sketch in the location of each weld bead

Bead Number	Electrode		Voltage Range	Current			Polarity		Weld'g Direction		Travel Speed Range-1PM
	Size	AWS Designation		Amperage Range	AC	DC	STR	REV	DH	UH	
1	3/16	A5.5 8010G	25-28	130-160		X		X	X		6-16
2	3/16	A5.5 8010G	25-28	130-160		X		X	X		6-16

11. Time Lapse	Root Bead to Second Bead: 5 Min; Second bead to succeeding beads: _____ Min.
12. Line-up clamp	<input type="checkbox"/> Internal <input checked="" type="checkbox"/> External
13. Line-up clamp removal	After minimum of <input checked="" type="checkbox"/> 50% <input type="checkbox"/> 100% <input type="checkbox"/> _____ % (specify) of root bead welding
14. Cleaning	<input checked="" type="checkbox"/> Power tools <input type="checkbox"/> Hand tools
Prepared by	Date <u>7/22/02</u> Approved by _____ Date _____



Vermont Gas
Systems, Inc.

WELDING PROCEDURE <3/16" TO > 3/16"
SPECIFICATION NUMBER PIPE DIAMETER .2 3/8"

1. Welding Process	<input type="checkbox"/> Manual X Shielded metal arc	<input type="checkbox"/> Semi-automatic <input type="checkbox"/> Other	<input type="checkbox"/> Automatic	<input type="checkbox"/> Gas metal arc
2. Material Description	GRADE "B" .154-.218			
3. Diameter	X Greater than 2 3/8" O.D. <input type="checkbox"/> 2 3/8" O.D. - 12 3/4" O.D. <input type="checkbox"/> Over 12 3/4" O.D.			
4. Wall thickness	<input type="checkbox"/> Less than .188" X .188" thru .750" <input type="checkbox"/> Over .750"			
5. Filler Metal Group	1-A5.1			
6. Shielding	<input type="checkbox"/> Gas type: , Flow rate range <input type="checkbox"/> Flux type: CELLULOSE			
7. Position	<input type="checkbox"/> Roll X Fixed Pipe: 45 DEGREE- 6G			
8. Preheat	As required			
9. Post Heat	N/A			
10. Joint Design	X V Bevel - see sketch below <input type="checkbox"/> Other - separate attached			

Note: Number and sketch in the location of each weld bead

ASME B31.8-1995 Edition

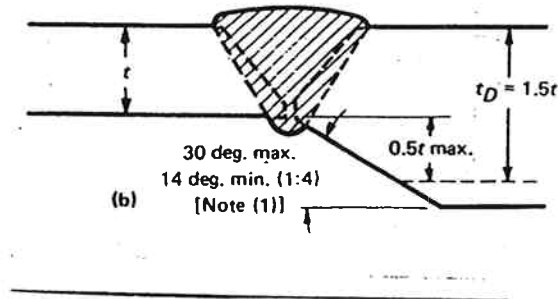

Bead Number	Electrode		Voltage Range	Current			Polarity		Weld'g Direction		Travel Speed Range-1PM	
	Size	AWS Designation		Amperage Range	AC	DC	STR	REV	DH	UH		
1	3/32"	A5.1 6010	20/23	50/80		X		X	X		6/12	
2	3/32"	A5.1 6010	20/23	50/80		X		X	X		6/12	
3	3/32"	A5.1 6010	20/23	50/80		X		X	X		6/12	
11. Time Lapse	Root Bead to Second Bead: 5 Min; Second bead to succeeding beads: 5 Min.											
12. Line-up clamp	<input type="checkbox"/> Internal X External											
13. Line-up clamp removal	After minimum of X 50% <input type="checkbox"/> 100% <input type="checkbox"/> %(specify) of root bead welding											
14. Cleaning	X Power tools X Hand tools											
Prepared by LEE BROWN				Date 10/16/04				Approved by LEE BROWN				Date 10/06/04



Vermont Gas
Systems, Inc.

WELDING PROCEDURE SPECIFICATION NUMBER 7018 BUTT WELD

1. Welding Process	X Manual <input type="checkbox"/> Semi-automatic <input type="checkbox"/> Automatic <input type="checkbox"/> Gas metal arc X Shielded metal arc <input type="checkbox"/> Other
2. Material Description	GRADE "B" .375 wt.
3. Diameter	X Less than 2 $\frac{3}{8}$ " O.D. X 2 $\frac{3}{8}$ " O.D. - 12 $\frac{3}{4}$ " O.D. X Over 12 $\frac{3}{4}$ " O.D.
4. Wall thickness	X Less than .188" X .188" thru .750" X Over .750"
5. Filler Metal Group	GROUP 3, A5.1, A5.5
6. Shielding	<input type="checkbox"/> Gas type: , Flow rate range Flux type: IRON POWDER
7. Position	<input type="checkbox"/> Roll X Fixed Pipe: 45 DEGREE- 6G
8. Preheat	N/A
9. Post Heat	N/A
10. Joint Design	X V Bevel - see sketch below <input type="checkbox"/> Other - separate attached

Note: Number and sketch in the location of each weld bead

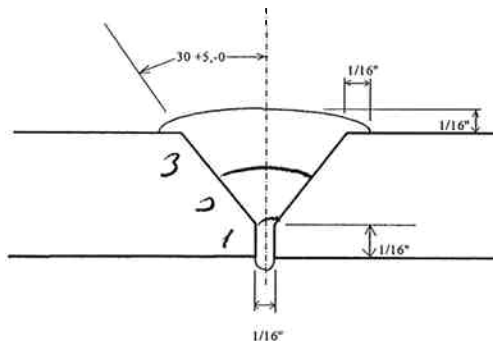

Bead Number	Electrode		Voltage Range	Current			Polarity		Weld'g Direction		Travel Speed Range-1PM
	Size	AWS Designation		Amperage Range	AC	DC	STR	REV	DH	UH	
1	1/8"	A5.1 6010	20/23	90/120		X		X	X		6/16
2	3/32"	A5.5 7018	20/23	80/100		X		X		X	6/8
3+	3/32"	A5.5 7018	20/23	80/100		X		X		X	6/8

11. Time Lapse	Root Bead to Second Bead: 5 Min; Second bead to succeeding beads: 5 Min.
12. Line-up clamp	<input type="checkbox"/> Internal X External
13. Line-up clamp removal	After minimum of X 50% <input type="checkbox"/> 100% <input type="checkbox"/> %(specify) of root bead welding
14. Cleaning	X Power tools X Hand tools

Prepared by LEE BROWN	Date 9/14/01	Approved by LEE BROWN	Date 9/14/01
-----------------------	--------------	-----------------------	--------------



Vermont Gas Systems, Inc.

WELDING PROCEDURE SPECIFICATION NUMBER 6010 BUTT WELD

1. Welding Process	<input checked="" type="checkbox"/> Manual <input type="checkbox"/> Semi-automatic <input type="checkbox"/> Automatic <input type="checkbox"/> Gas metal arc <input checked="" type="checkbox"/> Shielded metal arc <input type="checkbox"/> Other
2. Material Description	GRADE "B" .375wt.
3. Diameter	<input checked="" type="checkbox"/> Less than 2 $\frac{3}{8}$ " O.D. <input checked="" type="checkbox"/> 2 $\frac{3}{8}$ " O.D. - 12 $\frac{3}{4}$ " O.D. <input checked="" type="checkbox"/> Over 12 $\frac{3}{4}$ " O.D.
4. Wall thickness	<input checked="" type="checkbox"/> Less than .188" <input checked="" type="checkbox"/> .188" thru .750" <input checked="" type="checkbox"/> Over .750"
5. Filler Metal Group	GROUP 1 A5.1
6. Shielding	<input type="checkbox"/> Gas type: _____, Flow rate range _____ Flux type: CELLULOSE _____, Size _____
7. Position	<input type="checkbox"/> Roll <input checked="" type="checkbox"/> Fixed Pipe: 45 DEGREE 6-G
8. Preheat	N/A
9. Post Heat	N/A
10. Joint Design	<input checked="" type="checkbox"/> V Bevel - see sketch below <input type="checkbox"/> Other - separate attached

Note: Number and sketch in the location of each weld bead

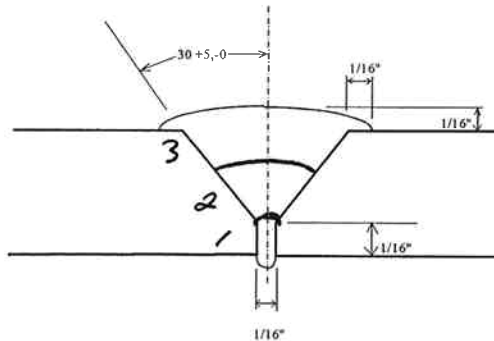

Bead Number	Electrode		Voltage Range	Current			Polarity		Weld'g Direction		Travel Speed Range-1PM
	Size	AWS Designation		Amperage Range	AC	DC	STR	REV	DH	UH	
1	1/8"	A5.1 6010	20/23	90/120		X		X	X		6/16
2	1/8"	A5.1 6010	20/23	90/120		X		X	X		6/16
3+	1/8"	A5.1 6010	20/23	90/120		X		X	X		6/16

11. Time Lapse	Root Bead to Second Bead: 5 Min; Second bead to succeeding beads: 5 Min.
12. Line-up clamp	<input type="checkbox"/> Internal <input checked="" type="checkbox"/> External
13. Line-up clamp removal	After minimum of <input checked="" type="checkbox"/> 50% <input type="checkbox"/> 100% <input type="checkbox"/> _____ % (specify) of root bead welding
14. Cleaning	<input checked="" type="checkbox"/> Power tools <input checked="" type="checkbox"/> Hand tools
Prepared by LEE BROWN Date 9/14/01 Approved by LEE BROWN Date 9/14/01	



Vermont Gas
Systems, Inc.

WELDING PROCEDURE SPECIFICATION NUMBER BRANCH TEE 6010

1. Welding Process	<input checked="" type="checkbox"/> Manual <input type="checkbox"/> Semi-automatic <input type="checkbox"/> Automatic <input type="checkbox"/> Gas metal arc <input checked="" type="checkbox"/> Shielded metal arc <input type="checkbox"/> Other
2. Material Description	GRADE "B" .375wt.
3. Diameter	<input checked="" type="checkbox"/> Less than 2 $\frac{3}{8}$ " O.D. <input checked="" type="checkbox"/> 2 $\frac{3}{8}$ " O.D. - 12 $\frac{3}{4}$ " O.D. <input checked="" type="checkbox"/> Over 12 $\frac{3}{4}$ " O.D.
4. Wall thickness	<input checked="" type="checkbox"/> Less than .188" <input checked="" type="checkbox"/> .188" thru .750" <input checked="" type="checkbox"/> Over .750"
5. Filler Metal Group	GROUP 1, A5.1
6. Shielding	<input type="checkbox"/> Gas type: _____, Flow rate range _____ CFH; Flux type: CELLULOSE _____, Size _____
7. Position	<input type="checkbox"/> Roll <input checked="" type="checkbox"/> Fixed Pipe: HORIZONTAL
8. Preheat	N/A
9. Post Heat	N/A
10. Joint Design	<input checked="" type="checkbox"/> V Bevel - see sketch below <input type="checkbox"/> Other - separate attached

Note: Number and sketch in the location of each weld bead

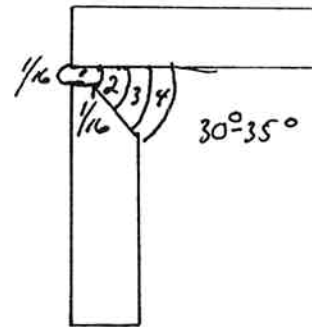
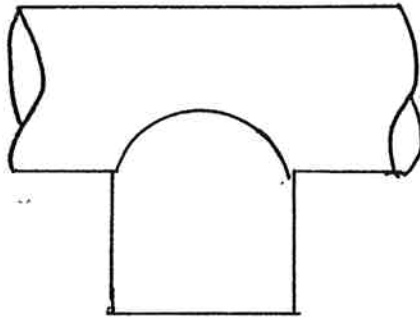

Bead Number	Electrode		Voltage Range	Current			Polarity		Weld'g Direction		Travel Speed Range-1PM	
	Size	AWS Designation		Amperage Range	AC	DC	STR	REV	DH	UH		
1	1/8"	A5.1, 6010	20-23	90-120		X		X	X		6-16	
2	1/8"	A5.1, 6010	20-23	90-120		X		X	X		6-16	
3	1/8"	A5.1,6010	20-23	90-120		X		X	X		6-16	
11. Time Lapse			Root Bead to Second Bead: 5 Min; Second bead to succeeding beads: 5 Min.									
12. Line-up clamp			<input type="checkbox"/> Internal External									
13. Line-up clamp removal			After minimum of 50% <input type="checkbox"/> 100% <input type="checkbox"/> N/A _____%(specify) of root bead welding									
14. Cleaning			<input checked="" type="checkbox"/> Power tools <input checked="" type="checkbox"/> Hand tools									
Prepared by LEE BROWN				Date 9/14/01				Approved by LEE BROWN				Date 9/14/01



Vermont Gas
Systems, Inc.

WELDING PROCEDURE SPECIFICATION NUMBER BRANCH TEE 7018

1. Welding Process	<input checked="" type="checkbox"/> Manual <input type="checkbox"/> Semi-automatic <input type="checkbox"/> Automatic <input type="checkbox"/> Gas metal arc <input checked="" type="checkbox"/> Shielded metal arc <input type="checkbox"/> Other
2. Material Description	GRADE "B" .375 wt.
3. Diameter	<input checked="" type="checkbox"/> Less than 2 $\frac{3}{8}$ " O.D. <input checked="" type="checkbox"/> 2 $\frac{3}{8}$ " O.D. - 12 $\frac{3}{4}$ " O.D. <input checked="" type="checkbox"/> Over 12 $\frac{3}{4}$ " O.D.
4. Wall thickness	<input checked="" type="checkbox"/> Less than .188" <input checked="" type="checkbox"/> .188" thru .750" <input checked="" type="checkbox"/> Over .750"
5. Filler Metal Group	A5.1, A5.5 GROUP 3
6. Shielding	<input type="checkbox"/> Gas type: _____, Flow rate range _____ CFH; <input checked="" type="checkbox"/> Flux type: IRON POWDER
7. Position	<input type="checkbox"/> Roll <input checked="" type="checkbox"/> Fixed Pipe: <input checked="" type="checkbox"/> Horizontal <input type="checkbox"/> Vertical
8. Preheat	N/A
9. Post Heat	N/A
10. Joint Design	<input checked="" type="checkbox"/> V Bevel - see sketch below <input type="checkbox"/> Other - separate attached

Note: Number and sketch in the location of each weld bead

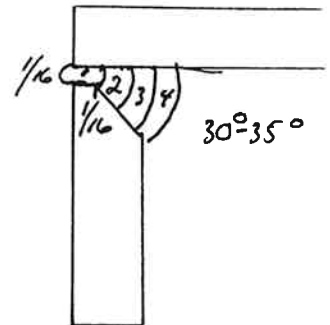
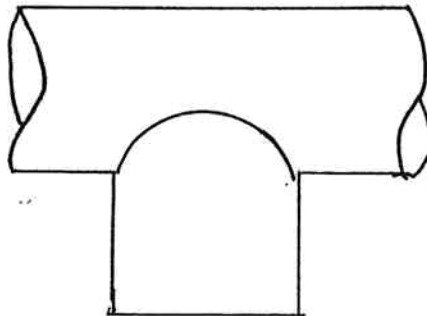

Bead Number	Electrode		Voltage Range	Current			Polarity		Weld'g Direction		Travel Speed Range-1PM
	Size	AWS Designation		Amperage Range	AC	DC	STR	REV	DH	UH	
1	1/8"	A5.1-6010	22-25	90-120		X		X	X		6-16
2	3/32"	A5.5-7018	20-23	80-100		X		X		X	6-8
3+	3/32"	A5.5-7018	20-23	80-100		X		X		X	6-8

11. Time Lapse	Root Bead to Second Bead: 5 Min; Second bead to succeeding beads: 5 Min.		
12. Line-up clamp	N/A Internal N/A External		
13. Line-up clamp removal	After minimum of <input type="checkbox"/> 50% <input type="checkbox"/> 100% N/A % (specify) of root bead welding		
14. Cleaning	<input checked="" type="checkbox"/> Power tools <input checked="" type="checkbox"/> Hand tools		
Prepared by LEE BROWN	Date 9/14/01	Approved by LEE BROWN	Date 9/14/01



Vermont Gas
Systems, Inc.

WELDING PROCEDURE SPECIFICATION NUMBER GRADE "B" x X-52

1. Welding Process	<input checked="" type="checkbox"/> Manual <input type="checkbox"/> Semi-automatic <input type="checkbox"/> Automatic <input type="checkbox"/> Gas metal arc <input checked="" type="checkbox"/> Shielded metal arc <input type="checkbox"/> Other
2. Material Description	
3. Diameter	<input type="checkbox"/> Less than 2 ³ / ₈ " O.D. <input checked="" type="checkbox"/> 2 ³ / ₈ " O.D. - 12 ³ / ₄ " O.D. <input type="checkbox"/> Over 12 ³ / ₄ " O.D.
4. Wall thickness	<input type="checkbox"/> Less than .188" <input checked="" type="checkbox"/> .188" thru .750" <input type="checkbox"/> Over .750"
5. Filler Metal Group	
6. Shielding	<input type="checkbox"/> Gas type: , Flow rate range CFH; Flux type: cellulose
7. Position	<input type="checkbox"/> Roll <input checked="" type="checkbox"/> Fixed Pipe: 45 degree / 6G I
8. Preheat	250 degrees below 40 degrees
9. Post Heat	N/A
10. Joint Design	<input checked="" type="checkbox"/> V Bevel - see sketch below <input type="checkbox"/> Other - separate attached

Note: Number and sketch in the location of each weld bead

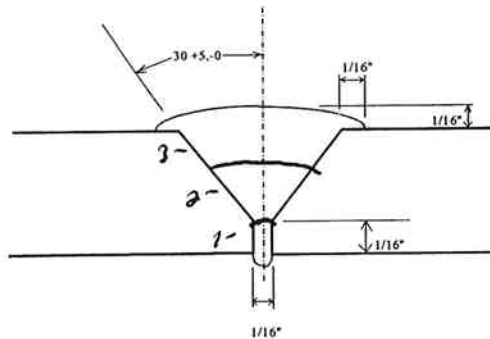

Bead Number	Electrode		Voltage Range	Current			Polarity		Weld'g Direction		Travel Speed Range-1PM
	Size	AWS Designation		Amperage Range	AC	DC	STR	REV	DH	UH	
1	1/8"	1-A5.1	25-28	90-120		X		X	X		6-16
2	5/32"	1-A5.1	25-28	130-160		X		X	X		6-16
3	5/32"	1-A5.1	25-28	130-160		X		X	X		6-16
11. Time Lapse			Root Bead to Second Bead: 5 Min; Second bead to succeeding beads: 5 Min.								
12. Line-up clamp			<input type="checkbox"/> Internal <input checked="" type="checkbox"/> External								
13. Line-up clamp removal			After minimum of <input checked="" type="checkbox"/> 50% <input type="checkbox"/> 100% <input type="checkbox"/> %(specify) of root bead welding								
14. Cleaning			<input checked="" type="checkbox"/> Power tools <input type="checkbox"/> Hand tools								
Prepared by LEE BROWN				Date 5/12/05		Approved by LEE BROWN				Date 5/12/05	

VERMONT GAS ADDISON NATURAL GAS PROJECT

SCOPE OF WORK AND SPECIFICATIONS

1. GENERAL

- a. The work shall be carried out in accordance with these Construction Specifications, The U.S. Department of Transportation Title 49CFR Part 192 – Transportation of Natural Gas and Other Gas by Pipeline, ASME B31.8 and API 1104. In addition the WORK shall be performed in strict compliance with the **CONFORMED DOCUMENTS**, good engineering practice and industry accepted pipeline construction and installation techniques, and all applicable rules and regulations. The work shall strictly adhere to the most current version of the Vermont Gas Systems (VGS), Inc. Operation and Maintenance Manual and Operating Procedures. The requirements detailed in the VGS Operation and Maintenance Manual and Operating Procedures shall supersede any other specifications provided with the Project Manual.
- b. The Addison Natural Gas Project has been divided into four contracts; Transmission, Horizontal Directional Drilling, Meter & Regulation Stations, and Distribution. It is a requirement of the Transmission Contract to coordinate and cooperate with other Contractors working on other/adjacent areas of the project.

2. SURVEYS

- a. All pre-construction, construction, and as-built survey shall be the responsibility of the **COMPANY**, and jointly coordinated between the **CONTRACTOR** and the **COMPANY**. **CONTRACTOR** is responsible for coordinating the survey needs via the designated **COMPANY** representative, so it does not impact work.
- b. The **COMPANY** shall reserve the right to make any minor changes in the pipeline route and such changes shall in no manner alter the terms of compensation payable under this **CONTRACT** except as they are affected by linear measurements of the work completed.
- c. The **COMPANY** shall stake the edges of the **RIGHT-OF-WAY** at regular intervals. These stakes shall remain along the **RIGHT-OF-WAY** for the duration of the job and be removed as part of final clean up operations when authorized by **COMPANY**.
- d. The **CONTRACTOR** shall be held responsible for the preservation of all stakes and field markings. If any of the stakes or field markings are disturbed by the contractor, the cost of replacing them shall be borne by the **CONTRACTOR**. When it becomes necessary to move such stakes, the **CONTRACTOR** will relocate them to the spoil side of the **RIGHT-OF-WAY** in a line approximately perpendicular to the centerline of the pipeline location and opposite the original location of the stake.

Add "ANGP Scope of Work and Narrative Specification" for a prefix to the page #

- e. The **CONTRACTOR** shall perform necessary field surveys for the proper grading of the trench and the bending of pipe, and for other such pipeline installations.
- f. Refer to the following for additional information:
 - A. Specification 017839 – Project Record Documents
 - B. Supplemental Conditions

3. RIGHTS-OF-WAY

- a. The CONSTRUCTION RIGHT-OF-WAY shall be as shown on the DRAWINGS with such minor modifications as may be approved in the field by the **COMPANY**. The CONSTRUCTION RIGHT-OF-WAY may include a portion of the existing RIGHT-OF-WAY, new easements, and/or ADDITIONAL TEMPORARY WORK SPACE (ATWS) where such have been acquired by the **COMPANY**. In addition the standard CONSTRUCTION RIGHT-OF-WAY widths may be reduced substantially in certain areas, as indicated on the DRAWINGS.
- b. In negotiating any **CONTRACTOR** obtained third party agreement, the **COMPANY** will require a **COMPANY AGENT** accompany the **CONTRACTOR AGENT**. **All agreements shall be in writing and furnished to the COMPANY prior to any authorized activity.**
- c. The **COMPANY** will procure RIGHTS-OF-WAY for construction of said pipeline. For the **CONTRACTOR'S** construction operations, the **COMPANY** will provide construction RIGHT-OF-WAY that, unless specified otherwise in construction permits, RIGHT-OF-WAY Agreements, CONSTRUCTION LINE LISTS or on DRAWINGS will typically consist of 25ft of TEMPORARY WORK SPACE. **Working over existing gas pipelines shall be strictly prohibited.** The **COMPANY** will provide and furnish necessary federal, state, city, or other highway opening permits, and environmental permits for construction of the pipeline as proposed in the DRAWINGS and SPECIFICATIONS. **CONTRACTOR** shall be responsible for obtaining all travel or over the road permits relating to the hauling of their equipment, and company supplied pipe and/or materials.
- d. TEMPORARY WORK SPACE as has been shown on the DRAWINGS has been secured by the **COMPANY**. The TEMPORARY WORK SPACE limits will be strictly enforced throughout the project. Should any violations occur, the crew in violation, at the discretion of the **COMPANY**, will be shut down until further assessment by the **COMPANY**. All cost associated with a work stoppage due to RIGHT-OF-WAY limit violations shall be borne by the **CONTRACTOR**.
- e. When acquiring RIGHT-OF-WAY along the route of the pipeline, it may have been necessary at various locations for the **COMPANY** to agree to certain special requirements by landowners and tenants. Special requirements shall be noted on the CONSTRUCTION LINE LISTS and shall be made available to the **CONTRACTOR**. The **CONTRACTOR** shall comply with these special requirements at no additional cost to the **COMPANY**. If complete CONSTRUCTION LINE LISTS

are incomplete at the time of the bid, items requiring special attention will be negotiated with the **CONTRACTOR** at the time that such items are identified.

- f. At certain locations the pipeline may be routed adjacent to or across other pipelines, highways, or telephone poles and wires, power poles and wires, embankments, cliffs, rivers, trees or other obstacles which may physically restrict or limit the use of the RIGHT-OF-WAY. In some cases such physical confinement may necessitate special methods of construction of the pipeline. Use of these special methods (for example rubber tired vehicles, etc.) shall be at the discretion of the **CONTRACTOR** at no additional compensation to the **CONTRACTOR**. Use of special construction methods must be approved by the **COMPANY**.
- g. The **CONTRACTOR** shall determine in advance the location and required clearance of existing underground facilities which may be encountered and determine any necessary changes in grade or location. The location of underground structures as shown on the DRAWINGS shall be only for assistance of the **CONTRACTOR**. The ultimate responsibility for locating such underground facilities and structures remains with the **CONTRACTOR**. The **CONTRACTOR** shall avoid damage to all such structures. The **CONTRACTOR** shall be responsible for all underground utilities whether or not they are located or depicted on the drawings.
- h. The **CONTRACTOR** shall be responsible for notifying pipeline, telephone, water, sewer, communications, power, and other companies or agencies who have structures above or below ground either across the construction route or near enough that there could be damaged during construction. The **CONTRACTOR** shall notify and comply with the appropriate local utility protection system or the state one-call system. The **CONTRACTOR** shall provide sufficient time in advance of construction. In addition, the **CONTRACTOR** shall provide the **COMPANY** with a record of all notifications. In the State of Vermont, the one call system is known as DIG-SAFE and can be reached at 811. Excavation tickets are valid for thirty (30) days.
- i. Utility poles in the path of construction, that require removal or relocation, shall be coordinated by the **CONTRACTOR**.
- j. **THE CONTRACTOR SHALL NOT MOVE EQUIPMENT ON OR ACROSS THE COMPANY'S EXISTINGS PIPELINE(S), EXCEPT UPON A SHOWING OF ABSOLUTE NECESSITY AND ONLY WITH THE COMPANY'S PRIOR CONSENT GIVEN IN EACH INDIVIDUAL INSTANCE AND ONLY IN ACCORDANCE WITH THE APPROVED COMPANY POLICY AND APPROVED EXISTING PIPELINE EQUIPMENT CROSSING TYPICAL DRAWING.**
- k. The **CONTRACTOR** shall have a representative on site who is experienced in landowner relations. This representative shall not be a working foreman.

- I. Prior to working on RIGHT-OF-WAY, landowners, tenants and occupants will be notified by COMPANY before start of work. CONTRACTOR shall further review entry requirements with COMPANY at least one working day preceding entry to work area.

4. CLEARING AND GRADING RIGHT-OF-WAY

- a. The **CONTRACTOR** shall clear and grade the RIGHT-OF-WAY as shown on the DRAWINGS and as approved by the **COMPANY** to facilitate the use of rubber tired vehicles and track equipment. In clearing the RIGHT-OF-WAY and in the performance of the CONSTRUCTION WORK hereunder, the **CONTRACTOR** shall comply with the terms of the CONSTRUCTION LINE LIST, all environmental and regulatory permits, environmental avoidance plans, Erosion and Sediment Control Plans, and the ENVIRONMENTAL MITIGATION PLAN, and shall carry out and perform the WORK in a manner which shall cause a minimum of inconvenience, injury, or damage to persons or property. Clearing shall include removal of all obstructions, trees, shrubs, stumps, roots, grass and other vegetation necessary to permit the installation of the proposed pipeline and pipeline facilities. Where the **CONTRACTOR** fails to observe restrictions and limitations and causes damages to property beyond the servitudes, RIGHTS-OF-WAY, permits or grants secured by the **COMPANY**, such damages shall be the **CONTRACTOR'S** liability.
- b. Prior to clearing and grading activity, the **CONTRACTOR** shall locate and mark all foreign line crossings, drain tile, underground facility and environmental/archaeological sensitive areas as directed by the **COMPANY**. The **CONTRACTOR** will expose the adjacent **COMPANY** pipeline at intervals of every 200ft and at all points of intersection, where applicable. The cost to expose the existing **COMPANY** pipeline as described will be borne by the **CONTRACTOR**.
- c. Before clearing and grading the RIGHT-OF-WAY, the **CONTRACTOR** shall move survey stakes back to the spoil side edge of the RIGHT-OF-WAY and preserve them during all phases of the WORK for use in reporting progress and locations.
- d. The **CONTRACTOR** shall take all reasonable precautions to protect, in place, public land survey monuments and private property corners or boundary markers. If any land markers or monuments, including existing company G.P.S. monuments are destroyed, the **CONTRACTOR** shall re-establish at his expense such markers or monuments in accordance with the specifications with a registered Vermont land surveyor.
- e. Material removed from the banks of streams shall not be placed in stream beds, but shall be stockpiled on the RIGHT-OF-WAY or on adjacent ATWS from where it can be recovered and used by the **CONTRACTOR** to restore the stream banks to their original state or as by directed the **COMPANY** and/or the permit requirements. Spoil shall be stored 10 feet from top banks with silt fence barrier placed between the spoil pile and the water body.
- f. Temporary bridges, roads, etc. used for construction shall be designed for proper drainage and built in such a manner to provide safe passage of construction

vehicles and to minimize soil erosion. The **CONTRACTOR** shall furnish any materials required for this purpose. Temporary bridges must span the entire water course and minimize disturbance to the bank slopes. Forging of streams is permitted with minimal clearing equipment, to allow for the installation of the stream bridges. The **COMPANY INSPECTOR** must be notified in advance of any equipment fording a stream or water body. The **COMPANY INSPECTOR** shall be on site before any equipment or vehicles are allowed to ford any stream.

- g. The **CONTRACTOR** shall install conduits, as necessary to maintain natural drainage across the RIGHT-OF-WAY. The **CONTRACTOR** shall maintain the conduits such that drainage is maintained and does not damage adjacent properties.
- h. Temporary gate shall be installed in the fences crossed by the route of the pipeline and shall be maintained through construction. The **CONTRACTOR** shall be responsible for loss of any livestock or other third party damages related to open or damaged fences.
- i. Before cutting, gates and fences shall be braced to prevent damage to them. Temporary fences shall be constructed so that they can be securely closed. Following the completion of the pipeline construction, gates and fences shall be restored to their condition prior to the beginning of construction. The **CONTRACTOR** shall furnish all such gate and fence material that equals or exceeds any existing gate and fence material. Where the pipeline crosses fields of dry grasses or crops, the **CONTRACTOR** shall provide fire watches along both sides of the RIGHT-OF-WAY at no expense to the **COMPANY**. Adequate fire-fighting equipment shall be maintained on site by the **CONTRACTOR**, for control of any brush or grass fires, resulting from burning or welding operations.
- j. The **CONTRACTOR** shall repair immediately any damage to bridges, private roads, fences, buildings, or other property when damage, in the judgment of the **COMPANY**, cannot await repair by the clean-up operation.
- k. The **CONTRACTOR** shall restore all damaged property, including but not limited to buildings, fences, hedges, roads, bridges, culverts, drainage ditches, terraces, drainage tile, creeks, levees, and rivers occupied or crossed by construction. Any property damaged during the execution of the WORK shall be restored to its original condition at the **CONTRACTOR'S** expense.
- l. All debris shall be completely disposed of in a timely manner preceding the grading operation. Cleared materials shall become Contractor's property and shall be disposed of by chipping in upland (non-wetland, non-stream, non-archaeological, non-RTE species) areas, unless otherwise directed by the **COMPANY**. Burning of debris on-site is not permitted. **In no event shall debris, stumps, tops, etc. be placed on top of the existing pipeline at any time during the project.**

- m. Stumps and trees on said RIGHT-OF-WAY shall not come in contact with the pipe. All loose stumps, brush, boulders, and other debris shall be removed so that the spoil bank from ditching operations shall not fall on any such debris.
- n. Immediately following clearing and grading operations, CONTRACTOR shall install applicable erosion prevention and sediment control measures to the right-of-way.
- o. The RIGHT-OF-WAY shall be graded in such a manner as to best facilitate the laying of the pipeline and the performance of the WORK. Grading shall be performed in such a manner as to minimize interference with existing drainage (with emphasis of adjacent wetland areas). Where terraces or drainage canals are cut, they are to be restored to their original state as soon as possible. Temporary slope breakers shall be installed and spaced in accordance the Environmental Mitigation Plan. These breakers shall be maintained for the duration of the WORK. The **CONTRACTOR** shall provide a means of natural water drainage across the construction RIGHT-OF-WAY to occur continuously during construction. Brush and other debris shall not be mixed with earth from grading and shall not be place in piles off the RIGHT-OF-WAY limits, regardless of permission of the landowner or tenant, nor placed in the trench with backfill material.

5. LOAD, HAUL, STRING

- a. The **CONTRACTOR** shall be responsible for final clean-up and restoration of the pipe yard sites located in WILLISTON AND NEW HAVEN, VERMONT and any other laydown or staging areas used for the Project.
- b. The Contractor, prior to loading of the pipe shall, along with the **COMPANY**, perform a visual inspection to verify the physical conditions of the steel and coating. Any defects so found shall be clearly marked for repair and noted on the material transfer report.
- c. The **CONTRACTOR** will be compensated for repairing steel and/or coating defects which may have occurred during transportation of the pipe from the pipe mill to the coating mill and from the coating mill to the pipe yard site in WILLISTON AND NEW HAVEN, VERMONT.
- d. Any steel or coating defect or other damage detected after the **CONTRACTOR'S** inspection shall be repaired by the **CONTRACTOR** at no additional cost to the **COMPANY**.
- e. The **COMPANY** will have a Material Clerk and the **CONTRACTOR** shall cooperate with said Clerk during the transfer of **COMPANY** materials. **COMPANY** materials shall be checked for quantity, quality, and condition by both the **COMPANY** and the **CONTRACTOR**, and transferred from the **COMPANY** to the **CONTRACTOR** by the use of a **COMPANY** supplied Material Transfer Report. Both the **CONTRACTOR** and the **COMPANY** shall sign and retain a copy of each Material Transfer Report.

- f. All side boom A-frames, lifting belts, or other binders used to handle the pipe shall be padded to protect the pipe and coating. No forklift shall be permitted to handle pipe
- g. The **CONTRACTOR** shall transport the pipe from the **COMPANY** designated Pipe Yard Facility located in WILLISTON AND NEW HAVEN, **VERMONT** to the respective work area.
- h. All pipe hauled to the RIGHT-OF-WAY shall be loaded and strung from stringing trucks w/trailers along the RIGHT-OF-WAY by boom tractors, hydraulic excavators w/vacuum lift attachment, or swing cranes. In no event shall pipe be rolled from stringing trucks. Care shall be exercised so the pipe does not lay directly on the ground. Skids with felt strips shall be placed on the ground the pipe shall be laid to rest on felt strips in a manner as to protect the integrity of the pipe and pipe coating. Offloaded pipe shall be lapped, not butted end to end.
- i. The **CONTRACTOR** or any **SUB-CONTRACTOR** that it employs to transport the pipe or other materials for the job shall secure all appropriate permits from the appropriate agency authorizing them to perform the types of transportation service required of the WORK.
- j. The **CONTRACTOR** shall secure necessary permits and licenses at its own expense for pipe transportation services as well as for the operations, hauling, and transportation of its equipment. Any damages to public roads shall be borne by the **CONTRACTOR**. Transportation services shall be performed in strict accordance with applicable federal, state, and local statutes and regulations and at the rates and in accordance with the provisions of the applicable tariff or tariffs.
- k. Felt padding strips supplied by the **CONTRACTOR** shall be placed between the skids and pipe.
- l. All pipe shall be properly chocked to prevent damage to the pipe, persons, or other property.
- m. Pipe shall not be strung ahead of excavation in rocky areas.
- n. The stringing of the pipe shall be done in such a manner as to cause the least interference with the normal use of the land crossed. Gaps shall be left at intervals as required by the **COMPANY** to permit the use of the land and the passage of livestock, equipment, and/or vehicles across the RIGHT-OF-WAY.

6. TRANSPORTATION AND STORAGE OF MATERIAL

- a. The **CONTRACTOR** shall take delivery and accept custody for all materials furnished by the **COMPANY** when and as delivered to it by the **COMPANY** at the delivery points specified. The **COMPANY** will obtain any necessary permits or approvals for the use of these delivery points.
- b. Several staging areas have been obtained by the **COMPANY** and are indicated on the Plans. Additional required staging areas shall be acquired by the **CONTRACTOR** at the **CONTRACTOR'S** expense and are subject to **COMPANY** approval. In addition, the

CONTRACTOR shall provide adequate time and sufficient information to the **COMPANY** in order for the **COMPANY**, at the **CONTRACTOR'S** expense, to provide the necessary archaeological and environmental clearances. To request **COMPANY** approval for use of any additional staging areas, the **CONTRACTOR** shall provide a written request to the **COMPANY** that will include, at a minimum the following:

- A. A map viewing the location of the space to be reviewed.
 - B. A legal description of the property.
 - C. A sketch showing dimensions and layout, and a brief description of the planned use, access road, including planned changes to the site.
 - D. Preliminary landowner approval.
- c. Should the pipe or other material be damaged by the **CONTRACTOR** or should any pipe or other material for which the **CONTRACTOR** is responsible become damaged, lost, stolen, or otherwise unaccounted for, the **CONTRACTOR** shall, at the **COMPANY'S** option and at the **CONTRACTOR'S** expense, either satisfactorily repair or replace in kind such pipe or material or shall bear the **COMPANY'S** full costs for such pipe or material delivered to the job site. If the **CONTRACTOR** does not repair, replace or reorder such pipe or material, the **COMPANY** shall withhold amounts, as determined by the **COMPANY**, equal to the **COMPANY'S** full costs for such pipe or material delivered to the job site, from payments due to the **CONTRACTOR** pursuant to the GENERAL CONDITIONS.
- d. If possible, defective pipe and pipe damaged in unloading, stockpiling, loading, hauling and stringing shall be restored to useable condition by the **CONTRACTOR** by cutting and beveling. Pipe damage for which the **CONTRACTOR** is responsible shall be repaired by the **CONTRACTOR** at no additional expense to the **COMPANY**. Pipe damage for which the **CONTRACTOR** is not responsible shall be repaired by the **CONTRACTOR** and the **CONTRACT** compensation shall be in accordance with the applicable unit price specified, in the BID SUMMARY FORM. Such repairs to damaged pipe shall be made at the direction of the **COMPANY**.

7. TRENCHING

- a. The **CONTRACTOR** shall be solely responsible for determining the existence and location of, and shall take due precautions to avoid damages to all pipelines, water mains, sewers, overhead telephone lines, underground telephone lines and cables, fiber optic cables and power conduits, high power lines, wires, poles and guy wires, railroads, highways, bridges, or other underground or above ground structures crossing or adjacent to the pipeline being constructed.
- b. The **CONTRACTOR** shall notify and comply with the appropriate local utility protection system or the state one-call system. In addition the **CONTRACTOR** shall provide the **COMPANY** with a record of all notifications.
- c. The **CONTRACTOR** shall slope and/or shore the walls of the pipeline excavation in accordance with current OSHA regulations for human occupancy of trenches.

It shall be the **CONTRACTOR'S** responsibility to determine the proper ditch bank sloping or shoring technique applicable to the type of soil excavated and to have a competent person (as defined by OSHA) present at each excavation site when occupied by a person(s).

- d. The **CONTRACTOR** will furnish a registered Vermont Professional Engineer at the **CONTRACTOR'S** expense to be available on-site for all shoring, trench box or if the depth of cut exceeds twenty feet.
- e. Trenching and excavating for the laying of pipelines shall be performed such that the pipeline, when laid, will follow the survey as staked. Ditching and excavating WORK will conform to the terms of the **COMPANY'S** permits and RIGHT-OF-WAY easements.
- f. All retrenching, re-digging and water pumping required on the pipeline trenching shall be at the expense of the **CONTRACTOR**.
- g. The bottom of the trench shall be uniformly graded in proper depths to prevent unnecessary bending of the pipe and shall be free from loose rock, snow, ice, and other objects which might cause damage to the pipe or pipe coating or prevent discovery of such damages. Tree roots shall be cut flush with the sides and the bottom of the trench to prevent damage to pipe coating. The spoil from the trench shall not be allowed to fall on any debris or other undesirable foreign matter the might become mixed with the spoil bank and be backfilled in the trench.
- h. Any corrections in the trench necessary to secure a proper fit at the bend shall be accomplished by grading the trench ahead of and behind the bend, or preparing another bend, all at the **CONTRACTOR'S** expense.
- i. Material removed from creek and river ditches shall not be placed in the stream bed or where stream flow or drainage will be obstructed. Such material will be contained in accordance the **COMPANY'S** Environmental Mitigation Plan.
- j. The depth of the pipeline cover will be a minimum of three (3) feet except where specified in the DRAWINGS. At all roads streams and ditches, the depth of cover shall be a minimum of five (5) feet unless the required pipeline cover is noted otherwise. The depth of pipeline cover in agricultural lands and VELCO right-of-ways shall be a minimum of four (4) feet unless the required cover is noted otherwise. If concrete coated pipe is used, depth of cover will be measured from the top of concrete to natural grade. The **CONTRACTOR'S** Bid Price for extra depth ditch is applicable to only those areas where extra depth is required in addition to that provided for herein. All excavation/cuts at streams, roads, and ditches are to comply with any **COMPANY**, local, state, or federal permit requirements, and will be done so at no additional expense to **COMPANY**.
- k. The pipe shall be laid in the original soil and not in any new embankment established by the **CONTRACTOR'S** grading operations.

- l. In the event of damage to foreign facilities, the **CONTRACTOR** will promptly notify the **COMPANY**. The **CONTRACTOR** will be responsible for all repairs and expenses associated with such damage.
- m. To facilitate construction such as finding suitable subsoil conditions, the **CONTRACTOR** may excavate trenches to a greater depth than the minimum requirements given herein. No additional compensation will be paid to the **CONTRACTOR** for the additional excavation if intended for **CONTRACTOR'S** convenience. Spoil banks from any ditching operations shall not be placed where drainage will be affected and such spoil banks will be placed in a manner acceptable to the property owners and/or requirements as may be prescribed by federal, state, county or other agencies having jurisdiction.
- n. The **CONTRACTOR** shall separate, store, and replace top soil for the RIGHT-OF-WAY as specified in the Bid Documents and Drawings. All top soil shall be backfilled as a separate operation and shall be replaced over the grade from which it was removed in a manner satisfactory to the **COMPANY**. Any top soil required to restore the pre-construction top soil conditions will be at the **CONTRACTOR'S** expense for those areas initially top soiled. The **CONTRACTOR** shall obtain **COMPANY** approval for sourcing top soil material.
- o. During construction, **CONTRACTOR** shall not maintain more length of open trench than is necessary for the daily rate of lowering-in of pipe. When reasonably required by landowner or tenant to have passageway across the trench, the **CONTRACTOR** shall provide, at the **CONTRACTOR'S** expense trench soft plugs for crossing the trench at locations required by the landowner or tenant.
- p. Certain RIGHT-OF-WAY Agreements or permits may require that extra depth trench be provided at certain locations. The **CONTRACTOR** shall provide such extra depth trench as required in the CONSTRUCTION LINE LIST. The **CONTRACTOR** will be paid no additional compensation for the extra depth trench required by the CONSTRUCTION LINE LIST, provided this information contained in the CONSTRUCTION LINE LIST was available at the time of bidding.
- q. High water table conditions may require the use of pumps, well points, or other means of dewatering. The **CONTRACTOR** shall comply with all conditions of the pit/trench dewatering permits obtained by the **COMPANY**. In general water should be discharged through filter bags to upland areas with care taken to avoid discharging into surface waters or crop land. No additional compensation shall be due to the **CONTRACTOR** for any dewatering devices. The **CONTRACTOR** shall bear the costs for damages resulting disposal of such water from the trench upon any properties in proximity to the RIGHT-OF-WAY.
- r. Unless noted otherwise the **CONTRACTOR** shall provide the required trench to allow installation of the pipe below an existing facility with a minimum vertical clearance of not less than twelve (12) inches. Drainage tile shall have the minimum

vertical clearance of twelve (12) inches between the tile bottom when restored to its normal position and the top of the pipe when placed in the trench.

- s. Where existing underground drain tile are encountered, the trench shall provide for the installation of the pipeline under the tile. Any existing drain tile damaged, cut, or removed shall be immediately repaired as necessary to allow for its proper function until the tile can be permanently repaired. The **CONTRACTOR** shall place a lath, with red flagging attached, in the trench spoil bank directly opposite any damaged or removed tile. The marker shall not be disturbed until the tile has been repaired and the repairs have been approved and accepted by the **COMPANY**. Permanent repair and replacement of drain tile shall be done in accordance with the SPECIFICATIONS and the DRAWINGS.
- t. ATWS has been acquired at certain road crossing, stream, and highway crossings to provide extra storage space for the excess spoil material resulting from the excavations. In agricultural land, the additional area used at each crossing shall be stripped of top soil prior to the placement of any spoil in the area, unless otherwise noted by the **COMPANY**INSPECTOR. Top soil shall not be used to ramp culverts, ditches, or drains.
- u. Roadways shall not be blocked without approval of Town or County authorities concerned. Adequate protection of road users from **CONTRACTOR**'s excavations shall be provided by means of barricades, lanterns and warning signs, and the provision of detours and flagmen.
- v. Soft plugs shall be installed at start and end of wetland if trench has potential to drain wetland.
- w. Trench shall have graded slopes for egress of wildlife.
- x. The **COMPANY** shall expose, mark with a red flag, and subsequently backfill the **COMPANY'S** existing adjacent pipeline at intervals of not more than 200ft, at all points of intersection and at any other locations deemed necessary by the **COMPANY**. The **CONTRACTOR** shall be provided with a daily pot hole log from the **COMPANY** which shall identify the location (station number) and depth of the existing **COMPANY** pipeline.
- y. The new pipeline may be laid adjacent to the existing **COMPANY** line. In all areas, it shall be the **CONTRACTOR'S** responsibility to stabilize the existing line adjacent to the pipeline trench by methods approved by the **COMPANY**. The approval shall be obtained prior to trenching. Failure to stabilize the existing line may cause damage to the existing line. If damage occurs to the existing line due to unstable conditions, all costs for repair and clean-up shall be borne by the **CONTRACTOR. THIS IS A SINGLE LINE FEEDING INTO THE GREATER BURLINGTON, VERMONT AREA. A LINE BREAK WILL PLACE 40,000 CUSTOMERS AT RISK OF LOSING GAS SERVICE.**

- z. Refer to the following Specifications for additional requirements:
 - A. 312319 Dewatering
 - B. 312333 Trenching and Backfill
 - C. 315000 Excavation Support and Protection

8. **BENDING AND LAYING PIPE**

- a. The **CONTRACTOR** shall make all necessary field pipe bends required in the construction of the line. The **COMPANY** may, at its option provide fabricated segmentable el's at locations where the use of such segmentable el's is deemed preferable. The **CONTRACTOR** shall be responsible for determining the degree of field bend necessary at points of angularity in the pipeline to allow the proper lay of the pipe in the ditch.
- b. All bending shall be done by the cold smooth method using a bending machine approved by the **COMPANY**. No fire or wrinkle bends will be allowed. Welded longitudinal pipe seams shall be right angles (neutral axis) to direction of bends, when applicable. The **CONTRACTOR** shall furnish and use, at no additional expense to the **COMPANY**, an internal bending mandrel to achieve smooth and undistorted bends, if necessary. Padded bending shoes are required for coated pipe. In no case shall heat be applied to the pipe for bending purposes.
- c. For field cold bends the longitudinal axis shall not be deflected more than 1-1/2 degrees in any length along the pipe access equal to the diameter of the pipe. An accurate method of measurement shall be used. The maximum diametrical reduction in a pipe bend shall not exceed 2-1/2% of the nominal pipe diameter. There shall be no deviation from the above constraints without prior written **COMPANY** approval. Separate approval must be obtained for each incidence.
- d. The distance between centerline of bending points shall be such that there will be no distortion of the pipe or of the bend previously made and in no event shall be closer than seven (7) feet to the end of the joint of the pipe. When pipe is double jointed before bending, the bend shall not be closer than three (3) feet to the butt (girth) weld.
- e. The pipe bends shall be measured, laid out, bent, and welded so that the complete pipeline will be in compression. All over-bends, sag bends and side bends shall be made and installed in such a manner that an adequate amount of slack is provided in the line. All over bends shall be made in such a manner that the mid-point of the bend when installed shall clear the high point of the trench bottom by a minimum of four (4) inches. Side bends shall have the neck against the outside curve of the ditch. All sag bends shall be fitted snug to the bottom of the ditch.
- f. If the **COMPANY** so directs, and prior to the bending of any pipe to be used on the WORK, test specimens of any or all sizes of pipe to be used on the WORK shall be bent to determine the optimum bending and the distortional limitations

that will be used on the WORK. For such test the **CONTRACTOR** shall furnish the labor and equipment necessary and the **COMPANY** shall furnish the pipe.

- g. Under no circumstances shall any bend be straightened.
- h. Any pipe that is buckled, wrinkled, flattened, egged or gouged by the bending operations shall be cut out and replaced at the sole expense of the **CONTRACTOR**. Hammering or the use of jacks at any time to attempt to repair buckled or deformed pipe is prohibited. A buckle shall be defined as any anomaly in the contour of a bend which, when measured with a six (6) inch metal straight edge oriented on the longitudinal axis, yields a depression or valley beneath the straight edge in excess of .06 inch.
- i. For pipe line-up, the pipe shall be placed on skids with sufficient clearance between the bottom of the pipe and ground to accommodate the finishing weld. Pipe shall be handled in a manner to prevent damage to the pipe walls and shall be placed over or parallel to the ditch in such manner that when the pipe is lowered, the bends will rest in the ditch at the proper location. The **CONTRACTOR** shall align pipe so as to provide adequate slack when lowered. In the laying of the pipe other than seamless pipe, the longitudinal seams shall be offset by 20 degrees on adjoining pipes in the top 120 degrees of the pipe and welded sections shall be assembled and lowered into the trench so that the longitudinal seams will remain on the top 120 degrees of the pipe as laid. Exceptions shall be weld seams on side bends, which shall be located on top of the pipe, and weld seams on sag bends and over bends, which shall be located on either side of the pipe as laid.
- j. At temperatures of 0°F or below, COMPANY shall supply a pipe joint to CONTRACTOR for bend tests. Pipe shall be bent to the required curvature or to a less severe limit, should buckling, wrinkling or flattening occur. A restriction on bending shall be set by COMPANY which shall be subject to a re-test should the ambient temperature drop a further 10°F.

9. WELDING

- a. All welding shall meet the requirements of the latest approved edition of API 1104 Welding of Pipelines and Related Facilities, as approved by the Department of Transportation Title 49 CFR, Part 192, Transportation of Natural Gas and Other Gas by Pipeline.
- b. The **COMPANY** shall provide approved qualified Welding Procedures to be used to complete the WORK.
- c. All welders to be used on the WORK must pass a destructive butt qualifying test and branch qualifying test as prescribed by API 1104, under the **COMPANY'S** supervision and subject to the **COMPANY'S** approval. For making such test, the COMPANY will supply the pipe and the CONTRACTOR shall supply all equipment

and supplies, including testing machines and jigs, and labor of the welders being qualified. The tensile testing machine shall be calibrated by an independent laboratory prior to use, and the **CONTRACTOR** shall present the certificate of calibration to the **COMPANY** prior to its use. The **CONTRACTOR** shall notify the **COMPANY** of the time and location of the welder qualifications tests; whereupon, the **COMPANY** will witness the welding WORK and subsequent testing. In the event that either the **COMPANY** or the **CONTRACTOR** are not satisfied with a Welder's Test results, the welder shall not be employed. No extra test coupons shall be allowed. The **COMPANY** shall promptly notify the **CONTRACTOR** as to the qualification or disqualification of each welder tested.

- d. After each welder has been accepted as qualified, he shall be permitted to weld on production lines subject to COMPANY's privilege to cut an additional test weld from the line. For all pipe diameters the test weld shall be radiographed and then followed by a Mechanical Test Procedure meeting the requirements of API 1104. Defective welds will follow criteria of API 1104 to determine acceptability. Where defective welding involves two or more welders, COMPANY and CONTRACTOR's welding foreman shall devise further tests and determine which welder is at fault.
- e. The **CONTRACTOR** shall take every precaution to produce welds that meet the requirements of these SPECIFICATIONS by the initial welding process. Should the number of welds failing to meet these SPECIFICATIONS exceed SEVEN (7) percent based on total production for one full working day, the **COMPANY** reserves the right to suspend welding operations until the problem is identified and corrective measures are submitted for the **COMPANY'S** approval. Upon resuming welding operations, the **CONTRACTOR** shall produce a Controlled Welding Section of twenty welds, having opening at each end, which the **COMPANY** will promptly inspect. During the period the Controlled Welding Section is being inspected, the **CONTRACTOR** may only continue welding operations with the **COMPANY'S** approval. Should the results of the Inspection of the Controlled Welding Section be unacceptable, the **CONTRACTOR** shall suspend welding operations. Instructions will then be issued by the **COMPANY** regarding further welding operations.
- f. All costs associated with unsatisfactory welding shall be at the **CONTRACTOR'S** expense.
- g. All welds shall be radiographically inspected at the **COMPANY'S** expense according to API 1104. If the results of these inspections indicate the welds to be defective, **CONTRACTOR** shall replace or repair the defective welds at **CONTRACTOR'S** expense. If the cut-out method of examination of weld is employed by the **COMPANY**, the **COMPANY** may, in the judgment of its **COMPANY INSPECTOR**, cut-out and test any welds designated by him. Should such cut-out welds pass the requirements of API 1104, the cost of cutting out

and subsequent tie-in will be borne by the **COMPANY**. The cost of cutting out and replacing any welds that fail the tests shall be borne by the **CONTRACTOR**.

- h. **CONTRACTOR** shall use the shielded metal-arc welding (SMAW) process on all mainline welds (sometimes called “stick electrode welding” or “shield arc process”). Welding will be performed in the vertical downhill direction, except for hot taps. Electrode stubs shall be collected at the time of use, accumulated for disposal, and may not be left on the RIGHT-OF-WAY, in the trench, or in the backfill.
- i. The general requirements of mainline welding shall also apply to the welding of pipeline components such as valves, fittings, flanges, crossovers, tie-ins etc.
- j. Each beveled end of a joint of pipe shall be cleaned in a manner satisfactory to the **COMPANY** to remove dirt, mill scale, and other foreign substances before being placed in alignment for welding.
- k. The adjoining lengths of pipe shall be accurately aligned by the use of a suitable alignment clamp of a type and manufacture satisfactory to **COMPANY**. The adjoining lengths of pipe shall be aligned and spaced to provide a root face opening per the qualified Welding Procedure Specification (WPS). All bevels shall be 30 degrees, +5 degrees, -0 degrees. All root face (lands) shall be 1/16 inch, +1/64 inch, -0. Pipe possessing a longitudinal weld joint shall have all seams positioned in the top 120 degrees with the exception of over bends and sags. Weld seams of adjoining pipe shall be staggered a minimum of 30 degrees.
- l. The root bead (stringer bead) shall be applied completely around the pipe followed immediately by a thorough cleaning of all scale, coating, slag, etc. The first bead or “stringer” shall be completed prior to the application of subsequent beads. The second bead (hot pass) shall be started immediately after completion of the stringer within the time limits indicated on the Welding Procedure Specification (WPS). The hot pass shall fully fuse the pipe bevel at each side of the stringer, making the deposit a minimum of one-third the pipe wall thickness. On pipe 16” OD and larger the stringer and hot pass shall each require two or more welders working on opposite sides to equalize stress.
- m. No tack welds shall be permitted except when using external line up clamps on tie-ins, transitions, and fabrication piping and then only when preheating requirements are met.
- n. The start of all weld passes shall overlap and no pass shall start closer than two (2) inches from the start of the preceding pass.
- o. Internal alignment clamps shall not be relaxed until 100 percent of the root bead has been completed. External alignment clamps shall not be removed until at least 50 percent of the root bead has been completed provided that the completed portion of the root bead is in approximately equal segments evenly distributed about the circumference of the joint. Skids shall be placed in a manner to prevent stress on completed root beads.

- p. When welding concrete coated pipe, internal alignment clamps shall not be relaxed until both the root bead and hot pass have been completed.
- q. The “Stringer Bead” and “Hot Pass” welding operation shall not be advanced ahead of the finished welding operations to the extent that the section of line containing unfinished welds would be likely to fall from skids because of contraction and/or expansion of the line due to change in temperature. When the pipe is laid on skids after welding it shall be blocked and secured from rolling off skids in a manner acceptable to the **COMPANY**. The placing of skids shall be close enough to prevent undue stress on the free spanning pipe. Should a section of the line containing unfinished welds fall from the skids, the **CONTRACTOR’S** representative shall immediately report the same to the **COMPANY** and all cost of any inspection and/or repairs shall be borne by the **CONTRACTOR**.
- r. A preheat shall be used at all times. Preheat shall cover a band (4) inches wide on each side of the proposed weld. Heating shall not char the pipe coating. The temperature will be measured by temperature measuring crayons an infrared temperature detector, or other acceptable tools to be furnished by the **CONTRACTOR**. This process shall be performed immediately prior to welding.
- s. The **CONTRACTOR** will take necessary precautions to insure that no arcing occurs between the ground bevels, leads of the welding machines and the pipe. Striking the arc on the pipe at any point other than the welding groove shall not be permitted. All arc burns occurring outside the welding groove shall be removed from the pipeline by cutting out a cylinder of pipe containing the arc burn or arc burns and replacing it with new pipe at the **CONTRACTOR’S** sole expense. Said cylinders are the property of the **COMPANY** and shall not be destroyed or tested on by the **CONTRACTOR**.
- t. The open ends of all sections of line pipe shall be securely closed with suitable “Night Caps” supplied by the **CONTRACTOR** at the end of each day’s WORK to prevent the entrance of small animals, water and obstructions. The pipe ends shall not be reopened until the WORK recommences. Covers shall be canvas type with an air release hole and tie cord (or secured with duct tape). Any obstructions in the line shall be removed by the **CONTRACTOR** at is expense and to the satisfaction and approval of the **COMPANY**. The line must be delivered free, from water, dirt, obstructions, and other foreign substances.
- u. The **CONTRACTOR** shall promptly collect, re-bevel, clean, haul ahead and place in the pipeline all usable “pup” joints having a minimum length of five (5) feet. “Pup” joints must be separated by a full-length joint. The **CONTRACTOR** shall be responsible for transferring all of the pipe stencil information to all pup joints.
- v. The **CONTRACTOR** shall be required to re-bevel and weld all surplus pipe that is five (5) feet or more in length into nominal forty (40) foot lengths of pipe upon job completion at the **CONTRACTOR’S** expense.

- w. A mechanical transition machine shall be used to taper bore pipe transitions for adjoining pipe wall thickness differences that exceed 0.94 inch. Flame cutting or hand grinding internal transition bevels shall not be permitted, with the exception of test head fabrication.
- x. Each welder shall identify that portion of the weld performed by him on an area adjacent to the weld and in the top quarter of the pipe. A number will be assigned to each welder by the **COMPANY** while conducting his qualification test. Numbers shall be marked with a **COMPANY** approved material. Die stamping will not be used. In the event any welder leaves the job, his number shall not be used by another welder.
- y. In the case of inclement weather, the **CONTRACTOR** shall provide protection for the welders at their WORK and care shall be taken to see that no welds are subjected to moisture or sudden variations in temperature. No welded sections of pipe shall be rolled off skids or dollies until the welds are thoroughly cool. The **CONTRACTOR** shall provide artificial lighting when necessary at no additional cost to the **COMPANY**.
- z. Splatter shields shall be utilized during the welding operations to protect the adjacent pipe coating.
- aa. During the final tie-in section the pipe shall be supported by side booms until all filler passes are complete.

10. GIRTH WELD REPAIR PROCEDURE

- a. If NDT inspection indicates a weld to be defective, the **CONTRACTOR**, at no additional cost to the **COMPANY**, shall cut a cylinder of pipe containing such weld from the pipeline and replace it with new pipe or shall have the defective weld repaired in accordance with API 1104. Correction of an individual bead prior to the laying of a succeeding bead is not considered a repair of a defect under these SPECIFICATIONS.
- b. Preheating shall be used for all repair welding. Such preheating shall be accomplished by a method acceptable to the **COMPANY** and shall cover at least four (4) inches wide on each side of the weld. Heating shall not char the pipe coating. Preheat temperature shall be checked by use of temperature indicating crayons or an infrared temperature detector.
- c. All repair and replacement welds shall be NDT inspected and shall meet the acceptance standards of API 1104.
- d. The **COMPANY** will allow repair of welds subject to the provisions of API 1104.
- e. Only one repair shall be allowed per girth weld. The necessity of a second weld repair constitutes a mandatory cut-out.
- f. The accumulated length of weld repairs shall not exceed 8% of the total length of the girth weld.
- g. Under no circumstances should attempts be made to repair cracks in a weld. All cracks shall be cut outs.

- h. When welding the line pipe together at places where cut-outs have been made, one replacement weld will be used if it is practical to pull the line back into position; otherwise, two welds will be made by fitting in a “pup joint”, which shall have a length of not less than five (5) feet.

11. COATING PIPE JOINTS AND UNDERGROUND FITTINGS

- a. The steel pipe being supplied by the **COMPANY** shall be Pritec 10/40 as indicated in the SPECIFICATIONS with all coating material and coating equipment supplied by the **CONTRACTOR**.
- b. The **CONTRACTOR** shall be responsible for the storage and application of all field-coating materials in accordance with the manufacturer’s specifications.
- c. All field joints shall be coated with COMPANY approved shrink sleeves on Pritec coated pipe and SP2888 on ARO coated pipe. Any bare below ground pipe shall be coated using SP 2888 two part epoxy coating. All coating material and coating equipment shall be supplied by the **CONTRACTOR**. Coating will be applied having a dry film thickness of at least 20 mils. Holidays in the epoxy pipe coating shall be repaired using SP 2888 two part patch mix and shall be furnished by the **CONTRACTOR**.
- d. Any field joints or pipe with inadequate or excessive film thickness, uncured coating or disbonded/non-adherent coating shall be completely re-blasted to base pipe and recoated by the **CONTRACTOR** at no additional cost to the **COMPANY**.
- e. The **CONTRACTOR** shall provide a representative from the field coating vendor to conduct coating product field application training. All **CONTRACTOR PERSONNEL** and **COMPANY INSPECTOR’S** responsible for applying the field joint coating and inspection over the installation and application of the field coating and **CONTRACTOR PERSONNEL AND COMPANY INSPECTOR’S** responsible for repairing the coating holidays shall attend the coating product field application training. All below grade fabrication bare pipe, fittings, and valves will be coated by the **CONTRACTOR** with all materials supplied by the **CONTRACTOR**.
- f. Prior to coating, all oil, grease or other deleterious matter shall be removed prior to blast cleaning. All exterior surfaces of below grade pipe to be coated shall be blast cleaned to SSPC-SP10 at a minimum to the coating manufacturer’s specifications for required cleanliness and profile before any coating is applied. The **CONTRACTOR** shall ensure that existing pipe coating and field joint coating are properly applied and bonded per the manufacturer recommendation. The **CONTRACTOR** shall furnish all materials and paint the above grade pipe, fittings, and equipment that have not previously been painted or that have been primed and require a flash coat.
- g. The field coating system shall be compatible with existing coating. The **CONTRACTOR** is required to obtain **COMPANY** approval of the selected coating.

DRAFT NOT FOR CONSTRUCTION

The **COMPANY** shall provide the **CONTRACTOR** with the **VERMONT GAS SERVICES COATING SPECIFICATIONS**.

- h. All coating shall be done in accordance with Manufacturers recommendations and the **COMPANY'S** approval.
- i. Coating thickness shall be monitored by use of an appropriate dry film thickness gauge.
- j. Holiday inspection shall be performed on all pipe and fittings with an electronic holiday detector, supplied by the **CONTRACTOR**, and operated in such a manner as to audibly and visually detect the presence of all holidays. Said inspection shall be performed as outlined in NACE Standards RP 0303-2003, RP0274, SP0490, latest revisions, with a certified holiday detector. This inspection shall occur on all piping to be buried..
- k. If a jeep voltage is not specified by the manufacturer then the holiday detection voltage shall be determined by $V = 125 \times T$, Where T = coating film thickness in mils. Proper voltage settings shall be confirmed by detecting three artificial holidays place in the initial joint.
- l. For fabrication inspection, the electrode shall be a wet sponge detector supplied by the **CONTRACTOR**.
- m. For pipe inspection, the electrode shall be the pipe OD and consist of a rolling spring composed of square stainless steel wire. The spring length shall fit securely to the surface of the pipe.
- n. The holiday detector manufacturers approved by the **COMPANY** are:
 - A. D.E. Stearns Company
 - B. SPY Holiday Detectors
 - C. Tinker & Rasor
- o. **CONTRACTOR** may submit alternate equipment for approval by the **COMPANY**.
- p. The **CONTRACTOR** shall be responsible for all damages to pipe or pipe coating outlined in these SPECIFICATIONS. The **CONTRACTOR** shall repair coating damage and piping damage at no additional cost to the **COMPANY**.
- q. Any joints of pipe with a limited number of holidays shall be repaired using **COMPANY** approved material for areas in excess of two square inches; hot melt epoxy patch stick for areas two square inches and less shall be applied as recommended by material vendor. Epoxy patch sticks shall not be used on any pipe to be installed by boring.
- r. Upon completion of the pipeline construction final clean up, the **COMPANY** may elect to conduct a DCVG Coating Survey. The **CONTRACTOR** shall uncover all of the holidays detected. The coating shall be cleaned, dried, jeeped, and the uncovered coating defects shall be repaired. Any Coating Integrity indications uncovered that require coating repair will be at the **CONTRACTOR'S** expense, including the excavation, coating repair, backfill and final clean up. Should the

COMPANY elect to perform a DCVG Survey the cost to perform the DCVG Survey will be borne by the **COMPANY**.

12. LOWERING IN

- a. Debris, skids, rocks, large clods, welding rods, projecting rocks and other foreign objects shall be removed from the bottom of the trench prior to lowering in the pipe so that the protective coating is not damaged. Top soil shall not be used for padding materials. All bedding and padding materials shall be one and one-half (1 1/2) inch and smaller in size.
- b. TUFF N NUFF Rock Shield, furnished by the **CONTRACTOR**, will be used in locations to protect the pipe and pipe coating from loose rocks in the backfill. Rock shield will be "TUFF N NUFF" three eighths 3/8 inches thick and shall be installed around the circumference of the pipe. Both bedding/padding materials and rock shield shall be utilized to protect pipe and pipe coating from loose rocks in the backfill.
- c. The **CONTRACTOR** shall remove water and snow from the bottom of the trench before lowering pipe into the trench. The **CONTRACTOR** shall meet all conditions as listed on the **COMPANY** acquired pit/trench dewatering permit.
- d. Immediately prior to and during lowering in, the **CONTRACTOR** shall check the coating with an electrical holiday inspection instrument supplied by the **CONTRACTOR** and approved by the **COMPANY**. All pipe shall be inspected for holidays and all holidays shall be repaired in accordance with these SPECIFICATIONS.
- e. Jeeping shall be done before any rock shield, pipe saks, concrete coating or any other type of additional materials are applied to the pipe.
- f. Final jeeping shall be done when pipe is lifted into the ditch. At no time shall the pipe be jeeped or lowered in without a COMPANY INSPECTOR present.
- g. The **CONTRACTOR** shall be responsible for all equipment to be in good working condition. The **CONTRACTOR** shall have on the job at all times a holiday detector calibrator to make sure the proper setting is obtained. The **COMPANY** will have the right to inspect or test equipment to determine if it is in proper working condition.
- h. Holiday detectors shall have adequate grounding at all times.
- i. During lowering operations, coated pipe shall be handled by use of adequately spaced lowering in belts or cradles. Belts shall be at a minimum equal to the diameter of the pipe width and made of proper material, which shall be free of protrusions that may cause damage to the protective coating. Roller cradles shall have nylon/neoprene roller wheels.
- j. The coated pipe shall be lowered into the trench in a manner that will allow proportionate distribution of the total weight of pipe to prevent undue stress or strain on the pipe and to prevent damage to the pipe coating. The pipe shall not be dropped or subjected to jarring or impact.

- k. Sections of coated pipe being tied into the line shall not be dragged or pulled into position. The length of sections shall be regulated to allow handling without damaging the protective coating. At water crossings or at any other locations where it may be necessary to pull or drag sections of pipe into place, the coated pipe shall be properly protected using wood lagging provided by the **CONTRACTOR** and handled in a manner to prevent damage to the coating or to the pipe.
- l. On hillsides and sloping ground, unfrozen rock-free earth filled bags shall be placed in the bottom of the trench before the pipeline is lowered in position. Before backfilling the ditch, additional bags shall be placed on and around the pipe to form a trench breaker. The trench breaker shall be built slightly lower than the surface of the ground to prevent water flow in the bottom of the backfill ditch. The location of the trench breakers shall be as shown on the Drawings and as required by the **COMPANY**.
- m. When lowering the pipe the unsupported length of straight pipe or pipe containing sag or over bends shall not exceed 150ft. All side bends shall be supported to minimize torsional stress in the pipe.

13. **BACKFILLING**

- a. At no time shall the trench be backfilled without the **COMPANY INSPECTOR** present. Prior to backfilling trench it is the responsibility of the **CONTRACTOR** to obtain approval from the **COMPANY**. If any section is backfilled without the **COMPANY'S** approval and the **COMPANY** so requests, the **CONTRACTOR** shall uncover the pipe for inspection at no additional expense to the **COMPANY**.
- b. Backfilling operations shall commence as soon as possible after the pipe has been lowered into the trench. The amount of lowered pipe not backfilled shall remain minimal at all times. Backfilling of all side bends, over-bends and sag bends shall be performed within the same workday as lowering in unless approved otherwise by the **COMPANY**. The **CONTRACTOR** shall take all necessary precautions to ensure that backfill material is kept free of all stones, rocks, skids, stumps, brush, welding rods, cans, bottles, trash and other debris. During frost conditions, the **CONTRACTOR** shall backfill with the utmost care. After bedding and padding of the pipe in frost conditions the **CONTRACTOR** will sift for smaller backfill material prior to backfilling with larger frozen clumps.
- c. If backfilling or any other operation damages replaced or existing drain tile, the **CONTRACTOR** shall excavate and repair the damaged tile immediately at no additional cost to the **COMPANY**.
- d. If subsurface water is encountered, **CONTRACTOR** shall implement draining techniques to channel the water from the ditch at the **CONTRACTOR'S** expense and in accordance with applicable permits.
- e. All disturbed areas shall be restored to its original condition, or better, per the Army Corps of Engineers Permit, Vermont Wetland Permit, Individual (NPDES) Construction

Stormwater Permit, Vermont 401 Water Quality Permit, Construction Line List, and landowner clean up and final restoration sign off agreement, applicable procedures and the requirements of the Land Owners Line List. This shall include backfilling the pipe trench and restoring creek banks, hillsides, or other locations that are disturbed. Backfilling of the trench shall be executed with extreme care so as not to damage pipe or coating. Hand labor shall be used during initial backfilling as deemed necessary by the **COMPANY**.

- f. At all locations where the pipeline crosses roadways, walkways, and proposed roadways where the open trench method of crossing is utilized, backfill shall be placed in lifts and mechanically compacted within the limits of the existing or proposed pavements and to the satisfaction of the governing agency. The **CONTRACTOR** shall hold the **COMPANY** harmless from any and all damages resulting from open trench Construction. Unless specified otherwise, backfill compaction shall achieve at least ninety five percent (95%) Modified Proctor density by wetting and tamping at all levels in the backfill material. Approval shall be received from the **COMPANY** to operate compaction equipment within thirty-six (36) inches of the pipeline.
- g. Attention shall be given in backfilling the pipeline near roads to ensure that proper pad dirt is place in such a manner as to completely fill the voids around and under the pipe and to prevent damage to electrolysis test site leads.
- h. The **CONTRACTOR** shall compact, subject to **COMPANY** approval, ditches crossing residential and industrial yards and bell holes around all above ground pipeline appurtenances at the **CONTRACTOR'S** expense.
- i. The pipe shall rest on undisturbed trench bottom provided the material does not include rocks, sharp objects and/or debris that may cause damage to the pipe. Structured pipe pillows shall be installed in the bottom of the trench at maximum intervals of every 16ft to protect the pipe from lying on rocks, sharp objects and/or debris which may cause damage to the pipe or pipeline coating. The **COMPANY** may require the **CONTRACTOR** to use select fill trench bottom padding material. Select fill base material for rock trench areas and areas with cobbles/boulders, shall provide a minimum of nine (9) inches of padding below and twelve (12) inches of padding on the sides and top of the pipe. Select fill material and/or padding material shall be sand in accordance with VTrans Standard Specification 703.03 or shall be screened native material containing silts, sands and gravels with the largest material being no larger than 1-inch on the longest dimension. Topsoil from the **RIGHT-OF-WAY** shall not be used for padding material.
- j. The **CONTRACTOR** shall build temporary slope breakers to divert the flow of water from grades on the **RIGHT-OF-WAY** onto areas protected by established vegetation. See Environmental Mitigation Plan.
- k. Through agricultural and pasture lands, rock three (3) inches and larger measure in any dimension shall be removed as stated in the Environmental Mitigation Plan and the Agricultural Mitigation Plan or Agreement. Rock 12 inches and

larger shall not be allowed in any portion of the backfill, unless otherwise stated in the CONSTRUCTION LINE LIST.

- l. Surplus rock shall be disposed of at the **CONTRACTOR'S** expense as follows:
- m. If the landowner and/or tenant requests that the surplus rock be removed from his property and the **COMPANY** agrees, the **CONTRACTOR**, at his expense, shall haul the surplus rock by the shortest route to a dumping ground approved by the **COMPANY**. The **CONTRACTOR** shall submit to the **COMPANY** a list of possible dumping grounds together with such documentary evidence of approval by the Public or Private Authority having jurisdiction or control over the dumping grounds, for **COMPANY** approval for the use of such grounds.
- n. If approved by the **COMPANY** and landowner, the rock shall be buried at a sufficient depth on the RIGHT-OF-WAY at the **CONTRACTOR'S** expense.
- o. Depending on soil conditions a crown shall be place over the backfilled ditch line, unless no crown is requested by the **COMPANY** or landowner. See the Agricultural Mitigation Plan or Agreement for further detail. Under no circumstances shall a crown be left in wetlands, ditches, drains or streams.
- p. Particular care shall be exercised in order that all drainage ditches be maintained and left unobstructed to prevent the back up of water against the spoil bank of backfill.
- q. At tie-ins to existing pipe, special attention shall be given to ensure that padding dirt is placed in such a manner as to completely fill all voids around and under the pipe.
- r. If the subsoil is not suitable for backfill and compaction, the **CONTRACTOR** shall provide select fill material, backfill and compact as specified in the BID DOCUMENTS. No additional compensation will be paid to the **CONTRACTOR** for any compaction required. All excess or non-usable material shall be hauled off the RIGHT-OF-WAY at the **CONTRACTOR'S** expense.
- s. The **CONTRACTOR** is responsible for all ditch line settlement until the warranty period expires. Should the ditch backfill material settle within the warranty period, the **CONTRACTOR** shall return and make repairs at no additional cost to the **COMPANY**. In Agricultural areas, imported topsoil may be required from **COMPANY** approved sources to repair ditch line settlement.
- t. Refer to the following Specifications for additional requirements:
 - A. 312333 Trenching and Backfilling
 - B. 310519.13 Geotextiles for Earthwork

14. APPURTENANCES

- a. Appurtenances included under this SPECIFICATION are: fabricated assemblies (mainline valves, station facilities, crossovers and crossunders, pipeline markers, aerial markers and electrolysis stations.)

- b. Material handling, trenching, bending, hydrostatic testing and all other WORK required to fabricate and install Appurtenances shall be in accordance with the applicable sections of the SPECIFICATIONS.
- c. Other contractors (station, grading, electrical, building erection, etc.) may be constructing and installing facilities within the same sites and RIGHTS OF WAY as this WORK. All personnel shall be compatible to working on the same site with another contractor's personnel and subcontractors. Construction shall be carried out in such a manner as to provide a minimum of inconvenience to all concerned.

15. FABRICATED ASSEMBLIES

- a. The **CONTRACTOR** shall fabricate and install complete mainline crossunder/crossover assemblies as shown on the DRAWINGS.
- b. At flanged connections, bolts shall be tightened evenly by means of an impact wrench to impose equal pressure on the gasket at all times per **COMPANY** procedure and industry bolt torque standards. In bolting up flanges, an approved thread lubricant shall be used on all bolt threads and flange faces. Ordinary greases shall not be used for this purpose.

16. ELECTROLYSIS TEST LEADS

- a. The **CONTRACTOR** shall install electrolysis test leads at the location identified on the DRAWINGS. The type of test lead and the method of installation (thermite weld process) shall be in accordance with the DRAWINGS.
- b. The **COMPANY** will check all test leads for electrical continuity after backfilling and those found broken or otherwise defective shall be excavated and re-installed or repaired at the **CONTRACTOR'S** expense. All cables shall be continuous with no splices.
- c. No test leads shall be installed on foreign lines by the **CONTRACTOR**. The **COMPANY** will install all test leads on foreign lines to comply with all specifications of foreign pipeline companies and DRAWINGS.

17. PIPELINE MARKERS

- a. The **CONTRACTOR** shall install markers on both sides of roads, railroads, or stream crossings, fence lines, where existing markers are installed or any other locations as directed by the **COMPANY**.
- b. All pipeline markers shall be furnished by the **COMPANY** and installed by the **CONTRACTOR**.

18. TILE REPAIR

- a. A tile crossing shall be defined as any portion of tile traversing or adjacent to the RIGHT-OF-WAY that is disturbed by Construction activities.
- b. All tile disturbed by the **CONTRACTOR'S** equipment shall be excavated for inspection and temporarily repaired in accordance with the DRAWINGS and the Landowner Agreement. Tile damaged during trench excavation shall be

immediately reported to the **COMPANY**. The **CONTRACTOR** will mark such locations by survey station on a lath adjacent to the damaged tile.

- c. Broken tile shall be removed in such a manner as to ensure the functional integrity of the remaining tile and provide for satisfactory joint replacement and adequate support of the replacement section.
- d. Reused tile shall be thoroughly cleaned.
- e. Tile shall be replaced so that its former gradient and alignment are restored.
- f. The soil beneath and around all replaced tile lines shall be firmly hand tamped at the ditch sides.
- g. All permanent drain tile replacements are to be in strict accordance with the Landowner Agreement, the following requirements and as shown in DRAWINGS.
- h. A single continuous supporting member shall be placed across the trench as a trough in which to lay replacement tile.
- i. The supporting member shall span the trench and have a minimum of two (2) feet of solid bearing under each end.
- j. The **CONTRACTOR** shall fabricate and weld the material into shapes and lengths as shown on the DRAWINGS to properly support the tile line.
- k. In cases where the original tile line very nearly parallels the pipe, the tile line shall be relaid for some distance on both sides of the trench such that it crosses the pipeline at a suitable angle.
- l. Before completing permanent tile replacements, the **CONTRACTOR** shall examine, by suitable means, the adjacent tile lying beneath the working side of the RIGHT-OF-WAY to assure that such tile has not been crushed, plugged, misaligned or otherwise disturbed as a result of the **CONTRACTOR'S** activities.
- m. The excavated pipeline trench shall provide a minimum of twelve (12) inches clearance between the top of the pipe and the bottom of the tile. At locations along the RIGHT-OF-WAY where future underground tile is proposed, the pipeline trench shall be excavated to the required depth to provide the specified clearance. Such excavations will be at **CONTRACTOR'S** expense.

19. CLEAN-UP

- a. All clean-up and restoration shall be performed in accordance with the Environmental Mitigation Plan, the Agricultural Mitigation Plan or Agreement, and the CONSTRUCTION LINE LIST, and the applicable SPECIFICATIONS.
- b. The **CONTRACTOR** shall keep the RIGHT-OF-WAY cleared daily of paint barrels, skids, defective materials, coating waste, electrode stubs and all other construction debris immediately behind the operations of all crews, to the satisfaction of the property owners and the **COMPANY**, and dispose of such wastes at a location acceptable to the **COMPANY**.

- c. Upon completion of the backfill, the **CONTRACTOR** shall clear and dispose of all rock three (3) inches in diameter or larger, stumps or other remaining debris, fill holes, ruts and depressions, and the RIGHT-OF-WAY shall be left in a neat and acceptable condition. The **CONTRACTOR** shall exercise care to insure that no cast-off cable, wire, machinery parts, skids, timbers or logs are left buried or imbedded in the RIGHT-OF-WAY or adjacent lands.
- d. As general clean-up is completed all topsoil will be returned to its original location and depth and then lime and fertilizer shall be applied as necessary – Refer to Erosion Prevention and Sediment Control Plan. Paratilling, chisel plowing, wind rowing, and rock picking shall then be performed on the CONSTRUCTION RIGHT-OF-WAY and TEMPORARY WORK SPACE areas. All rock three (3) inches and larger measure in any dimension shall be removed in accordance with the Agricultural Mitigation Plan or Agreement in all agricultural and pasture lands across the entire CONSTRUCTION RIGHT-OF-WAY width and disposed of at the CONTRACTOR'S expense. The **CONTRACTOR** shall be required by the **COMPANY** and certain governmental agencies to seed and/or mulch, certain CONSTRUCTION RIGHTS-OF-WAY and temporary WORK space areas used during Construction according to the governing authority. The **COMPANY** will specify the seed mixes to be used. The **CONTRACTOR** shall furnish such seed, lime, fertilizer and mulch.
- e. CONTRACTOR shall at his own expense be responsible for the repair and maintenance of roadways, lands, terraces, and levees subjected to his activities in the construction of the pipeline.
- f. All lawns or yards or private roads crossed will be restored to the satisfaction of the landowners and the **COMPANY**.
- g. All temporary access to the RIGHT-OF-WAY will be removed and such areas will be restored to the condition found as directed by the **COMPANY INSPECTOR**.
- h. All fences and gaps will be restored to the condition found prior to the WORK. All materials used shall be equal to or better than existing.
- i. Clean-up shall follow backfill operations as close as practical.
- j. All **COMPANY** designated material, staging, and pipe yards used by the **CONTRACTOR** will be returned to the condition found prior to beginning the WORK, as directed by the **COMPANY INSPECTOR**.
- k. All backfill and clean-up operations shall be completed, when practical, prior to the commencement of hydrostatic testing.
- l. All clean-up work attempted during inclement weather will be redone, if required, at the **CONTRACTOR'S** expense.

- m. Permanent water bar spacing shall be in accordance with the Erosion Prevention and Sediment Control Plans or relevant permits. If the Environmental Mitigation Plan and permits differ, the more stringent shall apply.
- n. Following the completion of the clean-up and permanent repair of fences for any respective property and after the **COMPANY'S** general approval of such clean-up, but prior to "Payment of Retainage", the **CONTRACTOR**, with the **COMPANY RIGHT-OF-WAY AGENT PRESENT**, will obtain a signed "CONSTRUCTION PERFORMANCE CLEAN-UP MEMORANDUM" (or other form identified by the **COMPANY**) from all landowners, occupants, tenants and other authorities having jurisdiction, acknowledging that the clean-up WORK has been completed to their satisfaction. The **CONTRACTOR** shall provide the **COMPANY** with copies of the memorandum as soon as practical to facilitate payment of damage to the landowner.
- o. If the landowner or tenant refused to sign "Construction Performance Clean-up Memorandum", the **CONTRACTOR** shall attempt to obtain a signed statement from landowner and/or tenant setting forth the reason(s) for such refusal. One copy of this statement shall be furnished to the **COMPANY**.

20. CONTINUOUS CONCRETE WEIGHT COATING

- a. Continuous concrete weight coating of pipe shall be installed in locations as required in the DRAWINGS. **CONTRACTOR** will own any surplus concrete coated pipe. The **CONTRACTOR** shall comply with the following specifications:
- b. One layer of tar felt paper shall be placed along the top of the pipe. The tar felt paper shall be approximately one foot wide and will serve to protect the fusion bonded epoxy coating from the aggregate as it falls from the chute. Coating protection, approved by the **COMPANY**, in the form of either tar felt paper or pipeline type tape, shall also be placed under the form support blocks to prevent damage to the epoxy coating.
- c. Weight coating for pipelines shall be reinforced concrete. The concrete shall develop a minimum allowable compressive strength of 3,000 psi at 28 days, in accordance with the CONCRETE SPECIFICATIONS in the DRAWINGS. Should the results of the concrete cylinder tests fail to meet these requirements, the Structural Concrete Specification requirements shall apply. The strength and density will be tested by the Company's representative. Minimum concrete density used shall be approximately 140 lbs./ft. and maximum concrete density is 190 lbs./ft. Samples shall be taken by the **COMPANY** for testing at the rate of four (4) samples per thousand feet of pipe.
- d. Internal support shall be placed inside the pipe to prevent out of round (egging) from occurring from the concrete coating. Wooden skids, contoured to fit the

pipe curvature, shall be placed in the ends of each pipe joint prior to pouring the concrete coating. Internal skids may be removed in five days after pouring.

- e. The cutback on the concrete coating for the poured sections shall be fourteen (14) inches. Joint ends must be kept covered and clean during the application of concrete.
- f. Reinforcing shall be applied prior to concreting and shall consist of 2"x2" sixteen gauge galvanized wire mesh. The reinforcement shall be overlapped not less than eight (8) inches.
- g. Form spacers shall be used to keep the pipe forms concentric with the shape. Such spacers shall be of masonry material approved by the **COMPANY'S** representative. Spacers shall be of adequate height to insure the required concrete thickness as set forth on the Drawing. The welded wire mesh shall be securely tied to the spacers to prevent any movement while pouring.
- h. The forms shall be securely held in place around the spacers to insure proper application and uniform coating of the pipe. The concrete poured shall be vibrated to produce a dense, homogenous, smooth surface with a uniform thickness with no variations in weight per linear foot. The method of vibration shall be approved by the **COMPANY**. No one section of coated pipe shall contain honeycombs or high porosity. Honeycombs or porosity may be repaired with grouting at the **CONTRACTOR'S** expense.
- i. When ready mixed concrete is used, a copy of each batching ticket of the ready mix supplier shall be furnished by the **CONTRACTOR** to the **COMPANY**.
- j. Concrete coated pipe shall possess a minimum negative buoyancy of 10% (1.10 S.G.). The **CONTRACTOR** will demonstrate that the thickness and density of the concrete applied shall result in the specified specific gravity.
- k. The first joint of pipe for each coating thickness shall be weighted after application and curing. The mix shall be adjusted as required to meet the specified weight.
- l. The **CONTRACTOR** shall exercise due caution in handling, storing and transporting the coated pipe.
- m. Repairs to damaged weight coating shall be made as follows:
 - A. If the coating damage is less than 25% of the coating thickness and less than one (1) square foot in area, repairs shall not be required.
 - B. If the coating damage is less than 25% of the coating thickness and more than one (1) square foot, but less than ten (10) square feet in area, the damage will be repaired by exposing the reinforcing mesh and repairing with a suitable concrete mixture of grout.

- C. Damage to the coating not covered above will be repaired by exposing the entire periphery of the pipe throughout the damaged area, installing a metal form and replacing all materials.
- D. Cracks in excess of one sixteenth (1/16) inch in width and twelve (12) inches in longitudinal length or in excess of one sixteenth (1/16) inch in width and extending over 180 degrees circumferentially, shall be repaired to the satisfaction of the **COMPANY**.
- E. All repairs to weight coating shall be properly cured. Failure to comply with the SPECIFICATIONS shall constitute cause for rejection of the coated pipe.
- n. Concrete forms shall be left on a minimum of twenty four (24) hours. Once forms have been removed, the concrete coated pipe shall not be moved for a minimum of 72 hours.
- o. With or without non-chloride admixtures – Temperature of the concrete must be maintained and monitored as follows.
 - A. 0-24 hours – Concrete temperature no less than 55° F.
 - B. 24-48 hours – Concrete temperature no less than 50° F. °
 - C. 48-120 hours-Only protective covering is required if ambient temperature falls below 40° F. No concrete temperature monitoring is required after 48 hours.
 - D. The concrete temperature should be measured with contact thermometers during the first 48 hours after it has been poured. Temperatures shall be checked on 10% of each day's production.
 - E. When the mean daily ambient temperatures fall below 40°F, the use of non-chloride, non-corrosive accelerator must meet the requirements of ASTM C494, Type C. Calcium chloride is not acceptable for continuous concrete coating.
- p. **COMPANY** designated pipe shall be concrete coated.

21. ROAD CROSSINGS

- a. The **COMPANY** will obtain the necessary permits from state, county, and other jurisdictional authorities for pipeline crossings of roads identified on the DRAWINGS and CONSTRUCTION LINE LISTS. The **CONTRACTOR** shall construct each crossing in accordance with the permit and the **COMPANY'S** DRAWINGS, as applicable. In situations where the permit stipulations are less than the **COMPANY'S** requirements, then the **COMPANY'S** requirements shall govern. Copies of permits or information concerning crossings will be given to the **CONTRACTOR**. It shall be the **CONTRACTOR'S** responsibility to furnish and install at all crossings adequate and proper traffic aids, warning signs, barricades, flares and other safeguards necessary for public safety and to maintain them throughout the duration of the work. Any specialized insurance that is required

by any permitting authority having jurisdiction over any road will be at the **CONTRACTOR'S** expense.

b. OPEN CUT CROSSING

- A. The locations of open cut roads will be as designated by the **COMPANY**. Installation will be in accordance to Drawing specifications.
- B. The **CONTRACTOR** shall immediately backfill that portion of the ditch which crosses the road after the pipe is installed. Backfill in pipe trenches crossing roadways shall be compacted to a minimum of 95 percent of modified Proctor maximum dry density. Backfill materials shall be placed with water content within plus or minus 3 percent of optimum moisture content per the modified Proctor method (ASTM D1557). Any water used for compaction shall be provided by the Contractor at his own expense. The Contractor is responsible for the repair of any trench settlement at no expense to the **COMPANY**.
- C. Backfilling, compaction and surface restoration will meet the requirements of the jurisdiction issuing the permit and also any **COMPANY** requirement. The compensation for such **WORK** shall be included in the pricing for such **WORK** in the **BID DOCUMENTS**.
- D. Proper traffic control meeting Federal and State D.O.T. requirements will be provided by the **CONTRACTOR** at **CONTRACTOR'S** expense.
- E. Any shoring or well pointing, if required, will be at **CONTRACTOR'S** expense.
- F. All excavations shall comply with current OSHA Standards.
- G. Refer to Specification 31233 Trenching and Backfilling for additional requirements.

c. BORED CROSSING

- A. The locations of the bore crossings will be as designated by **COMPANY**.
- B. The bore hole shall not exceed the pipe diameter by more than one and one-half (1- 1/2) inches.
- C. Any shoring or well pointing, if required, will be at **CONTRACTOR'S** expense.
- D. All excavations shall comply with current OSHA Standards.
- E. Should the bore prove unsuccessful, the void created shall be filled with concrete at the **CONTRACTOR'S** expense. All **COMPANY** material so wasted will be replaced at the **CONTRACTOR'S** expense. Any additional expense incurred in acquiring new permits or **RIGHT-OF-WAY** will be at the **CONTRACTOR'S** expense.
- F. The **CONTRACTOR** will provide the "Deadman" and "Dummy Pipe", as necessary.
- G. Road boring methods shall comply with State and Local Regulations.

- H. Welded pipe joint final locations should be minimized under road surfaces. If pipe joints under a travelled way is unavoidable, prior to pipe installation, CONTRACTOR shall review with OWNER location of welds and an alternative mechanical protection, approved by the OWNER, shall be installed around weld.

22. RAILROAD CROSSINGS

- a. The COMPANY will obtain the necessary permits from federal, state and other jurisdictional authorities for pipeline crossings of railroads identified on the DRAWINGS and CONSTRUCTION LINE LISTS. The CONTRACTOR shall construct each crossing in accordance with the permit and the COMPANY'S DRAWINGS, as applicable. In situations where the permit stipulations are less than the COMPANY'S requirements, then the COMPANY'S requirements shall govern. Copies of permits or information concerning crossings will be given to the CONTRACTOR. It shall be the CONTRACTOR'S responsibility, at all crossings, to furnish and install adequate and proper traffic aids, warning signs, barricades, flares and other safeguards necessary for public safety and to maintain them throughout duration of the work. Any specialized insurance that is required by any permitting authority having jurisdiction over any railroad will be at the CONTRACTOR'S expense.
- b. BORED CROSSINGS
 - A. The locations of the bore crossings will be as designated by the COMPANY.
 - B. The bore hole shall not exceed the casing pipe diameter by more than one and one half inches.
 - C. Any shoring or well pointing, if required, will be at the CONTRACTOR'S expense.
 - D. All excavations shall comply with current OSHA Standards
 - E. Should the bore prove unsuccessful, the void created shall be filled with concrete at the CONTRACTOR'S expense. All COMPANY material so wasted will be replaced at the CONTRACTOR's expense. Any additional expense incurred in acquiring new permits or RIGHT-OF-WAY will be at the CONTRACTORS expense.
 - F. The CONTRACTOR will provide the "Deadman" and "Dummy Pipe", as necessary.
 - G. Railroad boring methods shall comply with Federal and State Regulations.

23. RIVER, STREAM AND WETLAND CROSSINGS

- a. Construction of pipelines at rivers, including major rivers, and at streams and other water crossings shall be performed in such a manner as to minimize damage to shorelines, waters crossed, adjacent drainage areas, fish and wildlife habitats and recreational areas, in accordance with the SPECIFICATIONS, the Project Permits, and requirements of any governmental or other authority having jurisdiction there over and as prescribed in these SPECIFICATIONS. Minimum depth of cover will be specified in the BID DOCUMENTS.

- b. Unless a separate price is stated for specific river, stream or wetland crossing in the BID DOCUMENTS, no additional compensation will be due the **CONTRACTOR** for such work.
- c. All rivers, stream and other wetland crossings shall be constructed using the “free stress” or field bend (sag/overbend) method of construction unless specified otherwise. The **CONTRACTOR** will be responsible for installing and removing all bridges required for river, stream, and wetland crossings at the **CONTRACTORS** expense.
- d. All river and stream bank restoration will be according to the conditions as set forth in the SPECIFICATIONS, Environmental Mitigation and applicable permits.
- e. The **CONTRACTOR** will be required to conduct the WORK in such a manner as to minimize obstruction in navigable waters.

24. NON-DESTRUCTIVE TESTING

- a. The **COMPANY** shall supply all labor, materials and facilities to meet the requirements of the latest addition of API 1104. See Drawings.
- b. The **COMPANY** shall furnish all labor, material and equipment to provide all NDT of all pipeline welds and to provide and interpretation of such examination. 100% of girth welds shall be examined radiographically as well as visually. Personnel performing such examination shall be qualified as ASNT Level II as a minimum.
- c. Marking of all weld information on the pipe is the responsibility of the **CONTRACTOR**.
- d. All examination results will be furnished to **COMPANY** and will be reviewed by **COMPANY**. The **COMPANY** interpretation will be the final decision as to the acceptance or rejection of any weld.
- e. The **COMPANY** is fully responsible for supporting and coordinating NDT crews so as to cause no delays to the project. Any costs associated with such delays shall be at the expense of the **COMPANY**.

25. HORIZONTAL DIRECTIONAL DRILLING

- a. The **CONTRACTOR** has the option to directional drill crossings, subject to the **COMPANY'S** approval and SPECIFICATIONS and PERMITS; however, the **CONTRACTOR** shall not receive any additional compensation for the option to directional drill.

26. HYDROSTATIC TESTING

- a. Prior to commencing the Hydrotest activities, **CONTRACTOR** shall provide, for **COMPANY** approval, a hydrotest plan and procedure, which shall include a temporary evacuation and security plan.
- b. All hydrostatic testing shall be performed by **CONTRACTOR** and approved by the **COMPANY**. The Pipeline and appurtenances shall be pressure tested to a pressure, time and procedure as specified in this Specification, the Department

of Transportation CFR 49, Part 192, latest edition, and ANSI B31.8, latest accepted edition. Such WORK shall include, but not be limited to, cleaning and preparing pipeline for test, filling and dewatering the pipeline, making repairs in the event of failure, drying the pipeline, and reconnecting or capping the pipeline following successful completion of the test. Filters, subject to approval by **COMPANY**, shall be used for filling operations of hydrostatic testing, unless clean well or domestic water is used. Dewatering shall be performed in accordance with the **COMPANY'S** Environmental Permits, discharge permits, and all applicable Federal, State and local Regulations.

- c. All record keeping will be the responsibility of the **CONTRACTOR**. The original and two (2) copies of all hydrostatic test records are to be submitted to the **COMPANY** upon completion of each hydrostatic test. Each hydrostatic test must be approved by the **COMPANY** prior to the depressurization of the test station.
- d. The **COMPANY** will furnish DRAWINGS detailing the number and length of each test section, the test pressures required, and the pipeline profile.
- e. The **COMPANY** will supply a Test Engineer to witness the hydrostatic tests. The **CONTRACTOR** shall supply personnel experienced with the operation of all required testing instruments and equipment in accordance with the provisions of this **CONTRACT**.
- f. The **COMPANY** will secure Hydrostatic Test Water Discharge Permits. Copies of the Hydrostatic Test Water Discharge Permits will be furnished to the **CONTRACTOR**.
- g. Water used for testing purposes shall comply with water discharge permits and be kept free of additives including acids or other material detrimental to the pipe metal. Unless otherwise specified, the **COMPANY** shall be responsible for supplying water acquisition sites and permits and the **CONTRACTOR** will abide by any restriction therein. **CONTRACTOR** shall utilize commercial or public water sources, unless otherwise approved by the **COMPANY**. All efforts will be made to locate the water source on the Working side of the RIGHT-OF-WAY
- h. The **CONTRACTOR** shall furnish equipment which complies with the following specifications:
 - A. Fill lines and pumps shall be in good operating condition, capable of pumping a minimum of one thousand five hundred (1500) gallons per minute to a pressure of two hundred (200) psi.
 - B. Filters shall be installed between all unprocessed water sources and the pipeline. Filters shall be equipped with one hundred (100) mesh screen or equivalent and capable of removing particles one hundred sixty (160) microns and larger. Filters shall be installed in such a manner to

permit back flushing or change out without interruption of the pumping operation and without bypassing the filtration system.

- i. High-pressure pumps shall be in good operating condition, capable of pumping a minimum of fifty (50) gallons per minute, and rated at least fifty-percent (50%) above maximum required test pressures. Pumps shall be equipped with a stroke counter or other means of volume measurement and a variable speed control to reduce capacity to three (3) gallons per minute. High pressure pumps shall be mobile enough to allow movement from one location to another without causing delay.
- j. Air compressors required for dewatering shall have a total capacity of not less than 1200 CFM.
- k. Deadweights shall be installed at one end of each test section, whereas a pressure recorder and ambient and pipe temperature recorders shall be installed at both ends of each test section, as designated by the **COMPANY**. The following minimum requirements shall be met:
 - A. Deadweight pressure gauges 0-3000 psig with readings to the nearest 1 psig, complete with a current test certificate in accordance with the requirements of the governing authorities.
 - B. Pressure recording gauges 0-3000 psig with twelve (12) inch minimum diameter or width chart with pressure increments of 20 psig maximum complete with a current test certificate in accordance with the requirements of the governing authorities.
 - C. Pressure dial gauges 0-3000 psig, six (6) inch minimum diameter with pressure increments of 30 psig maximum.
 - D. Temperature recording gauges for pipe temperature, soil temperature and air temperature, 32 deg. F. – 120 deg. F. twelve (12) inch minimum diameter with temperature increments 1deg F maximum, complete with a current test certificate in accordance with the requirements of the governing authorities.
- l. A suitable building or trailer, approved by the **COMPANY**, with proper chairs (5), tables (2), lighting and heat and installation of a **COMPANY** supplied radio for communications shall be provided and/or installed by the **CONTRACTOR** at each test site, to house test instrumentation and personnel.
- m. The **CONTRACTOR** shall provide test manifolds with the exception of the line pipe provided by the **COMPANY**. The **CONTRACTOR** shall install manifolds at locations designated by the Company. **CONTRACTOR** shall provide the following for the test header:
 - A. Material test reports on the header pipe, cap and fittings, with a complete bill of materials.
 - B. X-rays of each weld on the test manifold/header
 - C. Serial numbers on each valve.

DRAFT

- D. Valves and fittings clearly stamped with ASTM, API, ASME specifications.
 - E. Traceable materials including heat numbers, where applicable.
 - F. Visual examination of the testing materials for dents, gouges or other damage
- n. The **CONTRACTOR** shall perform and provide a pressure-volume (P-V) plot for hydrostatic tests.
- o. The **CONTRACTOR** shall, within thirty (30) days after award of Contract, submit the following data to the **COMPANY** for approval:
- A. A list of all instrumentation to be used showing manufacturer rating, range, accuracy, limits, etc., complete with certified copies of all calibration reports. Certification to be current within 6 months.
 - B. A detailed section line fill, test procedure and schedule.
- p. The **CONTRACTOR** shall ensure that the pipeline and appurtenances are free of dirt and debris prior to filling the test section and that all valves are fully open. The **CONTRACTOR** shall furnish compressed air to run a minimum of one (1) **CONTRACTOR** furnished wire brush pig with cups. The **COMPANY** may request additional runs at no additional cost to the **COMPANY**.
- q. Filling shall be continuous and accomplished with one (1) of more bi-directional squeegee pigs (four (4) disk minimum) furnished by the **CONTRACTOR**. The **CONTRACTOR** shall regulate the speed of travel of the fill pig(s) to the satisfaction of the **COMPANY** in order to prevent water from bypassing the pigs during the filling and dewatering operations. The **CONTRACTOR**, at no additional cost to the **COMPANY**, shall cut from the line any pig which stops during filling, dewatering or drying, and cannot be dislodged, and repair the line in accordance with the **COMPANY'S** Specifications.
- r. The temporary piping at the fill point shall include a water meter and a recording pressure gauge for the purpose of estimating the location of the fill pig. A check valve shall be installed at the point where the fill pump discharge piping is tied into the pipeline.
- s. All buried pipeline and appurtenances shall be tested to the pressure designated by the **COMPANY** for a period of eight and one-half (8.5) continuous hours; whereas, pre installation (above ground) testing shall be for a period of four and one-quarter (4.25) continuous hours. The **COMPANY** Test Engineer shall be present during the pressurizing operation. Pipe installed at specified crossings shall be hydrostatically tested at a pressure specified by the COMPANY (for four and one quarter (4.25) hours) prior to installation. This includes some HDD crossings.
- t. The **CONTRACTOR** shall connect two pressure recorders (one at each end), deadweight test pressure gauge and four temperature recorders (one in the backfill at pipeline depth and one on the pipe, at each end of the pipeline) to the pipeline before the start of the test pressurizing. Starting at sixty (60) percent of the test pressure specified for the test point location, the pressure shall be

continually checked with the deadweight test gauge until the specified test pressure is reached. Also, during this portion of the test, the volume of test medium added shall be measured by one of the following methods:

A. A calibrated turbine meter and totalizer installed in a manner approved by the COMPANY.

B. A counting device installed on the positive displacement pump which will record the number of pump strokes.

- u. At Sixty (60) percent of the specified test pressure a stabilization period shall start. The temperature stabilization period of the test medium shall be continued for a minimum of one (1) hour and until a temperature-time plot is asymptotic to the ground temperature. During the stabilization period, all appurtenances (mainline valves, test connections, etc.) shall be checked for leakage and be in the open position for the remainder of the test.
- v. After termination of stabilization period, the yield plot will commence. A constant pumping rate will be maintained to obtain a suitable pressurizing rate of not more than 15 psi increase per minute. As each 15 psi increment is indicated on the deadweight gauge, the cumulative volume of test medium added shall be recorded. This pressure and volume information shall be recorded in tabular form and immediately transferred to produce a graph of pressure versus cumulative volume or "yield plot". The yield plot will form a straight line until the elastic limit of a portion of the pipe is reached, at which time it will gradually curve to the right of the projected straight line. Pressurizing shall cease when either the required test pressure has been reached or a pressure has been reached which corresponds to a deviation from a straight line proportionality of 0.2 percent (offset method on the pressure volume plot for the section being tested).
- w. Pipe installed at specified crossings shall be hydrostatically tested for four hours at a pressure specified by the COMPANY, both prior to, and after installation.
- x. The **CONTRACTOR** shall not be permitted to tighten or otherwise disturb any flange or pipeline appurtenance that is under pressure.
- y. After successful completion of the test and after approval by the **COMPANY** Test Engineer, the pressure shall be bled down only to the hydrostatic head at the bleed off point. The bleed off point shall be the highest point of the two ends in the Test Station, the intent being to bleed excess pressure from the pipeline while preventing air from entering the pipeline.
- z. The **CONTRACTOR** shall be required to comply with all applicable water acquisition and dewatering permit requirements furnished by the **COMPANY** and in accordance with the **COMPANY'S** Environmental Mitigation Plan. The **CONTRACTOR** shall obtain approval from the **COMPANY** Test Engineer before discharging any test water.

- aa. Dewatering shall be accomplished with one (1) or more bi-directional **COMPANY** approved four (4) disk squeegee pigs that are not excessively worn or damaged and one (1) or more bi-directional poly pigs furnished by the **CONTRACTOR**. The bi-directional poly pig may be loaded in the receiving manifold prior to the filling operation such that it may be run in combination with the squeegee fill pig during the initial dewater run.
- bb. Drying shall be accomplished utilizing compressed air furnished by the **CONTRACTOR** with **COMPANY** approved directional squeegee or poly pigs furnished by the **CONTRACTOR**. A minimum of two (2) separate air propelled runs will be run. Additional foam pig drying runs may be requested by the **COMPANY** at the **CONTRACTOR'S** expense. The **CONTRACTOR** shall provide pipeline dryers to achieve a minus 40 degree dew point of the finished pipeline. Pipeline dryers and labor to be furnished by the **CONTRACTOR** at no additional expense to **COMPANY**. **CONTRACTOR** shall demonstrate recent calibration (within the previous three (3) months) of dew point tester.
- cc. Whenever possible, all fabricated assemblies shall be hydrostatically tested as an integral part of the mainline pipeline, in accordance with these Specifications. However, situations may arise which result in the fabricated assemblies not being in place at the time of mainline testing. With prior written approval of the **COMPANY**, fabricated assemblies may be proof tested above ground for eight (8) hours duration, prior to installation in the pipeline. Such tests shall be performed in general accordance with these Specifications, Department of Transportation Regulations and ANSI B31.8.
- dd. If any leaks or breaks occur during any of the testing operations, the **CONTRACTOR** shall locate, repair and retest the Test Section in which the failure took place. The **CONTRACTOR** shall immediately notify the **COMPANY** of all pipe failures and all suspected leaks complete with all particulars.
- ee. Leaks or breaks occurring in the pipe metal or pipe seam shall be repaired by cutting out and replacing the entire joint. If the leak or break has been caused by construction damage only and is in a straight joint of pipe, it will not be necessary to replace the full joint and repairs shall be as directed by the **COMPANY**. Leaks occurring in the circumferential welds shall be replaced with a 10ft minimum length pup. Failures occurring in field bends shall be replaced with field bends of the same degree. No cuts shall be made closer than twelve (12) inches to a defect.
- ff. For all leaks and breaks, accurate records shall be kept from the time the leak or break is first indicated until it has been located, repaired, refilled and re-pressurized to the same pressure at which the failure was first indicated. Records shall detail the quantities of materials and supplies used. All supervision, labor, and equipment shall be classified by operational and standby time.

DRAFT

- gg. All pipeline sections containing leaks or breaks which are cut out of the pipeline shall be handled in accordance with the pipe manufacturer's representatives or the **COMPANY'S** instructions so as not to damage the defective areas. All such cut out pipe shall be clearly marked with paint immediately after removal from the ditch to show the **COMPANY** stationing and date of failure. The edges of the defect shall be protected with grease. Defective pipe shall be transported as directed by the **COMPANY**.
- hh. Leaks or breaks occurring in the pipeline during any of the testing operations which are a result of defective permanent materials furnished by the **COMPANY** shall be located, repaired and the repaired Test Station refilled and re-pressurized to the same pressure which the failure was first indicated, all by the **CONTRACTOR** at the **COMPANY'S** expense.
- ii. During all testing operations, the **CONTRACTOR** shall take all necessary safety precautions to protect all persons and property including the temporary evacuation and lodging of property owners/residents/tenants as required by the **COMPANY'S** SPECIFICATIONS. This shall include, but not be limited to, keeping all persons not directly engaged in the testing operations off the CONSTRUCTION RIGHT-OF-WAY of the test section during the pressure stabilization and holding periods. Warning signs shall be placed along the RIGHT-OF-WAY at points of public crossings and must remain in place throughout the pressurizing and holding periods.
- jj. The deadweight pressure gauge, pressure recorder, and dial pressure gauge shall be tied into a common manifold which is connected to the Test Section by a high pressure hose. This manifold and the instrumentation shall be located a minimum of fifty (50) feet from the Test Section being tested. The same criteria shall hold true for the pressure recorder and dial pressure gauge located at the other end of the test section. **CONTRACTOR** shall demonstrate recent calibration (within the previous three (3) months) of the deadweights and chart recorders.
- kk. The **COMPANY** will furnish the forms for and the **CONTRACTOR** shall prepare the following records for each Test Section:
 - A. Log of deadweight pressure readings taken every 15 minutes during stabilization period, yield plot and eight (8) hour hold test.
 - B. Pressure recording charts for:
 - 1. Pressurizing and stabilization period
 - 2. Eight (8) hour hold test.
 - C. Temperature recording charts for:
 - 1. Pressurizing and stabilization period
 - 2. Eight (8) hour hold test.
 - D. Report on any leak or break including location, pressure, dimensions of defect, pipe manufacturer heat number and joint number, how repaired, etc.

- ll. All the above records shall show the size and name of the pipeline, the location of the Test Section, the location of the test gauge, and the quantities of each wall thickness of pipe included in the Test Section, and the starting and ending times/dates of tests. These records shall be signed by the authorized representatives of the **CONTRACTOR** and the **COMPANY**. Original signed copies of all records for each Test Section shall be turned over the **COMPANY** immediately after the successful completion of the test in that section. All records shall be in accordance with DOT Part 192.
- mm. All testing operations involving work on the RIGHT-OF-WAY or on the pipeline, including but not limited to move-in/move-out, cutting fences, handling the **COMPANY** furnished materials, bending, welding, coating, tie-ins and backfilling shall be in accordance with the applicable sections of the **SPECIFICATIONS**.
- nn. All areas disturbed by any of the testing operations, including but not limited to filling, pressurizing, failure repairs, buckle repairs, manifold or temporary scraper trap removal and water damage to previously cleaned-up RIGHT-OF-WAY shall be cleaned up immediately after testing operations have been completed in accordance with these Specifications.

27. **GEOMETRY PIG**

- a. The **CONTRACTOR** is responsible to demonstrate conformity with API 5L, ASME B31.8, other related standards, and VERMONT GAS SYSTEMS policies and procedures by the use of a "geometry pig" (charted dent tool). The tool used shall be an ENDURO DDL Pig or approved equivalent. Prior to commencing any Geometry Pig activity, **CONTRACTOR** shall present for **COMPANY** approval, tool specification and vendor, if other than what is above.
- b. Upon completion of the drying of the pipeline to a minus 40 degree dew point, which follow the hydrostatic testing, and after installation of mainline valves, the **CONTRACTOR** shall furnish all labor, supervision, services, supplies, materials, equipment and instrumentation including any temporary launching and receiving traps required to perform one successful run of the "geometry pig" through the completed sections of the pipeline. The **CONTRACTOR** shall submit a plan for benchmarking the "geometry pig" run to the **COMPANY** for approval. The benchmarking data shall have above ground reference points spaced no further than 3 miles, but with a 2 mile average. Should an inconclusive chart be produced due to any reason whatsoever, the "geometry pig" shall be rerun entirely at the **CONTRACTORS** expense until a satisfactory chart is produced.
- c. In order to best attain a constant pig speed, the pipeline shall first be pressurized with air, furnished by the **CONTRACTOR**, to approximately 50 psi on the downstream side of the pig prior to launching. The pressure shall be maintained during the entire pig run by regulating the discharge rate of the blowdown valve at the downstream end of the section to approximately 50 psi. Ideally, the operator should maintain a 3 or 4 m.p.h. speed or per the manufacturer's

recommendation. The contractor shall insure inlet air pressure, volume, hoses, in-let header, and etc. to ensure adequate head, differential and pressure is maintained during the entire “geometry pig” tool run. The maximum length of section to be pigged at one time shall be the length of the hydrostatic test section, unless approved in writing.

- d. A summary of the ‘geometry pig” run shall be provided to the **COMPANY** for review and acceptance. At a minimum, the report shall include:
- A. Summary of tool logistics including maximum speed, minimum speed, average speed, data quality, Vendor assurance of 100% coverage and etc.
 - B. An Excel spreadsheet containing a summary of the following:
 - 1. Reference to pipeline stationing
 - 2. All dents greater than 2% of pipe diameter
 - 3. All combination dents and ovality greater than or equal to 5% of pipe diameter.
 - 4. Ovality greater than 5% of pipe diameter.
 - 5. All bore restrictions greater than or equal to 6% of pipe diameter.
 - 6. All welds.
 - 7. All pipe and wall thickness changes.
 - 8. Location and radius of all bends.
 - 9. Location and description of all fittings, tees, valves, and etc.
 - 10. Benchmarking data
 - C. Software to review and analysis data.
 - D. The report shall adhere to the following Reporting Standards.
 - 1. **(In-Line Inspection, Geometry, and Tracking Vendor Reporting Standards Hard Copy Information And Electronic Documentation)**
 - a. **Hard Copy Report – Title Page (3 Ring Binder)**
 - i. Vendor’s Logo
 - ii. Line Number
 - iii. Diameter of Pipe (Imperial and Metric)
 - iv. In-Line Inspection run from trap – trap section (e.g. Regina – Cromer)
 - v. Trap = Trap (Milepost and Kilometer)
 - vi. Run Date: Month, Day, and Year
 - vii. **Type of tool used for run: (e.g. Elastic Wave, Metal Loss, Scout Scan, etc)**
 - viii. Book Numbering (e.g. Book 1 of 1) Bottom right hand of the page.
 - ix. GPS (If Applicable)

b. Spine – Hard Copy Report (3 Ring Binder)

- i. Vendor's Logo
- ii. Line Number
- iii. Diameter of Pipe (Imperial and Metric)
- iv. In-Line Inspection run from trap – trap section (e.g. Regina – Cromer)
- v. Run Date: Month, Day, and Year
- vi. Book Numbering (e.g. Book 1 or 1)
- vii. GPS (if Applicable)

c. Electronic Documentation – Compact Disks and/or DVD

i. Jewel Case - Spine

1. Vendor's Name, Initials or Logo
2. Month and Year of Run
3. Diameter of Pipe (Imperial)
4. Tool Type (Metal Loss, Elastic Wave etc)
5. In-Line Inspection Section (Call Signs)
6. Disk Numbering System (e.g. Disk 1 of 2)

ii. Compact Disk and/or DVD

1. Vendor's Name of Logo
2. Line Number
3. Diameter of Pipe (Imperial)
4. In-Line Inspection Section (e.g. Regina-Cromer)
5. Run Date: Month, Day, and Year
6. Application and Data Type (e.g. Excel, Pipe image etc.)
7. Disk Numbering System (e.g. Disk 1 of 1)
8. Vendor's Information
9. Revision Number (IF applicable)
10. GPS (if Applicable)

2. Information Requirements

- a. 1 Set of Hardcopy Information (1 working copy)
- b. Three ring binders will only be accepted.
- c. 1 Set of Electronic Information (1 working copy)
- d. **The In-Line inspection run data criteria and schedule is mandatory.**

- e. If the criterion has changed from the previous run, an electronic file with the analysis
 - i. With the previous criteria and the current run data is required. Documentation regarding this information being available is required within the hard copy report.
- f. Include Internal Inspection Questionnaire used for the specified run.

3. **Revision Requirements**

- a. A revision to either the hard copy of electronic documentation requires an explanation for the revision, inserted in the hard copy issue of the report.
- b. Revisions require re-issue to both sets of documentation.
- c. Provide revision number, month of revision and year.
- d. The maximum allowable pipe defect shall be as specified in ANSI ASME B31.8, API 1160, and API 5L and the following Company Specifications;
- e. All dents greater than 2% (regardless of orientation), any dents with metal loss, and all dents or ovality greater than or equal to 5 percent shall be replaced at the **CONTRACTOR'S** expense. If the analysis of the calibrated pig "geometry pig" run, as determined by the caliper approved vendor technician, shows indications of pipe defects exceeding these allowable limits, the **CONTRACTOR** shall locate and correct the defects and the "geometry Caliper Pig" shall be rerun to the satisfaction of the **COMPANY**, all at no additional cost to the **COMPANY**.
- f. One running of the calibration instrument pig shall be included in Lay Price Bid of the Bid Documents. This one run of the "Caliper Geometry Pig" is for the entire length of the pipeline laid. Additional runs of the "Caliper Geometry Pig" where requested by the **COMPANY** and which were not the liability of the **CONTRACTOR**, shall be compensated for in accordance with the Bid Document.

28. COATING AND PAINTING

- a. Whenever painting, the **CONTRACTOR** shall take special precautions to prevent primer or finish paint from being blown onto the existing or newly painted surfaces. All Splattering of primer and finish paint falling on these and nearby surfaces shall be removed by the **CONTRACTOR** at his expense. Paint damage to automobiles or any other structures caused by wind drift shall be the **CONTRACTOR'S** responsibility.

- b. No paint shall be applied at ambient temperatures below 50 deg. F. or on surface temperatures less than 5 deg. F above the dew point.
- c. Unless otherwise specified, surfaces which are abrasive blasted will be done so as to conform to Steel Structures Councils Specification SSPC-SP6 Commercial Blast Cleaning with cleanliness according with NACE #3 to obtain a one to three mil profile. All spent abrasives and dust shall be removed from the surface before the application of any paint.
- d. The **CONTRACTOR** shall supply a paint mil thickness gauge to enable the **COMPANY** to verify dry film thickness of applied paint.
- e. Any paint coating other than Specified shall require specific **COMPANY** approval prior to application.
- f. Crystalline silica sand will not be permitted for use in abrasive blasting operations. The **CONTRACTOR** shall be permitted to use "Black Beauty" or equivalent.
- g. Above ground fabrication piping furnished with thin film fusion bond epoxy coating shall be "brush" blasted to obtain an acceptable anchor pattern prior to painting, subject to approval of the **COMPANY**.
- h. The transition of below grade coating to above grade paint shall have all below grade coatings extend six inches above grade.

29. ENVIRONMENTAL CONSIDERATIONS

a. GOVERNMENTAL RULES AND REGULATIONS

A. The **CONTRACTOR** shall be responsible to abide by all governmental laws, rules and regulations applicable to the **COMPANY** concerning environmental protection and obtain all necessary permits and licenses required under such laws, rules and regulations unless specifically stated otherwise, elsewhere in this **CONTRACT**.

B. Workers to be informed and instructed

1. **CONTRACTOR** shall have all personnel participate in environmental training.
2. The **CONTRACTOR** shall ensure all employees, servants and agents (and by employees, servants and agents of ALL SUBCONTRACTORS) are:
3. Informed of the environmental concerns and special conditions of the construction area.
4. Instructed on the requirements of environmental laws, rules and regulations applicable to the construction area.

C. General Housekeeping

1. The **CONTRACTOR** shall ensure that general rubbish such as food wrapping, garbage and sanitary wastes are confined to RIGHT-OF-WAY and other WORK sites and are collected on a daily basis by each WORK crew. Disposal of said wastes is the responsibility of

the **CONTRACTOR** and shall be in an approved manner at a site approved by authorities having jurisdiction.

2. The **CONTRACTOR** shall ensure that the RIGHT-OF-WAY and/or WORK sites are left in a tidy and workmanlike condition following the cessation of daily activities.
3. No disposal of materials will be permitted off the RIGHT-OF-WAY unless prior approval is obtained from the appropriate authorities.
4. Open burning of waste materials is not allowed.

D. Environmental Disturbance

1. The **CONTRACTOR** shall carry out all WORK under this **CONTRACT** in such a manner as to cause the least possible disturbance or damage to the environment. Continuous efforts shall be made to prevent and control fires; soil erosion; and air, noise and water pollution. In cases where some temporary disturbance or damage is unavoidably caused due to the nature of the construction WORK, the **CONTRACTOR** shall, as soon as possible, remove the cause of such temporary disturbance, repair damage, and in general restore the affected areas to their original or specified condition to the extent possible.

E. Pollution Controls

1. The **CONTRACTOR** shall not permit liquid wastes, fuels or other potential pollutants to be deposited on the ground or into bodies of surface water. Refueling and lubrication changes shall be carried out at a minimum distance of 100 feet from a surface water body to prevent any material spilled from entering the water body. Fuel trucks shall carry at least 25 lbs. of absorbent material at all times. The **CONTRACTOR** shall comply with the COMPANY SPILL PREVENTION, CONTAINMENT AND CONTROL PLAN.

F. Dust Control

1. The **CONTRACTOR** shall exercise care to minimize uncontrolled emissions of dust (particulate matter) from its activities on the RIGHT-OF-WAY and other WORK areas. Particular care shall be taken in residential areas. These measures include watering down the RIGHT-OF-WAY and suspending topsoil stripping and replacement during strong winds. All such control measures taken shall be in accordance with any regulations applicable to the **COMPANY**. The **CONTRACTOR** will furnish, at his expense sufficient water trucks and water to 'wet' the RIGHT-OF-WAY to

control fugitive dust near residential areas and other areas as directed by the **COMPANY**.

G. Construction Noise

1. The **CONTACTOR** shall exercise care to minimize noise from its activities, including blasting, in accordance with local regulations.
2. **The CONTRACTOR shall not perform any work on Sunday, and shall limit work hours on the construction Right of Way** in accordance with applicable Contract Documents. Unless otherwise noted within the Contract Documents, the work hours shall be **as follows**;
 - a. Monday through Friday 7 to 7,
 - b. Saturday 8 to 5, and
 - c. Sunday no work will be permitted

H. Wildlife

1. The **CONTACTOR** shall make every effort to ensure that wildlife encountered along the RIGHT-OF-WAY or other WORK areas are not unduly harassed by equipment or personnel. In certain instances, the **COMPANY** may require additional protective measures to be implemented to prevent disturbance to wildlife and comply with environmental conditions. No wildlife shall be fed. Graded trench exits shall be spaced appropriately to allow egress for wildlife which may become entrapped in the trench. Construction personnel shall not be permitted firearms or pets on the RIGHT-OF-WAY.

I. Archaeological and Heritage Sites

1. In the event that any archaeological or heritage sites are discovered during construction, the **CONTACTOR** shall take immediate measures to protect the site. No artifacts shall be removed from the site. The location of the site shall be immediately brought to the attention of the **COMPANY** who will advise the landowner and the appropriate State authority. Until such time as the site has been assessed by a qualified archaeologist, the **CONTRACTOR** shall cease his activities at the site.

J. Farming Areas

1. The **CONTRACTOR** shall ensure that all equipment brought to the RIGHT-OF-WAY from outside of the local area arrives in clean condition in order to minimize the risk of weed introduction.
2. The **CONTRACTOR** shall make every effort to ensure that livestock are not unduly harassed by equipment or personnel. No livestock

DRAFT - NOT FOR CONSTRUCTION

shall be fed. All gates shall be closed unless a watchperson is maintaining the gate.

K. Noxious Weeds

1. The RIGHT-OF-WAY includes limited areas that are infested with noxious weeds. The **COMPANY** may fence the infested area to minimize the opportunity for spreading the infestation. In areas where the **CONTRACTOR** must travel through the infested areas, the following approaches shall be utilized.
2. Use the minimum amount of equipment to complete construction in the infested area.
3. Minimize the number of passes a single piece of construction equipment has to make through the infested area.
4. Use matting in infested areas where possible to minimize the amount of vegetation soil which comes in contact with construction equipment that passes through the infested area.
5. The Environmental Inspector shall identify the boundaries of the infested area prior to construction. The **CONTRACTOR** shall remove plant material and as much soil as possible from each piece of equipment leaving the infested area. Permits which are currently outstanding may require the establishment of washing stations to prevent noxious weeds from leaving the infested area.

30. GOOD PIPELINE CONSTRUCTION PRACTICES

- a. In accordance with the best pipeline construction practices, the **CONTRACTOR** shall suspend construction during adverse weather or under wet ground conditions where certain construction activities may damage the RIGHT-OF-WAY or the environment. Where the **CONTRACTOR** has not suspended its construction activities voluntarily and the weather or right-of-way conditions warrant a shutdown in the opinion of the **COMPANY**, the **COMPANY** may require the **CONTRACTOR** to cease all or certain construction activities until such time as conditions improve. **In the event of a suspension of work due to weather or wet conditions, the CONTRACTOR shall not be entitled to extra compensation or standby charges.**

31. SPILL PREVENTION AND CONTAINMENT

- a. The **COMPANY** has prepared a Spill Prevention, Containment and Control (SPCC) Plan for the project that outlines emergency response procedures that are to be performed in the case of hazardous material release. Requirement and procedures of the plan shall be followed and the designated response measures shall be strictly adhered to as outlined in the Plan. All fines incurred a result of the **CONTRACTOR'S** failure to adhere to the procedures and measures outlined in the Plan shall be at the **CONTRACTOR'S** expense.

- b. The **CONTRACTOR** shall inspect the construction equipment at frequent intervals for leaking for leaking fuel, hydraulic fluids, and/or lubricants. All leaks so discovered shall be repaired immediately.
- c. The **CONTRACTOR** shall maintain a supply of oil absorbent booms on the right-of-way; the booms shall be on site at all water crossings. If an accidental spill should occur, the **CONTRACTOR** shall make every effort to contain the spilled material and immediately notify the **COMPANY**.
- d. All fixed refueling sites used during construction shall be encircled with an earthen dike and temporary fencing.

32. MATERIAL AND EQUIPMENT SUPPLIED BY THE COMPANY

- a. All COMPANY furnished line pipe will be manufactured in accordance with API 5L requirements with ends beveled for welding. The pipe will be X65 grade. The average joint length for the pipe, by size, is listed as follows:
 - A. 12" TRLS 56' min. average.
- b. Additional specifications and descriptions for the pipe are listed as follows:
- c. Ends: 30 degree bevel
- d. Coating:
 - A. Pritec 10/40
 - B. Nominal 40 mil ARO (drills and select bores)
- e. Type: ERW
- f. Size & Grade 12" OD API 5L-X65
- g. Wall:
 - A. 0.312" line pipe
 - B. 0.375" induction bends
 - C. 0.500" valve sites
- h. Project materials shall be available for loading at the designated COMPANY material yards.
- i. Other COMPANY Supplied Material
 - A. Valves, actuators, fittings, flanges and pipe 2" and above
 - B. Induction Bends
 - C. Casing Pipe, Casing/Carrier spacers, casing end seals
 - D. Mechanical/Electrical components listed on plans as "By Owner"
 - E. AC Mitigation Materials including zinc ribbon, SSD stations, coupon stations and cattle guards
 - F. Cathodic Protection Materials including anodes, rectifiers, cable and connectors
 - G. Fencing and gates around Main Line Valve areas
 - H. Pipeline warning signs and detectable warning tape
 - I. Pipeline aerial markers
 - J. Main line pipe for test leads

- K. Electrolysis test stations
- L. 2,300 timber mats (4'x16')
- j. The COMPANY will provide only those materials specified. The CONTRACTOR shall furnish all other materials required to complete the WORK.
- k. COMPANY provided material will be available for unloading and/or loading at the COMPANY designated material yard. The exception to this is the ARO pipe for HDD operations – CONTRACTOR shall handle/transport/deliver ARO pipe from Swanton, Vermont to the pipe yard and/or right-of-way.
- l. The CONTRACTOR will coordinate with the COMPANY Material Representative when scheduling material loading and/or unloading in order to avoid conflicts and delays. The **CONTRACTOR** shall provide all necessary labor and equipment required to load and/or unload any **COMPANY** provided materials at any **COMPANY** designated material yard(s) in a timely manner. The **COMPANY** will prepare the material transfer report and the **CONTRACTOR** will acknowledge, along with any exceptions, at the time transfer occurs. The **CONTRACTOR** shall plan its WORK to minimize pipe wastage, i.e. cutting pipe in pups less than 3 pipe diameters in length.
- m. The CONTRACTOR shall return surplus materials to the **COMPANY** designated yard. Surplus materials shall be cleaned and all materials re-racked or stacked on pallets as directed by the **COMPANY** material Representative.
- n. The **CONTRACTOR** shall be responsible for maintaining the designated material yard utilized for this project. The **CONTRACTOR** will provide any rock to the sites to stabilize the area. In addition, the **CONTRACTOR** shall be responsible for keeping the yards clean and shall not dispose any wastes on site without **COMPANY** approval. All such WORK will be at the **CONTRACTOR'S** expense.
- o. The **CONTRACTOR** shall designate an individual responsible for receipt of **COMPANY** materials and issuance to the **CONTRACTOR'S** force. The **CONTRACTOR** is reminded that weather sensitive equipment must be adequately sheltered from the elements (i.e., storage shed, trailer, etc.) to the satisfaction of the **COMPANY**. The **CONTRACTOR** shall supply equipment for off-loading all material at the storage yard.
- p. Tagging areas shall be acquired by the **CONTRACTOR** at the **CONTRACTOR'S** expense. Site areas shall be subject to **COMPANY** approval. In addition, the **CONTRACTOR** shall provide adequate time and sufficient information to the **COMPANY** in order for the **COMPANY** at the **COMPANY'S** expense, to provide the necessary archaeological and environmental clearances.
- q. Estimated Schedule of Delivery Dates
 - A. A schedule of delivery dates will be submitted to the successful bidder.

33. MATERIAL AND EQUIPMENT SUPPLIED BY THE CONTRACTOR

- a. The **CONTRACTOR** shall supply all material, equipment and supplies necessary for completion of the WORK in accordance with the DRAWINGS and

SPECIFICATIONS with the exception of material listed “Material and Equipment Supplied by the **COMPANY**”

34. FIELD OFFICE FACILITIES

- a. The **CONTRACTOR** shall provide, in addition to its own needs and at no additional cost to the **COMPANY**, temporary facilities detailed in Specification 015000 – Temporary Facilities for the use of the **COMPANY** and INSPECTION staff. The accommodation is to be provided complete with normal utilities (heating, air conditioning, light, power, and phone/ internet. It is to be secure and located in close proximity to the **CONTRACTOR’S** own field office complexes. Office layouts and telephone locations shall be approved by the **COMPANY** prior to installation.
- b. All equipment, furnishings and accommodations shall be provided in good working order and shall be repaired and/or maintained by the **CONTRACTOR** as necessary. Upon completion, the **CONTRACTOR** shall be responsible for demobilization and clean-up of all field office facilities.
- c. Refer to Specification 015000 – Temporary Facilities and Controls for additional requirements.

DRAFT - NOT FOR CONSTRUCTION

SECTION 011000- SUMMARY

PART 1 - GENERAL

1.1 WORK COVERED BY CONTRACT DOCUMENTS

- A. Project Identification: Project consists of Vermont Gas Systems - Addison Natural Gas Project.
 - 1. Project Location: Chittenden County and Addison County Vermont.
 - 2. Owner: Vermont Gas Systems, Inc., 85 Swift Street, South Burlington 05403
- B. Engineer Identification: The Contract Documents, dated October, 2013 were prepared for the Project by CHA, III Winners Circle, Albany, NY 12205.
- C. Construction Manager: To Be Determined

1.2 CONTRACTS

- A. The Project will be constructed under multiple contracts. Multiple contracts are separate contracts, representing significant construction activities, between Owner and separate contractors. Each contract is performed concurrently and coordinated closely with the construction activities performed on the Transmission Mainline Project. Cooperate fully with separate contractors so work on those contracts may be carried out smoothly, without interfering with or delaying work, under this or the separate Contracts.
- B. Contracts for the Vermont Gas Systems Addison Natural Gas Project include the following:
 - 1. Vermont Gas Systems Addison Natural Gas Project – Horizontal Directional Drill Design/Build (Awarded to Engineers Construction Inc. 98 Engineers Drive, Williston, VT 05495 Contact Tom Boyer 802-863-6389)
 - 2. Vermont Gas Systems Addison Natural Gas Project – Transmission Mainline
 - 3. Vermont Gas Systems Addison Natural Gas Project – Meter and Regulation Stations
 - 4. Vermont Gas Systems Addison Natural Gas Project – Distribution Mains
- C. The project consists of the following principal components:
 - 1. Approximately 42 miles + of new 12-inch transmission pipeline, extending from an existing gas mainline along Severance Road in Colchester, Vermont, to Route 7 in Middlebury, Vermont (the "Transmission Mainline").The transmission mainline will be contained as shown on the drawings, but generally, within a 50' wide permanent easement, with 25' temporary work space and additional temporary workspace easements.
 - 2. Launcher Site: The transmission mainline will interconnect with an existing pipeline in Colchester, VT, ("Colchester Launcher"). The Colchester Launcher is located on line list number (LLN) 1.03 (681 Severance Road, Colchester, VT), approximately 700 feet north of Severance Road, parallel to an existing gas mainline. The launcher will be contained on an easement having dimensions of 110 feet by 135 feet.

3. Three new distribution meter and regulating stations (Under Separate Contract):
 - a. Williston Station: Located on the south side of Route 2 (Williston Road) approximately 850' east of the Williston Road and Talcott Road intersection, in Williston.
 - b. Plank Road Station: Located on the south side of Plank Road approximately 1,050 feet west of the Plank Road and North Street intersection, in New Haven.
 - c. Middlebury Station: Located on the west side of Route 7 approximately 2,600 feet north of the Route 7 and Exchange Street intersection. It is also the terminus of the transmission mainline.
4. Meter and regulating stations will be located on parcels that are owned by Vermont Gas Systems. The Colchester tie-in and launch site will be located on property where Vermont Gas Systems will acquire an easement.
5. Construction of mainline valve sites, including driveways and access roads, fencing, electrical and communications services. This includes mainline valves located within the fence limits of the meter and regulation stations.
6. Transmission main-line valves: To be fabricated, hydrostatically tested and installed after mainline hydrotest.
7. Three distribution main pipelines (Under Separate Contract):
 - a. Vergennes Distribution Mainline: Approximately 3.7 miles of new 6-inch distribution mainline from the proposed Plank Road Station, westward along Plank Road to within two hundred feet of the Route 7 Plank Road intersection;
 - b. Middlebury Distribution Mainline: Approximately 1.3 miles of new 6-inch distribution main from the proposed Middlebury Station, south along Route 7, and thence south-westerly along Exchange Street to the approximate southern extents of the Agrimark, Inc. property line (869 Exchange St, Middlebury, VT). This is also the terminus of the project.
 - c. Middlebury Distribution Network: Approximately 5.1 miles of new 6-inch, 4-inch and 2-inch distribution network piping in Middlebury.

1.3 WORK UNDER THE TRANSMISSION MAINLINE CONTRACT

- A. The WORK under the Vermont Gas Systems Addison Natural Gas Project – Transmission Mainline consists of the following:

1. The Alignment as indicated on the project drawings and as generally described below:

- a. NORTHERN SEGMENT (Route-289 Corridor)

- 1) The project commences at the Colchester Launcher site, runs north 0.1 miles to northerly side of the un-built Circumferential Highway (CCCH, CIRC, Route 289) right-of-way. The pipeline follows the CCCH right-of-way in an easterly direction for approximately 2.1 miles crossing Mill Pond Road (STA 24+50), VELCO's K-22 transmission line (STA 70+00), Indian Brook (STA 80+00), and Colchester Road (Route 2A,

STA 110+00), ((See Crossings Table 1 attached for Stream, HDD, Utility and Road Crossing details) (Stations therein are approximate but relative, subject to localized equalization station adjustments)).

- 2) The alignment continues easterly along the CCCH right-of-way, for approximately 2.0 miles, to Upper Main Street (Route 15) (STA 215+00), crossing VELCO's transmission lines (STA 159+00) and Indian Brook (STA 192+00).
- 3) The alignment continues in a easterly direction along the northern extents of the built portion CCCH right-of-way, for approximately 0.5 miles, to and crossing Essex Way (STA 240+00).
- 4) The alignment continues to follow the CCCH right-of-way in a southeasterly direction for approximately 2.1 miles where it exits the CCCH right-of-way and jogs east then south lining up for the HDD under Route 117 (STA 357+00) and the Winooski River (STA 361+50); crossing Alder Brook three times along the way, (STA 266+25), (STA 324+00), and (STA 349+00), a Champlain Water District easement (STA 328+25), and a GMP electric easement (STA 328+75).
- 5) After the HDD crossing of the Winooski River, the alignment continues westerly along the New England Central Railroad right-of-way for 0.3 miles, crossing the RR at STA 373+00 and an un-built portion of the CCCH (STA 383+00), before it turns southwest and travels up between the Burlington Transfer Station and Chittenden Solid Waste District transfer station and intersects Redmond Road.
- 6) The alignment follows Redmond Road south southwest along its eastern side of the road ROW for approximately 1.4 miles to Mountain View Road (STA 474+00), crossing another portion of the CCCH right-of-way (Redmond Road Collector). and continues east along Mountain View Road, for approximately 0.1 miles, where it crosses Mountain View Road (STA 481+50), and reenters the CCCH right-of-way, proceeding south for approximately 1.2 miles; crossing Allen Brook (STA 546+75), and US Route 2 (Williston Road, STA 549+00), and connects to the Williston M&R Station on the south side of US Route 2.
- 7) The alignment continues in a south southwest direction to I-89, parallels the I-89 corridor for approximately 0.7 miles, and then crosses I-89 (STA 598+00) via a HDD, surfacing on the south side of Hurricane Lane, where it turns west and runs along the shoulder of Hurricane Lane 0.2 miles to the western side of the VELCO transmission line corridor.

b. MID SEGMENT (VELCO Corridor)

- 1) The alignment generally follows the VELCO corridor (VELCO) in a southerly direction for the next 2.3 miles to Lincoln Road. Paralleling VELCO, 0.5 miles from Hurricane Lane the pipeline cuts west to Route 2A (St George Road), parallels the same for 0.2 miles before crossing Route 2A (STA 656+00) and VELCO (STA 661+00) back to the western edge of VELCO (STA 662+50), where the pipeline resumes paralleling VELCO for the next mile before crossing back over VELCO (STA 711+50) and going around the VELCO Substation off Route 2A.

- 2) The alignment runs the eastern edge of VELCO after rounding the substation and continues south for approximately 0.6 miles, crossing Sucker Brook (STA 728+00) and Lincoln Road (STA 756+00).
- 3) The alignment turns off VELCO after crossing Lincoln Rd (STA 763+00) and runs off the western edge of Route 2A for 0.7 miles, crossing Breezy Valley Drive (STA 788+00) and then turning back to the VELCO ROW. The pipeline crosses VELCO (STA 804+00) and proceeds to follow the western extent of VELCO south 0.9 miles, where it crosses back across VELCO (STA 855+00) to Route 2A again (STA 867+50).
- 4) The alignment follows the western side of Route 2A for approximately 0.4 miles, where it then crosses Route 2A at the intersection of Rocky Ridge Circle (STA 887+50) and follows the eastern side of Route 2A crossing Route 116 (STA 893+00) and VELCO (STA 895+50).
- 5) The pipeline then follows the western side of VELCO for another 1.3 miles crossing Hickory Place, a private road, (STA 948+00) before diverging from VELCO at STA 962+00 for a 1.0 mile stretch, crossing a tributary to the LaPlatte River, and Shelburne Falls Road (STA 1000+00), and reconnects back to the western side of VELCO (STA 1014+00).
- 6) The alignment then proceeds south, generally following VELCO's ROW for approximately 4.8 miles; crossing the LaPlatte River (STA1028+75), HDD; Charlotte Road (STA1046+50); Baldwin Road (STA 1114+50); Drinkwater Road (STA 1179+00), HDD; and Lewis Creek (STA 1207+00), HDD; continuing along VELCO until STA 1266+50, where it then diverts around a conservation area and intersects with Rotax Road (STA 1295+50).
- 7) After crossing Rotax Road, the pipeline meanders cross country for 1.4 miles in a southerly direction until it reconnects to the westerly side of VELCO, and runs therewith for approximately 1.8 miles, crossing Stillson Road, a private road, (STA 1378+50), Hollow Road (STA 1397+00), and Post Road, a private road, (STA 1424+50). After crossing Post Road, the pipeline diverges away from VELCO in a southwesterly direction crossing under "Monkton Swamp" (STA 1439+50—1468+75), HDD.
- 8) The alignment reconnects with VELCO on the west side of Monkton Swamp at Station 1484+50 and follows the western side of VELCO for approximately 1.0 miles to Old Stage Road, crossing Monkton Road (STA 1491+00), HDD; and an Archaeological Site, (STA 1508+25 – 1512+50), HDD; where it then proceeds along Old Stage Road until Station 1564+50, where the pipeline crosses Old Stage Road and VELCO (STA 1568+00).
- 9) The alignment then follows the western side of VELCO for approximately 2.8 miles, crossing Parks Hurlburt Road (STA 1588+25), Little Otter Creek (STA 1705+50) and Plank Road (STA 1711+00), HDD; and travelling to the Plank Road M&R Station (STA 1718+50).

- 10) The pipeline exits the Plank Road M&R Station and continues south following the western side of VELCO for approximately 2.3 miles, crossing Quarry Road (STA 1768+50) Route 17 (STA 1842+50), circumventing the New Haven Substation (STA 1852+00) and then paralleling GMP ROW until reaching Town Hill Road (STA 1882+00) in New Haven. The pipeline crosses VELCO at Town Hill Road and follows along the eastern side of VELCO for 0.6 miles before crossing back to the western side of VELCO (STA 1921+00).
- 11) The pipeline continues along the western side of VELCO 3.1 miles to River Road (STA 2088+00), crossing Hunt Road (STA 2012+00) and the New Haven River (STA 2077+00), HDD

c. SOUTHERN SEGMENT

- 1) The southern segment of the alignment follows the northern side of River Road, for approximately 0.8 miles, to the intersection of Route 7 and River Road, where it crosses Route 7 (STA 2127+50) to the northern side of Belden Road, and immediately crosses Belden Road (STA 2129+50) and parallels Route 7 on its western side, heading south for approximately 1.0 miles to the Middlebury M&R Station.

2. ADDITIONAL WORK ITEMS

- a. The Transmission Mainline Contractor is responsible for constructing and maintaining the Construction Laydown Yards identified on plans ANGP-T-G-022 & 023, in accordance with Section 015000 Temporary Facilities and Controls, and as described below. The Owner/Engineer will require a Construction Trailer adjacent to any location the Mainline Contractor sets up facilities for their own use.
 - 1) Williston Pipe Yard: The entire scope of the Plank Road Pipe Yard is included in the Transmission Contract and is the responsibility of the selected contractor.
 - 2) Plank Road Pipe Yard: The entire scope of the Plank Road Pipe Yard is included in the Transmission Contract and is the responsibility of the selected contractor.
- b. The Transmission Mainline Contractor is responsible for constructing the Mainline Valve Sites. Materials furnished by owner are noted in this section. Required materials not provided by Owner, for a complete installation of the Mainline Valve Site will be the responsibility of the Contractor. Mainline valves within the fence limits of Meter and Regulation Stations are a responsibility of the Transmission Contractor. Coordination and scheduling between the Transmission Contractor and M&R Contractor for mainline valve installations is a requirement of this contract.
- c. The Transmission Mainline Contractor will be required to construct and utilize, as identified in the permits, wash stations for the removal of mud and vegetation on mats and equipment, before using mats or engaging equipment in activities within wetland areas.
- d. The Transmission Mainline Contractor shall install the 8-inch distribution casing, and all necessary appurtenances, at the New England Central Railroad crossing in Colchester (Approximately Sta. 112+71 to 113+88)

- e. The Transmission Mainline Contractor will be required to comply with all of the requirements and conditions of Permits secured, permit applications submitted, applicable additional information provided with this contract and Memorandum of Understandings agreed to by Vermont Gas Systems for the Addison Natural Gas Project.
- f. Colchester Launcher and Tie-In Site: As described in Section 1.2.C.
- g. Meter and Regulation (M&R) Station Access Roads: The civil/site construction of the M&R Station access roads is a responsibility of the Transmission Contractor. Coordination and scheduling between the Transmission Contractor and M&R Contractor for complete M&R station installations is a requirement of this contract. The Transmission Contractor access road limits of work shall be from the existing roads to the fence line of the M&R stations. The scope shall include all required stormwater and erosion prevention/sediment control measures. The scope shall include, but not be limited to, all earthwork, temporary access, drainage, subbase preparation, finished surfaces, and site restoration (within the defined limits of work).
- h. Any additional work items noted, shown, or indicated on the Project Drawings for a complete installation of the 12-inch transmission pipeline.

1.4 USE OF PREMISES

- A. General: Each Contractor shall have full use of premises for construction operations, including use of Project site, during construction period. Each Contractor's use of premises is limited only by Owner's right to perform work or to retain other contractors on portions of Project.
- B. The Owner has obtained necessary easements for the Project. The list of Property Owner's is included herein at the end of this Section. The Contractor shall be responsible for complying with all terms, requirements, and conditions of these easements.

1.5 OWNER-FURNISHED PRODUCTS

- A. Owner will furnish the following listed products. Contractor shall be responsible for transportation, protection, installation, testing and commissioning, as well as labor and equipment necessary for a complete installation.
 - 1. 12-inch transmission piping, fittings, valves, and appurtenances
 - 2. Mainline Valves, piping, fittings, actuators and appurtenances - 2-inches and greater in nominal size.
 - 3. 2,300 timber mats (4'x16'), any additional mats required for the complete installation of all contract components shall be furnished, installed, removed and disposed of (if necessary) by the Contractor.
 - 4. Items indicated as by owner on project plans.
- B. The Contractor shall include providing support systems to receive Owner's equipment and furnished products.

1. Contractor shall arrange and pay for delivery of Owner-furnished items according to Contractor's Construction Schedule. The haul route for delivery is included in Section "Maintenance and Protection of Traffic".
2. Contractor is responsible for receiving at the Owner's stockyard, loading, transporting, unloading, and handling Owner-furnished items at Project site.
3. After delivery, Owner will inspect delivered items for damage. Contractor shall be present for and assist in Owner's inspection.
4. If Owner-furnished items are damaged, defective, or missing, Owner will arrange for replacement.
5. Contractor is responsible for protecting Owner-furnished items from damage during storage and handling, including damage from exposure to the elements.
6. If Owner-furnished items are damaged as a result of Contractor's operations, Contractor shall repair or replace them.

1.6 SPECIFICATION FORMATS AND CONVENTIONS

- A. Specification Format: The Specifications are generally organized into Divisions and Sections using the 48-division format and CSI/CSC's "MasterFormat" numbering system.
 1. Section Identification: The Specifications use section numbers and titles to help cross-referencing in the Contract Documents. Sections in the Project Manual are in numeric sequence; however, the sequence is incomplete. Consult the table of contents at the beginning of the Project Manual to determine numbers and names of sections in the Contract Documents.
- B. Specification Content: The Specifications use certain conventions for the style of language and the intended meaning of certain terms, words, and phrases when used in particular situations. These conventions are as follows:
 1. Abbreviated Language: Language used in the Specifications and other Contract Documents is abbreviated. Words and meanings shall be interpreted as appropriate. Words implied, but not stated, shall be inferred as the sense requires. Singular words shall be interpreted as plural, and plural words shall be interpreted as singular where applicable as the context of the Contract Documents indicates.
 2. Imperative mood and streamlined language are generally used in the Specifications. Requirements expressed in the imperative mood are to be performed by Contractor. Occasionally, the indicative or subjunctive mood may be used in the Section Text for clarity to describe responsibilities that must be fulfilled indirectly by Contractor or by others when so noted.
 - a. The words "shall," "shall be," or "shall comply with," depending on the context, are implied where a colon (:) is used within a sentence or phrase.

END OF SECTION

SECTION 012300 - ALTERNATES

PART 1 - GENERAL

1.1 SUMMARY

- A. This Section includes administrative and procedural requirements for alternates.

1.2 DEFINITIONS

- A. Alternate: An amount proposed by bidders and stated on the Bid Form for certain work defined in the Bidding Requirements that may be added to or deducted from the Base Bid amount if Owner decides to accept a corresponding change either in the amount of construction to be completed or in the products, materials, equipment, systems, or installation methods described in the Contract Documents.
1. The cost or credit for each alternate is the net addition to or deduction from the Contract Sum to incorporate alternate into the Work. No other adjustments are made to the Contract Sum.

1.3 PROCEDURES

- A. Coordination: Modify or adjust affected adjacent work as necessary to completely integrate work of the alternate into Project.
1. Include as part of each alternate, miscellaneous devices, accessory objects, and similar items incidental to or required for a complete installation whether or not indicated as part of alternate.
- B. Notification: Immediately following award of the Contract, notify each party involved, in writing, of the status of each alternate. Indicate if alternates have been accepted, rejected, or deferred for later consideration. Include a complete description of negotiated modifications to alternates.
- C. Execute accepted alternates under the same conditions as other work of the Contract.
- D. Schedule: A Schedule of Alternates is included at the end of this Section. Specification Sections referenced in schedule contain requirements for materials necessary to achieve the work described under each alternate.

PART 2 - PRODUCTS (Not Used)

PART 3 - EXECUTION

3.1 SCHEDULE OF ALTERNATES

- A. Alternate No. 1 – Project Rock/Ledge Removal (INCLUDED)
1. Alternate #1 shall be a Lump Sum added cost to the overall project Lump Sum amount. If accepted by Owner, Contractor shall assume all responsibility for any and all required rock removal and disposal (if necessary) over the entire length of the project. *Supply and installation of pipeline pillows and rock shield shall be included in this price.* The Owner reserves the right to accept or reject this Alternate Price. If the Owner rejects the Alternate Price, but accepts the overall Project Lump Sum amount, rock removal shall be

paid for on a unit cost basis with the limits defined by the Rock Removal technical specification.

B. Alternate No. 2 – HDD Support (INCLUDED)

1. Work included under this Alternate involves providing support of the HDD Contractors operations. If accepted by the Owner, the Contractor shall provide services to the Owner's HDD Contractor that are necessary for the completion of the *sixteen (16)* HDD's included in the Vermont Gas Systems Addison Natural Gas Project – Horizontal Directional Drill Design/Build scope of work. HDD sections are defined on the alignment sheets with start and stop stations. The Contractor will provide support to the HDD Contractor to the extent identified below:
 - a. Receive and offload pipe deliveries for the HDD sections in Swanton, VT (44*54'13.62" / 73*6'28.17"). Load and transport pipe from Swanton to HDD locations in accordance with HDD Contractor's scheduling needs and project permitting requirements. Unload, handle and string pipe at the HDD site.
 - b. Clear and Grade Site;
 - c. Install timber mats as needed;
 - d. Install temporary access roads;
 - e. Align, weld, and coat HDD pull back pipe field joints;
 - f. Place HDD pipe pull back section on rollers;
 - g. Install Hydrostatic Test Manifolds on HDD pipe pull back section;
 - h. Fill HDD pipe pull back section with water;
 - i. Complete successful 4hr Hydrostatic Test of HDD pipe pull back section (pre and post-installation);
 - j. Dewater HDD pipe pull back section;
 - k. Provide Holiday Detector to inspect HDD pipe pull back section for coating Holidays during pipe pull back operations;
 - l. Repair coating Holidays during HDD pipe pull back operations;
 - m. Provide all necessary equipment, operators, and labors, to assist HDD Contractor with The installation of HDD pipe pull back section;
 - n. Provide all necessary equipment, operators, labor, and materials to run a 95% ID aluminum sizing plate through HDD pipe pull back section;
 - o. Coordinate final tie-ins of HDD pipe pull back section with Mainline Pipeline Contractor;
 - p. Remove timber mats from site;
 - q. Restore site to finish grade;
 - r. Complete clean up and final restoration
2. Provide Schedule of values that adequately breaks down the cost adder in a manner that allows Owner to evaluate pricing. A cost breakdown for each HDD is requested.
3. Additional HDD operations are being contemplated, the cost breakdown will be used as a basis for including additional scope.

NOTE: The HDD Contractor is responsible for the containment, removal, and disposal of all inadvertent returns of any drilling fluids.

C. Alternate No. 3 – NGA OQ Alternative (EXCLUDED)

1. Alternate #3 shall be a Lump Sum deducted cost to the overall project Lump Sum amount. If accepted by the Owner, the Contractor will provide an acceptable alternative to the specification requirement as described in the Instructions to Bidders, Item 21.1 Operator Qualification Requirements, whereby the Contractor will meet the requirements for any covered task performed by the Northeast Gas Association (NGA). Include with the deduct price, the name of the proposed OQ service provider.

- D. Alternate No. 4 – Jack and Bore Alternative (Sta. 109+29 to 113+96) (INCLUDED)
1. Alternate #4 shall include all required work, as shown on the plans, for a complete installation of all piping, cases, appurtenances and all other associated components from Sta. 109+29 to 113+96. The Transmission Contractor has submitted an acceptable proposal of directional drilling (HDD) the proposed work. The HDD work shall be completed by the existing HDD Contractor (Engineers Construction, Inc – Williston, Vermont) and be supported, as described in Alternate 2 above, by the Transmission Contractor. The price included in this contract shall be for HDD Support only. The HDD Contract will be amended as necessary to include all components required for a complete installation of work between Sta. 109+29 and 113+96. The HDD design/construction shall meet specifications for Genesee and Wyoming Railway Crossings (New England Central Railroad locations) – refer to documents attached to Addendum 2.
- E. Alternate No. 5 – Jack and Bore Alternative (Sta. 372+36 to 373+85) (INCLUDED)
1. Alternate #4 shall include all required work, as shown on the plans, for a complete installation of all piping, cases, appurtenances and all other associated components from Sta. 372+36 to 373+85. The crossing is currently shown as a horizontal crossing with 11.1’ of cover below the tracks – this may be modified and the casing/carrier installed with a vertical angle, as long as a minimum separation from the tracks to the top of casing is 6.5’. Contractors may submit an alternate installation solution without a casing – indicate the installation method as well as the cost deduct (if applicable) of this Alternate with the bid submission. The alternate installation solution shall meet specifications for Genesee and Wyoming Railway Crossings (New England Central Railroad locations) – refer to attached documents.

END OF SECTION

DRAFT - NOT FOR CONSTRUCTION

SECTION 012600- CONTRACT MODIFICATION PROCEDURES

PART 1 - GENERAL

1.1 SUMMARY

- A. This Section specifies administrative and procedural requirements for handling and processing Contract modifications.

1.2 MINOR CHANGES IN THE WORK

- A. Owner's Consultant will issue through Construction Manager supplemental instructions authorizing Minor Changes in the Work, not involving adjustment to the Contract Sum or the Contract Time.

1.3 PROPOSAL REQUESTS

- A. Owner-Initiated Proposal Requests: Construction Manager will issue a detailed description of proposed changes in the Work that may require adjustment to the Contract Sum or the Contract Time. If necessary, the description will include supplemental or revised Drawings and Specifications.

1. Proposal Requests issued by Construction Manager are for information only. Do not consider them instructions either to stop work in progress or to execute the proposed change.
2. Within time specified in Proposal Request after receipt of Proposal Request, submit a quotation estimating cost adjustments to the Contract Sum and the Contract Time necessary to execute the change.
 - a. Include a list of quantities of products required or eliminated and unit costs, with total amount of purchases and credits to be made. If requested, furnish survey data to substantiate quantities.
 - b. Indicate applicable taxes, delivery charges, equipment rental, and amounts of trade discounts.
 - c. Include an updated Contractor's Construction Schedule that indicates the effect of the change, including, but not limited to, changes in activity duration, start and finish times, and activity relationship. Use available total float before requesting an extension of the Contract Time.

- B. Contractor-Initiated Proposals: If latent or unforeseen conditions require modifications to the Contract, Contractor may propose changes by submitting a request for a change to Construction Manager.

1. Include a statement outlining reasons for the change and the effect of the change on the Work. Provide a complete description of the proposed change. Indicate the effect of the proposed change on the Contract Sum and the Contract Time.

2. Include a list of quantities of products required or eliminated and unit costs, with total amount of purchases and credits to be made. If requested, furnish survey data to substantiate quantities.
 3. Indicate applicable taxes, delivery charges, equipment rental, and amounts of trade discounts.
 4. Include an updated Contractor's Construction Schedule that indicates the effect of the change, including, but not limited to, changes in activity duration, start and finish times, and activity relationship. Use available total float before requesting an extension of the Contract Time.
 5. Comply with requirements in Division 1 Section "Product Requirements" if the proposed change requires substitution of one product or system for product or system specified.
- C. Proposal Request Form: For Change Order proposals use CSI Change Order Request (proposal format).

1.4 CHANGE ORDER PROCEDURES

- A. On Owner's approval of a Proposal Request, Construction Manager will issue a Change Order for signatures of Owner and Contractor on form.

1.5 WORK CHANGE DIRECTIVE

- A. Work Change Directive: Construction Manager may issue a Work Change Directive. Work Change Directive instructs Contractor to proceed with a change in the Work, for subsequent inclusion in a Change Order.
1. Work Change Directive contains a complete description of change in the Work. It also designates method to be followed to determine change in the Contract Sum or the Contract Time.
- B. Documentation: Maintain detailed records on a time and material basis of work required by the Work Change Directive.
1. After completion of change, submit an itemized account and supporting data necessary to substantiate cost and time adjustments to the Contract.

PART 2 - PRODUCTS (Not Used)

PART 3 - EXECUTION (Not Used)

END OF SECTION

SECTION 012900- PAYMENT PROCEDURES

PART 1 - GENERAL

1.1 SUMMARY

- A. This Section specifies administrative and procedural requirements necessary to prepare and process Applications for Payment.

1.2 DEFINITIONS

- A. Schedule of Values: A statement furnished by Contractor allocating portions of the Contract Sum to various portions of the Work and used as the basis for reviewing Contractor's Applications for Payment.

1.3 SCHEDULE OF VALUES

- A. Coordination: Coordinate preparation of the Schedule of Values with preparation of Contractor's Construction Schedule.

- 1. Correlate line items in the Schedule of Values with other required administrative forms and schedules, including the following:
 - a. Contractor's progress schedule.
 - b. Application for Payment form.
 - c. List of subcontractors.
 - d. List of products.
 - e. List of principal suppliers and fabricators.
 - f. Schedule of submittals.
- 2. Submit the Schedule of Values to Owner's Consultant through Construction Manager at earliest possible date but no later than 21 days before the date scheduled for submittal of initial Applications for Payment.
- 3. Subschedules: Where the Work is separated into phases requiring separately phased payments, provide subschedules showing values correlated with each phase of payment.

- B. Format and Content: Use the Project Manual table of contents as a guide to establish line items for the Schedule of Values. Provide at least one line item for each Specification Section.

- 1. Identification: Include the following Project identification on the Schedule of Values:
 - a. Project name and location.
 - b. Name of Engineer.
 - c. Project number.
 - d. Contractor's name and address.
 - e. Date of submittal.
- 2. Arrange the Schedule of Values in tabular form with separate columns to indicate the following for each item listed:
 - a. Generic Name
 - b. Related Specification Section or Division.

- c. Description of the Work.
 - d. Name of subcontractor.
 - e. Name of manufacturer or fabricator.
 - f. Name of supplier.
 - g. Change Orders (numbers) that affect value.
 - h. Dollar value.
- 1) Percentage of the Contract Sum to nearest one-hundredth percent, adjusted to total 100 percent.
- 3. Provide a breakdown of the Contract Sum in enough detail to facilitate continued evaluation of Applications for Payment and progress reports. Coordinate with the Project Manual table of contents. Provide several line items for principal subcontract amounts, where appropriate.
 - 4. Round amounts to nearest whole dollar; total shall equal the Contract Sum.
 - 5. Provide a separate line item in the Schedule of Values for each part of the Work where Applications for Payment may include materials or equipment purchased or fabricated and stored, but not yet installed.
 - a. Differentiate between items stored on-site and items stored off-site. Include evidence of insurance or bonded warehousing if required.
 - 6. Provide separate line items in the Schedule of Values for initial cost of materials, for each subsequent stage of completion, and for total installed value of that part of the Work.
 - 7. Each item in the Schedule of Values and Applications for Payment shall be complete. Include total cost and proportionate share of general overhead and profit for each item.
 - a. Temporary facilities and other major cost items that are not direct cost of actual work-in-place may be shown either as separate line items in the Schedule of Values or distributed as general overhead expense, at Contractor's option.
 - 8. Schedule Updating: Update and resubmit the Schedule of Values before the next Applications for Payment when Change Orders or Construction Change Directives result in a change in the Contract Sum.

1.4 APPLICATIONS FOR PAYMENT

- A. Each Application for Payment shall be consistent with previous applications and payments as certified by Owner's Consultant and Construction Manager and paid for by Owner.
 - 1. Initial Application for Payment, Application for Payment at time of Substantial Completion, and final Application for Payment involve additional requirements.
- B. Payment Application Times: The date for each progress payment is indicated in the Agreement between Owner and Contractor. The period of construction Work covered by each Application for Payment is the period indicated in the Agreement.
- C. Payment Application Forms: Use AIA Document G702 and AIA Document G703 Continuation Sheets for Applications for Payment or use forms provided by Owner for Applications for Payment. Sample copies will be provided, if requested.

- D. Application Preparation: Complete every entry on form. Notarize and execute by a person authorized to sign legal documents on behalf of Contractor. Construction Manager will return incomplete applications without action.
1. Entries shall match data on the Schedule of Values and Contractor's Construction Schedule. Use updated schedules if revisions were made.
 2. Include amounts of Change Orders and Construction Change Directives issued before last day of construction period covered by application.
- E. Transmittal: Submit 3 signed and notarized original copies of each Application for Payment to Construction Manager by a method ensuring receipt within 24 hours. One copy shall include waivers of lien and similar attachments if required.
1. Transmit each copy with a transmittal form listing attachments and recording appropriate information about application.
- F. Waivers of Mechanic's Lien: With every other Application for Payment (once monthly), submit waivers of mechanic's liens from subcontractors, sub-subcontractors, and suppliers for construction period covered by the previous application. This requirement only applies for contractual values of greater than \$50,000.
1. Submit partial waivers on each item for amount requested, before deduction for retainage, on each item.
 2. When an application shows completion of an item, submit final or full waivers.
 3. Owner reserves the right to designate which entities involved in the Work must submit waivers.
 4. Waiver Delays: Submit each Application for Payment with Contractor's waiver of mechanic's lien for construction period covered by the application.
 - a. Submit final Application for Payment with or preceded by final waivers from every entity involved with performance of the Work covered by the application who is lawfully entitled to a lien.
 5. Waiver Forms: Submit waivers of lien on forms, executed in a manner acceptable to Owner.
- G. Initial Application for Payment: Administrative actions and submittals that must precede or coincide with submittal of first Application for Payment include the following:
1. List of subcontractors.
 2. Schedule of Values.
 3. Contractor's Construction Schedule (preliminary if not final).
 4. Products list.
 5. Submittals Schedule (preliminary if not final).
 6. List of Contractor's staff assignments.
 7. List of Contractor's principal consultants.
 8. Copies of permits, if required to be obtained by Contractor.
 9. Initial progress report.
 10. Report of preconstruction conference.
 11. Certificates of insurance and insurance policies.

- H. Application for Payment at Substantial Completion: After issuing the Certificate of Substantial Completion, submit an Application for Payment showing 100 percent completion for portion of the Work claimed as substantially complete.
1. Include documentation supporting claim that the Work is substantially complete and a statement showing an accounting of changes to the Contract Sum.
 2. This application shall reflect Certificates of Partial Substantial Completion issued previously for designated portions of the Work.
- I. Final Payment Application: Submit final Application for Payment with releases and supporting documentation not previously submitted and accepted, including, but not limited, to the following:
1. Evidence of completion of Project closeout requirements.
 2. Insurance certificates for products and completed operations where required and proof that taxes, fees, and similar obligations were paid.
 3. Updated final statement, accounting for final changes to the Contract Sum.
 4. AIA Document G706 "Contractor's Affidavit of Payment of Debts and Claims."
 5. AIA Document G706A "Contractor's Affidavit of Release of Liens."
 6. AIA Document G707 "Consent of Surety to Final Payment."
 7. Evidence that claims have been settled.
 8. Final meter readings for utilities, a measured record of stored fuel, and similar data as of date of Substantial Completion or when Owner took possession of and assumed responsibility for corresponding elements of the Work.
 9. Final, liquidated damages settlement statement.

PART 2 - PRODUCTS (Not Used)

PART 3 - EXECUTION (Not Used)

END OF SECTION

SECTION 013000- PROJECT MANAGEMENT AND COORDINATION

PART 1 - GENERAL

1.1 SUMMARY

- A. This Section includes administrative provisions for coordinating construction operations on Project including, but not limited to, the following:
1. Coordination.
 2. Submittals.
 3. Administrative and supervisory personnel.
 4. Project meetings.
 5. General installation provisions.
 6. Cleaning and protection.
- B. Where applicable, each prime Contractor shall participate in these coordination requirements, even though certain areas of responsibility are assigned to a specific prime Contractor.

1.2 COORDINATION

- A. Coordination: Coordinate construction activities included under various Sections of these Specifications to assure efficient and orderly installation of each part of the Work. Coordinate construction operations included under different Sections of these Specifications that are dependent upon each other for proper installation, connection, and operation.
- B. Coordination: Each prime contractor shall cooperate with Owner's, coordinate construction activities to assure efficient and orderly installation of each part of the Work.
1. Where installation of one part of the Work is dependent on installation of other components, either before or after its own installation, cooperate with scheduled construction activities in the sequence required to obtain the best results.
 2. Where availability of space is limited, coordinate installation of different components to assure maximum accessibility for required maintenance, service and repair.
 3. Make adequate provisions to accommodate items scheduled for later installation.
 4. Coordinate construction activities with public and private utilities.
 - a. Notify Dig Safe® a minimum of 48 hours prior to excavation or blasting.
 - b. Notify the Owner, Construction Manager, and the Owner's Representative of any utility locations encountered which conflict with the work. Coordinate with the Owner and Utility Company in the protection, removal, relocation or replacement of conflicting utility locations.
- C. Where necessary, prepare memoranda for distribution to each party involved outlining special procedures required for coordination. Include such items as required notices, reports, and attendance at meetings.
1. Prepare similar memoranda for the Owner and separate Contractors where coordination of their Work is required.

- D. Administrative Procedures: Coordinate scheduling and timing of required administrative procedures with other construction activities and activities of other contractors to avoid conflicts and to ensure orderly progress of the Work. Such administrative activities include, but are not limited to, the following:
1. Preparation of Contractor's Construction Schedule.
 2. Preparation of the Schedule of Values.
 3. Installation and removal of temporary facilities and controls.
 4. Delivery and processing of submittals.
 5. Progress meetings.
 6. Pre-installation conferences.
 7. Project closeout activities.
- E. Conservation: Coordinate construction activities to ensure that operations are carried out with consideration given to conservation of energy, water, and materials.
1. Salvage materials and equipment involved in performance of, but not actually incorporated into, the Work. Refer to other Sections for disposition of salvaged materials that are designated as Owner's property.

1.3 SUBMITTALS

- A. Coordination Drawings: Prepare and submit coordination Drawings where close and careful coordination is required for installation of products and materials fabricated off-site by separate entities, and where limited space availability necessitates maximum utilization of space for efficient installation of different components.
1. Show the interrelationship of components shown on separate Shop Drawings.
 2. Indicate required installation sequences.
 3. Comply with requirements contained in Section "Submittals Procedures."
- B. Staff Names: Within 15 days of starting construction operations, submit a list of principal staff assignments, including superintendent and other personnel in attendance at Project site. Identify individuals and their duties and responsibilities; list addresses and telephone numbers, including home and office telephone numbers. Provide names, addresses, and telephone numbers of individuals assigned as standbys in the absence of individuals assigned to Project.
1. Post copies of list in Project meeting room, in temporary field office, and by each temporary telephone.

1.4 PROJECT MEETINGS

- A. General: Schedule and conduct meetings and conferences at Project site, unless otherwise indicated.
1. Attendees: Inform participants and others involved, and individuals whose presence is required, of date and time of each meeting. Notify Construction Manager of scheduled meeting dates and times.
 2. Agenda: Prepare the meeting agenda. Distribute the agenda to all invited attendees.
 3. Minutes: Record significant discussions and agreements achieved. Distribute the meeting minutes to everyone concerned, including Owner and Owner's Representative, within 3 days of the meeting.

B. Preconstruction Conference: Schedule a preconstruction conference and organizational meeting at the Project site or other convenient site prior to commencement of construction activities. Conduct the meeting to review responsibilities and personnel assignments.

1. Attendees: Authorized representatives of Owner, the Owner's Consultants, and their consultants; the Contractor and its superintendent; major subcontractors; manufacturers; suppliers and other concerned parties shall each be represented at the conference. All participants at the conference shall be familiar with Project and authorized to conclude matters relating to the Work.

2. Agenda: Discuss items of significance that could affect progress, including the following:

- a. Tentative construction schedule.
- b. Phasing.
- c. Critical work sequencing.
- d. Designation of responsible personnel.
- e. Procedures for processing field decisions and Change Orders.
- f. Procedures for processing Applications for Payment.
- g. Distribution of the Contract Documents.
- h. Submittal procedures.
- i. Preparation of Record Documents.
- j. Use of the premises.
- k. Responsibility for temporary facilities and controls.
- l. Parking availability.
- m. Office, work, and storage areas.
- n. Equipment deliveries and priorities.
- o. Safety procedures.
- p. First aid.
- q. Security.
- r. Progress cleaning.
- s. Working hours.
- t. Housekeeping.
- u. Subcontractors.
- v. Preliminary Schedule of Shop Drawings and Samples.
- w. Co-ordination with other contractors.
- x. Insurance in Force.
- y. Contractor's Schedule of Values.

C. Progress Meetings: Conduct progress meetings at the Project Site at regularly scheduled intervals. Coordinate dates of meetings with preparation of payment requests.

1. Attendees: In addition to representatives of the Owner and Owner's Consultants, each contractor, subcontractor, supplier, and other entity concerned with current progress or involved in planning, coordination, or performance of future activities shall be represented at these meetings. All participants at the conference shall be familiar with Project and authorized to conclude matters relating to the Work.

2. Agenda: Review and correct or approve minutes of previous progress meeting. Review other items of significance that could affect progress. Include topics for discussion as appropriate to the current status of Project.

a. Contractor's Construction Schedule: Review progress since the last meeting. Determine whether each activity is on time, ahead of schedule, or behind schedule, in relation to Contractor's Construction Schedule. Determine how

construction behind schedule will be expedited; secure commitments from parties involved to do so. Discuss whether schedule revisions are required to ensure that current and subsequent activities will be completed within the Contract Time.

- b. Review present and future needs of each entity present, including the following:
 - 1) Interface requirements.
 - 2) Time.
 - 3) Sequence of operations.
 - 4) Status of submittals.
 - 5) Deliveries.
 - 6) Off-site fabrication.
 - 7) Access.
 - 8) Site utilization.
 - 9) Temporary facilities and controls.
 - 10) Work hours.
 - 11) Hazards and risks.
 - 12) Progress cleaning.
 - 13) Quality and work standards.
 - 14) Change Orders.
 - 15) Documentation of information for payment requests.
- 3. Reporting: No later than 3 days after each progress meeting date, distribute copies of minutes of the meeting to each party present and to parties who should have been present. Include a brief summary, in narrative form, of progress since the previous meeting and report.
 - a. Schedule Updating: Revise Contractor's Construction Schedule after each progress meeting where revisions to the schedule have been made or recognized. Issue the revised schedule concurrently with the report of each meeting.

PART 2 - PRODUCTS (Not Applicable)

PART 3 - EXECUTION

3.1 GENERAL INSTALLATION PROVISIONS

- A. Inspection of Conditions: Require the Installer of each major component to inspect both the substrate and conditions under which Work is to be performed. Do not proceed until unsatisfactory conditions have been corrected in an acceptable manner.
- B. Manufacturer's Instructions: Comply with manufacturer's installation instructions and recommendations, to the extent that those instructions and recommendations are more explicit or stringent than requirements contained in Contract Documents.
- C. Inspect materials or equipment immediately upon delivery and again prior to installation. Reject damaged and defective items.
- D. Provide attachment and connection devices and methods necessary for securing Work. Secure Work true to line and level. Allow for expansion and building movement.
- E. Recheck measurements and dimensions, before starting each installation.

- F. Install each component during weather conditions and Project status that will ensure the best possible results. Isolate each part of the completed construction from incompatible material as necessary to prevent deterioration.
- G. Coordinate temporary enclosures with required inspections and tests, to minimize the necessity of uncovering completed construction for that purpose.

3.2 CLEANING AND PROTECTION

- A. During handling and installation, clean and protect construction in progress and adjoining materials in place. Apply protective covering where required to ensure protection from damage or deterioration at Substantial Completion.
- B. Clean and maintain completed construction as frequently as necessary through the remainder of the construction period. Adjust and lubricate operable components to ensure operability without damaging effects.
- C. Limiting Exposures: Supervise construction activities to ensure that no part of the construction completed or in progress, is subject to harmful, dangerous, damaging, or otherwise deleterious exposure during the construction period. Where applicable, such exposures include, but are not limited to, the following:
 - 1. Excessive static or dynamic loading.
 - 2. Excessive internal or external pressures.
 - 3. Excessively high or low temperatures.
 - 4. Thermal shock.
 - 5. Excessively high or low humidity.
 - 6. Air contamination or pollution.
 - 7. Water or ice.
 - 8. Solvents.
 - 9. Chemicals.
 - 10. Light.
 - 11. Radiation.
 - 12. Puncture.
 - 13. Abrasion.
 - 14. Heavy traffic.
 - 15. Soiling, staining and corrosion.
 - 16. Combustion.
 - 17. Electrical current.
 - 18. Unusual wear or other misuse.
 - 19. Contact between incompatible materials.
 - 20. Destructive testing.
 - 21. Misalignment.
 - 22. Excessive weathering.
 - 23. Unprotected storage.
 - 24. Improper shipping or handling.
 - 25. Theft.
 - 26. Vandalism.

END OF SECTION

SECTION 013200- CONSTRUCTION PROGRESS DOCUMENTATION

PART 1 - GENERAL

1.1 SUMMARY

- A. This Section includes administrative and procedural requirements for documenting the progress of construction during performance of the Work, including the following:
1. Preliminary Construction Schedule.
 2. Contractor's Construction Schedule.
 3. Submittals Schedule.
 4. Daily construction reports.
 5. Material location reports.
 6. Field condition reports.
 7. Special reports.
 8. Construction photographs.

1.2 DEFINITIONS

- A. Activity: A discrete part of a project that can be identified for planning, scheduling, monitoring, and controlling the construction project. Activities included in a construction schedule consume time and resources.
1. Critical activities are activities on the critical path. They must start and finish on the planned early start and finish times.
 2. Predecessor activity is an activity that must be completed before a given activity can be started.
- B. CPM: Critical path method, which is a method of planning and scheduling a construction project where activities are arranged based on activity relationships. Network calculations determine when activities can be performed and the critical path of Project.
- C. Critical Path: The longest continuous chain of activities through the network schedule that establishes the minimum overall Project duration and contains no float.
- D. Event: The starting or ending point of an activity.
- E. Float: The measure of leeway in starting and completing an activity.
1. Float time is not for the exclusive use or benefit of either Owner or Contractor, but is a jointly owned, expiring Project resource available to both parties as needed to meet schedule milestones and Contract completion date.
 2. Free float is the amount of time an activity can be delayed without adversely affecting the early start of the following activity.
 3. Total float is the measure of leeway in starting or completing an activity without adversely affecting the planned Project completion date.
- F. Fragnet: A partial or fragmentary network that breaks down activities into smaller activities for greater detail.

- G. Major Area: A story of construction, a separate building, or a similar significant construction element.
- H. Milestone: A key or critical point in time for reference or measurement.
- I. Network Diagram: A graphic diagram of a network schedule, showing activities and activity relationships.

1.3 SUBMITTALS

- A. Qualification Data: For firms and persons specified in "Quality Assurance" Article to demonstrate their capabilities and experience. Include lists of completed projects with project names and addresses, names and addresses of architects and owners, and other information specified.
- B. Submittals Schedule: Submit 3 copies of schedule. Arrange the following information in a tabular format:
 - 1. Scheduled date for first submittal.
 - 2. Specification Section number and title.
 - 3. Submittal category (action or informational).
 - 4. Name of subcontractor.
 - 5. Description of the Work covered.
 - 6. Scheduled date for Engineer's and Construction Manager final release or approval.
- C. Preliminary Construction Schedule: Submit 2 printed copies; and one electronic copy. Preliminary Network Diagram: Submit 2 printed copies; one a single sheet of reproducible media, and one electronic copy; large enough to show entire network for entire construction period.
- D. Contractor's Construction Schedule: Submit 2 printed copies of initial schedule, one a reproducible print and one a blue- or black-line print, large enough to show entire schedule for entire construction period.
 - 1. Submit an electronic copy of schedule on CD or DVD. Include type of schedule (Initial or Updated) and date on label.
- E. CPM Reports: Concurrent with CPM schedule, submit 3 printed copies of each of the following computer-generated reports. Format for each activity in reports shall contain activity number, activity description, original duration, remaining duration, early start date, early finish date, late start date, late finish date, and total float.
 - 1. Activity Report: List of all activities sorted by activity number and then early start date, or actual start date if known.
 - 2. Logic Report: List of preceding and succeeding activities for all activities, sorted in ascending order by activity number and then early start date, or actual start date if known.
 - 3. Total Float Report: List of all activities sorted in ascending order of total float.
 - 4. Earnings Report: Compilation of Contractor's total earnings from commencement of the Work until most recent Application for Payment.
- F. Construction Photographs: Submit a digital photo of each view within 7 days of taking photographs.

1. Format: Digital JPG image with minimum resolution of 2584x1936 and image quality set to fine/high or better.
2. Identification: A photo-log shall be provided containing a record for each submitted photo with the following information:
 - a. File Name of Photo.
 - b. Name of Project.
 - c. Name and address of photographer.
 - d. Name of Engineer [and Construction Manager].
 - e. Name of Contractor.
 - f. Date photograph was taken.
 - g. Description of vantage point, indicating location, direction (by compass point), and elevation or story of construction.

Photo-logs may be scanned hard-copy forms, though digital formats such as MS Word, MS Excel or MS Access are preferred. If the delivery method for the photos is via an online file management system, photo-log records should be entered into that system provided it supports entering the above information.

3. Delivery: All photos and accompanying identification will be uploaded to the Project's Collaboration Website.

- G. Daily Construction Reports: Submit 2 copies at monthly intervals.
- H. Material Location Reports: Submit 2 copies at monthly intervals.
- I. Field Condition Reports: Submit 2 copies at time of discovery of differing conditions.
- J. Special Reports: Submit 2 copies at time of unusual event.

1.4 QUALITY ASSURANCE

- A. Scheduling Consultant Qualifications: An experienced specialist in CPM scheduling and reporting.

1.5 COORDINATION

- A. Coordinate preparation and processing of schedules and reports with performance of construction activities and with scheduling and reporting of separate contractors.
- B. Coordinate Contractor's Construction Schedule with the Schedule of Values, list of subcontracts, Submittals Schedule, progress reports, payment requests, and other required schedules and reports.
 1. Secure time commitments for performing critical elements of the Work from parties involved.
 2. Coordinate each construction activity in the network with other activities and schedule them in proper sequence.

- C. Auxiliary Services: Cooperate with photographer and provide auxiliary services requested, including access to Project site and use of temporary facilities including temporary lighting.

PART 2 - PRODUCTS

2.1 SUBMITTALS SCHEDULE

- A. Preparation: Submit a schedule of submittals, arranged in chronological order by dates required by construction schedule. Include time required for review, resubmittal, ordering, manufacturing, fabrication, and delivery when establishing dates.
 - 1. Coordinate Submittals Schedule with list of subcontracts, the Schedule of Values, and Contractor's Construction Schedule.
 - 2. Initial Submittal: Submit concurrently with preliminary network diagram. Include submittals required during the first 60 days of construction. List those required to maintain orderly progress of the Work and those required early because of long lead time for manufacture or fabrication.
 - a. At Contractor's option, show submittals on the Preliminary Construction Schedule, instead of tabulating them separately.
 - 3. Final Submittal: Submit concurrently with the first complete submittal of Contractor's Construction Schedule.

2.2 CONTRACTOR'S CONSTRUCTION SCHEDULE, GENERAL

- A. Procedures: Comply with procedures contained in AGC's "Construction Planning & Scheduling."
- B. Time Frame: Extend schedule from date established for the Notice of Award.
 - 1. Contract completion date shall not be changed by submission of a schedule that shows an early completion date, unless specifically authorized by Change Order.
- C. Activities: Treat each separate area as a separate numbered activity for each principal element of the Work. Comply with the following:
 - 1. Activity Duration: Define activities so no activity is longer than 20 days, unless specifically allowed by Construction Manager.
 - 2. Procurement Activities: Include procurement process activities for long lead items and major items, requiring a cycle of more than 60 days, as separate activities in schedule. Procurement cycle activities include, but are not limited to, submittals, approvals, purchasing, fabrication, and delivery.
 - 3. Submittal Review Time: Include review and resubmittal times indicated in Section "Submittal Procedures" in schedule. Coordinate submittal review times in Contractor's Construction Schedule with Submittals Schedule.
 - 4. Startup and Testing Time: Include not less than 30 days for startup and testing.
 - 5. Substantial Completion: Indicate completion in advance of date established for Substantial Completion, and allow time for the Owner's Consultant and Construction Manager's administrative procedures necessary for certification of Substantial Completion.

- D. Constraints: Include constraints and work restrictions indicated in the Contract Documents and as follows in schedule, and show how the sequence of the Work is affected.
1. Phasing: Arrange list of activities on schedule by phase.
 2. Work under More Than One Contract: Include a separate activity for each contract.
 3. Work by Owner: Include a separate activity for each portion of the Work performed by Owner.
 4. Products Ordered in Advance: Include a separate activity for each product. Include delivery date indicated in Section "Summary." Delivery dates indicated stipulate the earliest possible delivery date.
 5. Owner-Furnished Products: Include a separate activity for each product. Include delivery date indicated in Section "Summary." Delivery dates indicated stipulate the earliest possible delivery date.
 6. Work Restrictions: Show the effect of the following items on the schedule:
 - a. Coordination with existing construction.
 - b. Limitations of continued occupancies.
 - c. Uninterruptible services.
 - d. Use of premises restrictions.
 - e. Provisions for future construction.
 - f. Seasonal variations.
 - g. Environmental control.
 7. Work Stages: Indicate important stages of construction for each major portion of the Work, including, but not limited to, the following:
 - a. Subcontract awards.
 - b. Submittals.
 - c. Purchases.
 - d. Fabrication.
 - e. Sample testing.
 - f. Deliveries.
 - g. Installation.
 - h. Tests and inspections.
 - i. Adjusting.
 - j. Curing.
 - k. Startup and placement into final use and operation.
- E. Milestones: Include milestones indicated in the Contract Documents in schedule, including, but not limited to the Notice to Proceed, Substantial Completion, and Final Completion.
- F. Cost Correlation: At the head of schedule, provide a cost correlation line, indicating planned and actual costs. On the line, show dollar volume of the Work performed as of dates used for preparation of payment requests.
1. Refer to Section "Payment Procedures" for cost reporting and payment procedures.
- G. Contract Modifications: For each proposed contract modification and concurrent with its submission, prepare a time-impact analysis using fragnets to demonstrate the effect of the proposed change on the overall project schedule.

H. Computer Software: Prepare schedules using a program that has been developed specifically to manage construction schedules.

1. Microsoft Project, Version 2010, for Windows XP Professional operating system.

2.3 PRELIMINARY CONSTRUCTION SCHEDULE

A. Preparation: Indicate each significant construction activity separately. Identify first workday of each week with a continuous vertical line. Outline significant construction activities for first 60 days of construction. Include skeleton diagram for the remainder of the Work and a cash requirement prediction based on indicated activities.

2.4 CONTRACTOR'S CONSTRUCTION SCHEDULE (CPM SCHEDULE)

A. General: Prepare network diagrams using AON (activity-on-node) format.

B. Preliminary Network Diagram: Submit diagram within 14 days of date established for the Notice of Award. Outline significant construction activities for the first 60 days of construction. Include skeleton diagram for the remainder of the Work and a cash requirement prediction based on indicated activities.

C. CPM Schedule: Prepare Contractor's Construction Schedule using a CPM network analysis diagram.

1. Develop network diagram in sufficient time to submit CPM schedule so it can be the Notice of Award.

2. Conduct educational workshops to train and inform key Project personnel, including subcontractors' personnel, in proper methods of providing data and using CPM schedule information.

3. Establish procedures for monitoring and updating CPM schedule and for reporting progress. Coordinate procedures with progress meeting and payment request dates.

4. Use "one workday" as the unit of time.

D. CPM Schedule Preparation: Prepare a list of all activities required to complete the Work. Using the preliminary network diagram, prepare a skeleton network to identify probable critical paths.

1. Activities: Indicate the estimated time duration, sequence requirements, and relationship of each activity in relation to other activities. Include estimated time frames for the following activities:

- a. Preparation and processing of submittals.
- b. Purchase of materials.
- c. Delivery.
- d. Fabrication.
- e. Installation.

2. Processing: Process data to produce output data or a computer-drawn, time-scaled network. Revise data, reorganize activity sequences, and reproduce as often as necessary to produce the CPM schedule within the limitations of the Contract Time.

3. Format: Mark the critical path. Locate the critical path near center of network; locate paths with most float near the edges.

- a. Subnetworks on separate sheets are permissible for activities clearly off the critical path.

- E. Initial Issue of Schedule: Prepare initial network diagram from a list of straight "early start-total float" sort. Identify critical activities. Prepare tabulated reports showing the following:
1. Contractor or subcontractor and the Work or activity.
 2. Description of activity.
 3. Principal events of activity.
 4. Immediate preceding and succeeding activities.
 5. Early and late start dates.
 6. Early and late finish dates.
 7. Activity duration in workdays.
 8. Total float or slack time.
 9. Average size of workforce.
 10. Dollar value of activity (coordinated with the Schedule of Values).
- F. Schedule Updating: Concurrent with making revisions to schedule, prepare tabulated reports showing the following:
1. Identification of activities that have changed.
 2. Changes in early and late start dates.
 3. Changes in early and late finish dates.
 4. Changes in activity durations in workdays.
 5. Changes in the critical path.
 6. Changes in total float or slack time.
 7. Changes in the Contract Time.
- G. Value Summaries: Prepare two cumulative value lists, sorted by finish dates.
1. In first list, tabulate activity number, early finish date, dollar value, and cumulative dollar value.
 2. In second list, tabulate activity number, late finish date, dollar value, and cumulative dollar value.
 3. In subsequent issues of both lists, substitute actual finish dates for activities completed as of list date.
 4. Prepare list for ease of comparison with payment requests; coordinate timing with progress meetings.
 - a. In both value summary lists, tabulate "actual percent complete" and "cumulative value completed" with total at bottom.
 - b. Submit value summary printouts one week] before each regularly scheduled progress meeting.

2.5 REPORTS

- A. Daily Construction Reports: Prepare a daily construction report recording the following information concerning events at Project site:
1. List of subcontractors at Project site.
 2. List of separate contractors at Project site.
 3. Approximate count of personnel, by spread and crew, at Project site.
 4. List of both active and in-active equipment
 5. High and low temperatures and general weather conditions.
 6. Accidents.

7. Meetings and significant decisions.
 8. Unusual events (refer to special reports).
 9. Stoppages, delays, shortages, and losses.
 10. Meter readings and similar recording.
 11. Emergency procedures.
 12. Orders and requests of authorities having jurisdiction.
 13. Change Orders received and implemented.
 14. Work Change Directives received.
 15. Service connected and disconnected.
 16. Equipment or system tests and startups.
 17. Partial Completions and occupancies.
 18. Substantial Completions authorized.
- B. Material Location Reports: At monthly intervals, prepare a comprehensive list of materials delivered to and stored at Project site. List shall be cumulative, showing materials previously reported plus items recently delivered. Include with list a statement of progress on and delivery dates for materials or items of equipment fabricated or stored away from Project site.
- C. Field Condition Reports: Immediately on discovery of a difference between field conditions and the Contract Documents, prepare a detailed report. Submit with a request for information on CSI Form 13.2A. Include a detailed description of the differing conditions, together with recommendations for changing the Contract Documents.

2.6 SPECIAL REPORTS

- A. General: Submit special reports directly to Owner within one day of an occurrence. Distribute copies of report to parties affected by the occurrence.
- B. Reporting Unusual Events: When an event of an unusual and significant nature occurs at Project site, whether or not related directly to the Work, prepare and submit a special report. List chain of events, persons participating, and response by Contractor's personnel, evaluation of results or effects, and similar pertinent information. Advise Owner in advance when these events are known or predictable.

PART 3 - EXECUTION

3.1 CONTRACTOR'S CONSTRUCTION SCHEDULE

- A. Contractor's Construction Schedule Updating: At monthly intervals, update schedule to reflect actual construction progress and activities. Issue schedule 1 week before each regularly scheduled progress meeting.
1. Revise schedule immediately after each meeting or other activity where revisions have been recognized or made. Issue updated schedule concurrently with the report of each such meeting.
 2. Include a report with updated schedule that indicates every change, including, but not limited to, changes in logic, durations, actual starts and finishes, and activity durations.
 3. As the Work progresses, indicate Actual Completion percentage for each activity.

- B. Distribution: Distribute copies of approved schedule to the Owner's Representative, Construction Manager, Owner, testing and inspecting agencies, and other parties identified by Contractor with a need-to-know schedule responsibility.
 - 1. Post copies in Project meeting rooms and temporary field offices.
 - 2. When revisions are made, distribute updated schedules to the same parties and post in the same locations. Delete parties from distribution when they have completed their assigned portion of the Work and are no longer involved in performance of construction activities.

3.2 CONSTRUCTION PHOTOGRAPHS

- A. Date Stamp: Unless otherwise indicated, date and time stamp each photograph as it is being taken so stamp is integral to photograph.
- B. Preconstruction Photographs: Before starting construction, take ample digital photographs of Project site and surrounding properties from different vantage points, as directed by Construction Manager. Show existing conditions adjacent to property.
- C. Periodic Construction Photographs: Take ample digital color photographs monthly, coinciding with cutoff date associated with each Application for Payment. Photographer shall select vantage points to best show status of construction and progress since last photographs were taken.
 - 1. Field Office Prints: Retain an electronic set of photographs in field office at Project site, available at all times for reference. Identify photographs the same as for those submitted to the Owner's Representative and Construction Manager.
- D. Final Completion Construction Photographs: Take ample digital photographs after date of Substantial Completion for submission as Project Record Documents. Construction Manager will direct photographer for desired vantage points.

END OF SECTION

SECTION 013300 - SUBMITTAL PROCEDURES

PART 1 - GENERAL

1.1 SUMMARY

- A. This Section includes administrative and procedural requirements for submitting Shop Drawings, Product Data, Samples, and other miscellaneous submittals.

1.2 DEFINITIONS

- A. Action Submittals: Written and graphic information that requires Owner Consultant's and Construction Manager's responsive action.
- B. Informational Submittals: Written information that does not require Owner Consultant's and Construction Manager's approval. Submittals may be rejected for not complying with requirements.
- C. File Transfer Protocol (FTP): Communications protocol that enables transfer of files to and from another computer over a network and that serves as the basis for standard Internet protocols. An FTP site is a portion of a network located outside of network firewalls within which internal and external users are able to access files.
- D. Portable Document Format (PDF): An open standard file format licensed by Adobe Systems used for representing documents in a device-independent and display resolution-independent fixed-layout document format.
 - 1. Submittal Administrative Requirements:
 - a. Engineer's Digital Data Files: Electronic digital data files of the Contract Drawings will be provided by Owner's Representative for Contractor's use in preparing submittals.
 - 1) Owner's Consultant will furnish Contractor one set of digital data drawing files of the Contract Drawings for use in preparing Shop Drawings and Project record drawings.
 - a) Owner's Consultant makes no representations as to the accuracy or completeness of digital data drawing files as they relate to the Contract Drawings.
 - b) Digital Drawing were prepared using AutoCAD Software.
 - c) Digital data drawing files will made available after signing a CAD release form.
 - b. Coordination: Coordinate preparation and processing of submittals with performance of construction activities.
 - 1) Coordinate each submittal with fabrication, purchasing, testing, delivery, other submittals, and related activities that require sequential activity.

- 2) Submit all submittal items required for each Specification Section concurrently unless partial submittals for portions of the Work are indicated on approved submittal schedule.
 - 3) Submit action submittals and informational submittals required by the same Specification Section as separate packages under separate transmittals.
 - 4) Retain subparagraph below if one submittal has an impact on another submittal. Submittals that require concurrent review should be so indicated in those Sections.
 - 5) Coordinate transmittal of different types of submittals for related parts of the Work so processing will not be delayed because of need to review submittals concurrently for coordination.
 - a) Owner's Consultant's and Construction Manager reserve the right to withhold action on a submittal requiring coordination with other submittals until related submittals are received.
- c. Processing Time: Allow time for submittal review, including time for resubmittals, as follows. Time for review shall commence on Construction Manager's receipt of submittal. No extension of the Contract Time will be authorized because of failure to transmit submittals enough in advance of the Work to permit processing, including resubmittals.
- 1) Initial Review: Allow 15 days for initial review of each submittal. Allow additional time if coordination with subsequent submittals is required. Construction Manager will advise Contractor when a submittal being processed must be delayed for coordination.
 - 2) Intermediate Review: If intermediate submittal is necessary, process it in same manner as initial submittal.
 - 3) Resubmittal Review: Allow 15 days for review of each resubmittal.
 - 4) Sequential Review: Where sequential review of submittals by Owner's Consultants, Owner, or other parties is indicated, allow 21 days for initial review of each submittal.
 - 5) Concurrent Consultant Review: Where the Contract Documents indicate that submittals may be transmitted simultaneously to Owner's Consultants and Construction Manager, allow 15 days for review of each submittal. Submittal will be returned to Construction Manager, before being returned to Contractor.

E Electronic Submittals: Identify and incorporate information in each electronic submittal file as follows:

1. Assemble complete submittal package into a single indexed file incorporating submittal requirements of a single Specification Section and transmittal form with links enabling navigation to each item.

2. Name file with submittal number or other unique identifier, including revision identifier.
 - a. File name shall use project identifier and Specification Section number followed by a decimal point and then a sequential number (e.g., LNHS-061000.01). Resubmittals shall include an alphabetic suffix after another decimal point (e.g., LNHS-061000.01.A).
3. Provide means for insertion to permanently record Contractor's review and approval markings and action taken by Owner's Consultant and Construction Manager.
4. Transmittal Form for Electronic Submittals: Use software-generated form from electronic project management software acceptable to Owner, containing the following information:
 - a. Project name.
 - b. Date.
 - c. Name and address of Owner's Consultant
 - d. Name of Contractor.
 - e. Name of firm or entity that prepared submittal.
 - f. Names of subcontractor, manufacturer, and supplier.
 - g. Category and type of submittal.
 - h. Submittal purpose and description.
 - i. Specification Section number and title.
 - j. Specification paragraph number or drawing designation and generic name for each of multiple items.
 - k. Drawing number and detail references, as appropriate.
 - l. Location(s) where product is to be installed, as appropriate.
 - m. Related physical samples submitted directly.
 - n. Indication of full or partial submittal.
 - o. Transmittal number, numbered consecutively.
 - p. Submittal and transmittal distribution record.
 - q. Other necessary identification.
 - r. Remarks.

5. Metadata: Include the following information as keywords in the electronic submittal file metadata:
- a. Project name.
 - b. Number and title of appropriate Specification Section.
 - c. Manufacturer name.
 - d. Product name.
- F. Deviations and Additional Information: On an attached separate sheet, prepared on Contractor's letterhead, record relevant information, requests for data, revisions other than those requested by Owner's Representative and Construction Manager on previous submittals, and deviations from requirements in the Contract Documents, including minor variations and limitations. Include same identification information as related submittal.
- G. Resubmittals: Make resubmittals in same form and number of copies as initial submittal.
1. Note date and content of previous submittal.
 2. Note date and content of revision in label or title block and clearly indicate extent of revision.
 3. Resubmit submittals until they are marked with approval notation from Owner's Consultant and Construction Manager's action stamp.
- H. Distribution: Furnish copies of final submittals to manufacturers, subcontractors, suppliers, fabricators, installers, authorities having jurisdiction, and others as necessary for performance of construction activities. Show distribution on transmittal forms.
- I. Use for Construction: Retain complete copies of submittals on Project site. Use only final action submittals that are marked with approval notation from Owner's Consultant's and Construction Manager's action stamp.

PART 2 - PRODUCTS

2.1 SUBMITTAL PROCEDURES

- A. General Submittal Procedure Requirements: Prepare and submit submittals required by individual Specification Sections. Types of submittals are indicated in individual Specification Sections.
1. Post electronic submittals as PDF electronic files directly to Project Web site specifically established for Project.
 - a. Owner's Consultant, through Construction Manager, will return annotated file. Annotate and retain one copy of file as an electronic Project record document file.
 2. Submit electronic submittals via email as PDF electronic files.
 - a. Owner's Consultant, through Construction Manager, will return annotated file. Annotate and retain one copy of file as an electronic Project record document file.
 3. Action Submittals: Submit three paper copies of each submittal unless otherwise indicated. Owner's Representative, through Construction Manager, will return two copies.

4. Informational Submittals: Submit two paper copies of each submittal unless otherwise indicated. Owner's Consultant and Construction Manager will not return copies.
 5. Certificates and Certifications Submittals: Provide a statement that includes signature of entity responsible for preparing certification. Certificates and certifications shall be signed by an officer or other individual authorized to sign documents on behalf of that entity.
 - a. Provide a digital signature with digital certificate on electronically submitted certificates and certifications where indicated.
 - b. Provide a notarized statement on original paper copy certificates and certifications where indicated.
- B. Product Data: Collect information into a single submittal for each element of construction and type of product or equipment.
1. If information must be specially prepared for submittal because standard published data are not suitable for use, submit as Shop Drawings, not as Product Data.
 2. Mark each copy of each submittal to show which products and options are applicable.
 3. Include the following information, as applicable:
 - a. Manufacturer's catalog cuts.
 - b. Manufacturer's product specifications.
 - c. Standard color charts.
 - d. Statement of compliance with specified referenced standards.
 - e. Testing by recognized testing agency.
 - f. Application of testing agency labels and seals.
 - g. Notation of coordination requirements.
 - h. Availability and delivery time information.
 4. Submit Product Data before or concurrent with Samples.
 5. Submit Product Data in the following format:
 - a. PDF electronic file.
 - b. Three paper copies of Product Data unless otherwise indicated. Consultant, through Construction Manager, will return two copies.
- C. Shop Drawings: Prepare Project-specific information, drawn accurately to scale. Do not base Shop Drawings on reproductions of the Contract Documents or standard printed data, unless submittal based on Owner's Consultant's digital data drawing files is otherwise permitted.
1. Preparation: Fully illustrate requirements in the Contract Documents. Include the following information, as applicable:
 - a. Identification of products.
 - b. Schedules.
 - c. Compliance with specified standards.
 - d. Notation of coordination requirements.
 - e. Notation of dimensions established by field measurement.

- f. Relationship and attachment to adjoining construction clearly indicated.
 - g. Seal and signature of professional engineer if specified.
 - 2. Sheet Size: Except for templates, patterns, and similar full-size drawings, submit Shop Drawings on sheets at least [8-1/2 by 11 inches (215 by 280 mm), but no larger than 30 by 42 inches (750 by 1067 mm)]
 - 3. Submit Shop Drawings in the following format:
 - a. PDF electronic file.
- D. Product Schedule: As required in individual Specification Sections, prepare a written summary indicating types of products required for the Work and their intended location. Include the following information in tabular form:
 - 1. Type of product. Include unique identifier for each product indicated in the Contract Documents or assigned by Contractor if none is indicated.
 - 2. Manufacturer and product name, and model number if applicable.
 - 3. Number and name of room or space.
 - 4. Location within room or space.
 - 5. Submit product schedule in the following format:
 - a. PDF electronic file.
- E. Coordination Drawing Submittals: Comply with requirements specified in Division 01 Section "Project Management and Coordination."
- F. Contractor's Construction Schedule: Comply with requirements specified in Division 01 Section "Construction Progress Documentation."
- G. Application for Payment and Schedule of Values: Comply with requirements specified in Division 01 Section "Payment Procedures."
- H. Test and Inspection Reports and Schedule of Tests and Inspections Submittals: Comply with requirements specified in Division 01 Section "Quality Requirements."
- I. Closeout Submittals and Maintenance Material Submittals: Comply with requirements specified in Division 01 Section "Closeout Procedures."
- J. Maintenance Data: Comply with requirements specified in Division 01 Section "Operation and Maintenance Data."
- K. Qualification Data: Prepare written information that demonstrates capabilities and experience of firm or person. Include lists of completed projects with project names and addresses, contact information of Engineers and owners, and other information specified.
- L. Welding Certificates: Prepare written certification that welding procedures and personnel comply with requirements in the Contract Documents. Submit record of Welding Procedure Specification and Procedure Qualification Record on AWS forms. Include names of firms and personnel certified.

- M. Installer Certificates: Submit written statements on manufacturer's letterhead certifying that Installer complies with requirements in the Contract Documents and, where required, is authorized by manufacturer for this specific Project.
- N. Manufacturer Certificates: Submit written statements on manufacturer's letterhead certifying that manufacturer complies with requirements in the Contract Documents. Include evidence of manufacturing experience where required.
- O. Product Certificates: Submit written statements on manufacturer's letterhead certifying that product complies with requirements in the Contract Documents.
- P. Material Certificates: Submit written statements on manufacturer's letterhead certifying that material complies with requirements in the Contract Documents.
- Q. Material Test Reports: Submit reports written by a qualified testing agency, on testing agency's standard form, indicating and interpreting test results of material for compliance with requirements in the Contract Documents.
- R. Product Test Reports: Submit written reports indicating that current product produced by manufacturer complies with requirements in the Contract Documents. Base reports on evaluation of tests performed by manufacturer and witnessed by a qualified testing agency, or on comprehensive tests performed by a qualified testing agency.
- S. Preconstruction Test Reports: Submit reports written by a qualified testing agency, on testing agency's standard form, indicating and interpreting results of tests performed before installation of product, for compliance with performance requirements in the Contract Documents.
- T. Compatibility Test Reports: Submit reports written by a qualified testing agency, on testing agency's standard form, indicating and interpreting results of compatibility tests performed before installation of product. Include written recommendations for primers and substrate preparation needed for adhesion.
- U. Field Test Reports: Submit written reports indicating and interpreting results of field tests performed either during installation of product or after product is installed in its final location, for compliance with requirements in the Contract Documents.
- V. Design Data: Prepare and submit written and graphic information, including, but not limited to, performance and design criteria, list of applicable codes and regulations, and calculations. Include list of assumptions and other performance and design criteria and a summary of loads. Include load diagrams if applicable. Provide name and version of software, if any, used for calculations. Include page numbers.
- W. Construction Photographs and Videotapes: Comply with requirements in Division 1 Section "Construction Progress Documentation."

2.2 DELEGATED-DESIGN SERVICES

- A. Performance and Design Criteria: Where professional design services or certifications by a design professional are specifically required of Contractor by the Contract Documents, provide products and systems complying with specific performance and design criteria indicated.
1. If criteria indicated are not sufficient to perform services or certification required, submit a written request for additional information to Owner's Representative.

- B. Delegated-Design Services Certification: In addition to Shop Drawings, Product Data, and other required submittals, submit digitally signed PDF electronic file and three paper copies of certificate, signed and sealed by the responsible design professional, for each product and system specifically assigned to Contractor to be designed or certified by a design professional.
1. Indicate that products and systems comply with performance and design criteria in the Contract Documents. Include list of codes, loads, and other factors used in performing these services.

2.3 CONTRACTOR'S PROJECT HEALTH & SAFETY PLAN

- A. No later than the Pre-construction meeting, the Contractor shall submit to the Construction Manager a written Health & Safety Plan which states the Contractor's company policy relative to safety. The plan must also address specific health and safety concerns which are expected to be encountered on the project. As a minimum this plan shall include:
1. Listing of project and company safety officers
 2. Specific company safety policies
 3. Employee Safety Training Program
 4. Administrative procedures to handle employee health & safety concerns
 5. Procedures for insuring worker compliance with health and safety requirements.
- B. The Contractor shall be responsible to insure that each Subcontractor employed on the project complies with the requirements of this section either by submitting a copy of the subcontractor's Project Health & Safety Plan or by submitting a letter from the Subcontractor stating that they will comply with the provisions of the Contractor's Project Health & Safety Plan.
- C. Submission of the required Project Health & Safety Plan by the Contractor is primarily for information or record purposes and shall not be construed to imply approval by the Owner or to relieve the Contractor from the responsibility to adequately protect the health & safety of all workers involved in the project.

PART 3 - EXECUTION

3.1 CONTRACTOR'S REVIEW

- A. Review each submittal and check for compliance with the Contract Documents. Note corrections and field dimensions. Mark with approval stamp before submitting to Construction Manager.
- B. Approval Stamp: Stamp each submittal with a uniform, approval stamp. Include Project name and location, submittal number, Specification Section title and number, name of reviewer, date of Contractor's approval, and statement certifying that submittal has been reviewed, checked, and approved for compliance with the Contract Documents.

3.2 OWNER'S CONSULTANT'S AND CONSTRUCTION MANAGER'S ACTION

- A. General: Owner's Consultant and Construction Manager will not review submittals that do not bear Contractor's approval stamp and will return them without action.
- B. Action Submittals: Owner's Consultant and Construction Manager will review each submittal, make marks to indicate corrections or modifications required, and return it. Owner's Representative and Construction Manager will stamp each submittal with an action stamp and will mark stamp appropriately to indicate action taken, as follows:

1. Final Unrestricted Release: Where submittals are marked “No Exceptions Taken,” that part of the Work covered by the submittal may proceed provided it complies with requirements of the Contract Documents; final acceptance will depend upon that compliance.
 2. Final-But-Restricted Release: When submittals are marked “Make Corrections Noted,” that part of the Work covered by the submittal may proceed provided it complies with notations or corrections on the submittal and requirements of the Contract Documents; final acceptance will depend on that compliance.
 3. Returned for Resubmittal: When submittal is marked “Revise and Resubmit,” “Rejected,” or “Submit Specified Item,” do not proceed with that part of the Work covered by the submittal, including purchasing, fabrication, delivery, or other activity. Revise or prepare a new submittal in accordance with the notations; resubmit without delay. Repeat if necessary to obtain a different action mark.
 - a. Do not permit submittals marked “Revise and Resubmit,” “Rejected,” or “Submit Specified Item” to be used at the Project site, or elsewhere where Work is in progress.
 4. Other Action: Where a submittal is primarily for information or record purposes, special processing or other activity, the submittal will be returned, marked “Action Not Required.”
- C. Informational Submittals: Owner’s Consultant and Construction Manager will review each submittal and will not return it, or will reject and return it if it does not comply with requirements. Owner’s Representative and Construction Manager will forward each submittal to appropriate party.
- D. Submittals not required by the Contract Documents will not be reviewed and may be discarded.

END OF SECTION

SECTION 014000- QUALITY REQUIREMENTS

PART 1 - GENERAL

1.1 SUMMARY

- A. This Section includes administrative and procedural requirements for quality assurance and quality control.
- B. Testing and inspecting services are required to verify compliance with requirements specified or indicated. These services do not relieve Contractor of responsibility for compliance with the Contract Document requirements.
 - 1. Specific quality-control requirements for individual construction activities are specified in the Sections that specify those activities. Requirements in those Sections may also cover production of standard products.
 - 2. Specified tests, inspections, and related actions do not limit Contractor's quality-control procedures that facilitate compliance with the Contract Document requirements.
 - 3. Requirements for Contractor to provide quality-control services required by Owner's Representative, Owner, or authorities having jurisdiction are not limited by provisions of this Section.

1.2 DEFINITIONS

- A. Quality-Assurance Services: Activities, actions, and procedures performed before and during execution of the Work to guard against defects and deficiencies and ensure that proposed construction complies with requirements.
- B. Quality-Control Services: Tests, inspections, procedures, and related actions during and after execution of the Work to evaluate that completed construction complies with requirements. Services do not include contract enforcement activities performed by Engineer.
- C. Testing Agency: An entity engaged to perform specific tests, inspections, or both. Testing laboratory shall mean the same as testing agency.

1.3 DELEGATED DESIGN

- A. Performance and Design Criteria: Where professional design services or certifications by a design professional are specifically required of Contractor by the Contract Documents, provide products and systems complying with specific performance and design criteria indicated.
 - 1. If criteria indicated are not sufficient to perform services or certification required, submit a written request for additional information to Owner's Representative.

1.4 SUBMITTALS

- A. Qualification Data: For testing agencies specified in "Quality Assurance" Article to demonstrate their capabilities and experience. Include proof of qualifications in the form of a recent report on the inspection of the testing agency by a recognized authority.

- B. Delegated-Design Submittal: In addition to Shop Drawings, Product Data, and other required submittals, submit a statement, signed and sealed by the responsible design professional, for each product and system specifically assigned to Contractor to be designed or certified by a design professional, indicating that the products and systems are in compliance with performance and design criteria indicated. Include list of codes, loads, and other factors used in performing these services.
- C. Schedule of Tests and Inspections: Prepare in tabular form and include the following:
1. Specification Section number and title.
 2. Description of test and inspection.
 3. Identification of applicable standards.
 4. Identification of test and inspection methods.
 5. Number of tests and inspections required.
 6. Time schedule or time span for tests and inspections.
 7. Entity responsible for performing tests and inspections.
 8. Requirements for obtaining samples.
 9. Unique characteristics of each quality-control service.
- D. Reports: Prepare and submit certified written reports, that include the following:
1. Date of issue.
 2. Project title and number.
 3. Name, address, and telephone number of testing agency.
 4. Dates and locations of samples and tests or inspections.
 5. Names of individuals making tests and inspections.
 6. Description of the Work and test and inspection method.
 7. Identification of product and Specification Section.
 8. Complete test or inspection data.
 9. Test and inspection results and an interpretation of test results.
 10. Ambient conditions at time of sample taking and testing and inspecting.
 11. Comments or professional opinion on whether tested or inspected Work complies with the Contract Document requirements.
 12. Name and signature of laboratory inspector.
 13. Recommendations on retesting and reinspecting.
- E. Permits, Licenses, and Certificates: For Owner's records, submit copies of permits, licenses, certifications, inspection reports, releases, notices, receipts for fee payments, , correspondence, records, and similar documents, established for compliance with standards and regulations bearing on performance of the Work.

1.5 QUALITY ASSURANCE

- A. Fabricator Qualifications: A firm experienced in producing products similar to those indicated for this Project and with a record of successful in-service performance, as well as sufficient production capacity to produce required units.
- B. Factory-Authorized Service Representative Qualifications: An authorized representative of manufacturer who is trained and approved by manufacturer to inspect installation of manufacturer's products that are similar in material, design, and extent to those indicated for this Project.
- C. Installer Qualifications: A firm or individual experienced in installing, erecting, or assembling work similar in material, design, and extent to that indicated for this Project, whose work has resulted in construction with a record of successful in-service performance.
- D. Manufacturer Qualifications: A firm experienced in manufacturing products or systems similar to those indicated for this Project and with a record of successful in-service performance.
- E. Engineering services are defined as those performed for installations of the system, assembly, or products that are similar to those indicated for this Project in material, design, and extent.
- F. Specialists: Certain sections of the Specifications require that specific construction activities shall be performed by entities who are recognized experts in those operations. Specialists shall satisfy qualification requirements indicated and shall be engaged for the activities indicated.
1. Requirement for specialists shall not supersede regulations governing the Work, nor interfere with local trade-union jurisdictional settlements and similar conventions.
- G. Testing Agency Qualifications: An agency with the experience and capability to conduct testing and inspecting indicated, as documented by ASTM E 548, that specializes in types of tests and inspections to be performed. Each testing agency shall be authorized by the authorities having jurisdiction in the state in which the project is located.
- H. Preconstruction Testing: Testing agency shall perform preconstruction testing for compliance with specified requirements for performance and test methods.
1. Contractor responsibilities include the following:
 - a. Provide test specimens and assemblies representative of proposed materials and construction. Provide sizes and configurations of assemblies to adequately demonstrate capability of product to comply with performance requirements.
 - b. Submit specimens in a timely manner with sufficient time for testing and analyzing results to prevent delaying the Work.
 - c. Fabricate and install test assemblies using installers who will perform the same tasks for Project.
 - d. When testing is complete, remove assemblies; do not reuse materials on Project.
 2. Testing Agency Responsibilities: Submit a certified written report of each test, inspection, and similar quality-assurance service to Owner's Representative through Construction Manager, with copy to Contractor. Interpret tests and inspections and state in each report whether tested and inspected work complies with or deviates from the Contract Documents.

1.6 QUALITY CONTROL

- A. Owner Responsibilities: Where quality-control services are indicated as Owner's responsibility, Owner will engage a qualified testing agency to perform these services.
1. Owner will furnish Contractor with names, addresses, and telephone numbers of testing agencies engaged and a description of the types of testing and inspecting they are engaged to perform.
 2. Costs for retesting and re-inspecting construction that replaces or is necessitated by work that failed to comply with the Contract Documents will be charged to Contractor, and the Contract Sum will be adjusted by Change Order.
- B. Contractor Responsibilities: Unless otherwise indicated, provide quality-control services specified and required by authorities having jurisdiction.
1. Where services are indicated as Contractor's responsibility, engage a qualified testing agency to perform these quality-control services. Contractor will furnish Owner with names, addresses, and telephone numbers of testing agencies engaged and a description of the types of testing and inspecting they are engaged to perform.
 - a. Contractor shall not employ the same entity engaged by Owner, unless agreed to in writing by Owner.
 2. Notify testing agencies at least **24** hours in advance of time when Work that requires testing or inspecting will be performed.
 3. Where quality-control services are indicated as Contractor's responsibility, submit a certified written report, in duplicate, of each quality-control service.
 4. Testing and inspecting requested by Contractor and not required by the Contract Documents are Contractor's responsibility.
 5. Submit additional copies of each written report directly to authorities having jurisdiction, when they so direct.
- C. Tests and Inspections: Owner will engage a testing agency to conduct special tests and inspections required by authorities having jurisdiction and identified as the responsibility of Owner.
1. Testing Agency will notify Construction Manager and Contractor promptly of irregularities and deficiencies observed in the Work during performance of its services.
 2. Testing Agency will submit a certified written report of each test, inspection, and similar quality-control service to Construction Manager with copy to Contractor and to authorities having jurisdiction.
 3. Testing Agency will submit a final report of special tests and inspections at Substantial Completion, which includes a list of unresolved deficiencies.
 4. Testing Agency will interpret tests and inspections and state in each report whether tested and inspected work complies with or deviates from the Contract Documents.
 5. Testing Agency will retest and reinspect corrected work.

- D. **Manufacturer's Field Services:** Where indicated, engage a factory-authorized service representative to inspect field-assembled components and equipment installation, including service connections. Report results in writing.
- E. **Retesting/Re-inspecting:** Regardless of whether original tests or inspections were Contractor's responsibility, provide quality-control services, including retesting and re-inspecting, for construction that revised or replaced Work that failed to comply with requirements established by the Contract Documents.
- F. **Testing Agency Responsibilities:** Cooperate with Owner's Representative and Contractor in performance of duties. Provide qualified personnel to perform required tests and inspections.
1. Notify Owner's Representative and Contractor promptly of irregularities or deficiencies observed in the Work during performance of its services.
 2. Interpret tests and inspections and state in each report whether tested and inspected work complies with or deviates from requirements.
 3. Submit a certified written report, in duplicate, of each test, inspection, and similar quality-control service.
 4. Do not release, revoke, alter, or increase requirements of the Contract Documents or approve or accept any portion of the Work.
 5. Do not perform any duties of Contractor.
- G. **Associated Services:** The Contractor shall cooperate with agencies performing required tests, inspections, and similar quality-control services, and provide reasonable auxiliary services as requested. Notify Testing Agency sufficiently in advance of operations to permit assignment of personnel. Provide the following:
1. Access to the Work.
 2. Incidental labor and facilities necessary to facilitate tests and inspections.
 3. Adequate quantities of representative samples of materials that require testing and inspecting.
 4. Assist agency in obtaining samples.
 5. Provide facilities for storage and field-curing of test samples.
 6. Delivery of samples to testing agencies.
 7. Preliminary design mix proposed for use for material mixes that require control by testing agency.
 8. Security and protection for samples and for testing and inspecting equipment at Project site.
- H. **Coordination:** Coordinate sequence of activities to accommodate required quality-assurance and quality-control services with a minimum of delay and to avoid necessity of removing and replacing construction to accommodate testing and inspecting.

1. Schedule times for tests, inspections, obtaining samples, and similar activities.
- I. Schedule of Tests and Inspections: Prepare a schedule of tests, inspections, and similar quality-control services required by the Contract Documents. Submit schedule within 10 days of date established for commencement of the Work (i.e., Notice to Proceed).
1. Distribution: Distribute schedule to Owner, Construction Manager, testing agencies, and each party involved in performance of portions of the Work where tests and inspections are required.

PART 2 - PRODUCTS (Not Used)

PART 3 - EXECUTION

3.1 REPAIR AND PROTECTION

- A. General: On completion of testing, inspecting, sample taking, and similar services, repair damaged construction and restore substrates and finishes.
 1. Provide materials and comply with installation requirements specified in other Sections of these Specifications. Restore patched areas and extend restoration into adjoining areas in a manner that eliminates evidence of patching.
- B. Protect construction exposed by or for quality-control service activities.
- C. Repair and protection are Contractor's responsibility, regardless of the assignment of responsibility for quality-control services.

END OF SECTION

SECTION 014200 - REFERENCES

PART 1 - GENERAL

1.1 DEFINITIONS

- A. General: Basic Contract definitions are included in the Conditions of the Contract.
- B. "Approved": The term "approved," when used in conjunction with Owner's Representative's action on Contractor's submittals, applications, and requests, is limited to Owner's Representative's duties and responsibilities as stated in the Conditions of the Contract.
- C. "Directed": Terms such as "directed," "requested," "authorized," "selected," "approved," "required," and "permitted" mean directed by Engineer, requested by Engineer, and similar phrases.
- D. "Indicated": The term "indicated" refers to graphic representations, notes, or schedules on Drawings; or to other paragraphs or schedules in Specifications and similar requirements in the Contract Documents. Terms such as "shown," "noted," "scheduled," and "specified" are used to help the user locate the reference.
- E. "Regulations": The term "regulations" includes laws, ordinances, statutes, and lawful orders issued by authorities having jurisdiction, as well as rules, conventions, and agreements within the construction industry that control performance of the Work.
- F. "Furnish": The term "furnish" is used to mean supply and deliver to Project site, ready for unloading, unpacking, assembly installation, and similar operations..
- G. "Install": The term "install" is used to describe operations at Project site including unloading, temporary storage, unpacking, assembling, erecting, placing, anchoring, applying, working to dimension, finishing, curing, protecting, cleaning, and similar operations.
- H. "Provide": The term "provide" means to furnish and install, complete and ready for the intended use.
- I. "Installer": An installer is the Contractor or another entity engaged by the Contractor, either as an employee, subcontractor, or contractor of lower tier, to perform a particular construction operation, including installation, erection, application, and similar operations. Installers are required to be experienced in the operations they are engaged to perform.
- J. The term "experienced," when used with the term "installer," means having successfully completed previous projects similar in size and scope to this Project; being familiar with the special requirements indicated; and having complied with requirements of authorities having jurisdiction.
1. Trades: Using a term such as "carpentry" does not imply that certain construction activities must be performed by accredited or unionized individual of a corresponding generic name, such as "carpenter". It also does not imply that requirements specified apply exclusively to tradespeople of the corresponding generic name.
 2. Assignment of Specialists: Certain Sections of the Specifications require that specific construction activities shall be performed by specialists who are recognized experts in the operations to be performed. The specialists must be engaged for those activities, and assignments are requirements over which the Contractor has no choice or option.

Nevertheless, the ultimate responsibility for fulfilling Contract requirements remains with the Contractor.

- a. This requirement shall not be interpreted to conflict with enforcement of regulations governing the Work. It is also not intended to interfere with local trade union jurisdictional settlements and similar conventions.
- K. "Project Site" is the space available by Permit and easements to the Contractor for performing construction activities, either exclusively or in conjunction with others performing other work as part of Project. The extent of Project site is shown on the Drawings.
- L. Testing Laboratories: A "testing laboratory" is an independent entity engaged to perform specific inspections or tests, either at the Project Site or elsewhere, and to report on and, if required, to interpret results of those inspections or tests.

1.2 INDUSTRY STANDARDS

- A. Applicability of Standards: Unless the Contract Documents include more stringent requirements, applicable construction industry standards have the same force and effect as if bound or copied directly into the Contract Documents to the extent referenced. Such standards are made a part of the Contract Documents by reference.
- B. Publication Dates: Comply with standards in effect as of the date of the Contract Documents, unless otherwise indicated.
- C. Conflicting Requirements: Where compliance with two or more standards is specified and the standards establish different or conflicting requirements for minimum quantities or quality levels, comply with the most stringent requirement. Refer uncertainties and requirements that are different, but apparently equal, to Construction Manager for a decision before proceeding.
 - 1. Minimum Quantity or Quality Levels: The quantity or quality level shown or specified shall be the minimum provided or performed. The actual installation may comply exactly with the minimum quantity or quality specified, or it may exceed the minimum within reasonable limits. In complying with these requirements, indicated numeric values are minimum or maximum, as appropriate, for the context of the requirements. Refer uncertainties to Construction Manager for a decision before proceeding.
- D. Copies of Standards: Each entity engaged in construction on the Project must be familiar with industry standards applicable to its construction activity. Copies of applicable standards are not bound with the Contract Documents.
 - 1. Where copies of standards are needed to perform a required construction activity, the Contractor shall obtain copies directly from the publication source and make them available on request.
- E. Abbreviations and Names: Abbreviations and acronyms are frequently used in the Specifications and other Contract Documents to represent the name of a trade association, standards-developing organization, and authorities having jurisdiction, or other entity in the context of referencing a standard or publication. Where abbreviations and acronyms are used in the Specifications or other Contract Documents, they mean the recognized name of these entities. Refer to Gale Research's "Encyclopedia of Associations" or Columbia Books' "National Trade & Professional Associations of the U.S.," which are available in most libraries.

1.3 QUALITY ASSURANCE

A. Regulatory Requirements

1. The Owner's Consultants have contacted authorities having jurisdiction over the Work in obtaining information necessary for preparation of Contract Documents and Permits. Contact authorities having jurisdiction directly for information and decisions having a bearing on the Work. The Contractor shall execute the Work in accordance with Permit requirements.
2. Copies of Regulations and Permits: The Contractor shall obtain copies of regulations governing and project permits issued to the Project. Contractor shall retain copies at the Project Site, and make them available to the Construction Manager for reference by parties who have a reasonable need for such reference.

1.4 SUBMITTALS

- A. Permits, Licenses, and Certificates: For the Owner's records, submit copies of permits, licenses, certifications, inspection reports, releases, jurisdictional settlements, notices, receipts for fee payments, judgments, and similar documents, correspondence, and records established for compliance with standards and regulations bearing upon performance of the Work.

PART 2 - PRODUCTS (Not Used)

PART 3 - EXECUTION (Not Used)

END OF SECTION

SECTION 015000- TEMPORARY FACILITIES AND CONTROLS

PART 1 - GENERAL

1.1 SUMMARY

- A. This Section includes requirements for temporary services, facilities and controls, including temporary utilities, support facilities, and security and protection facilities.
- B. Temporary utilities include, but are not limited to, the following:
1. Sewers and drainage.
 2. Water service and distribution.
 3. Sanitary facilities, including toilets, wash facilities, and drinking-water facilities.
 4. Heating and cooling facilities.
 5. Ventilation.
 6. Electric power service.
 7. Lighting.
 8. Telephone and internet service.
- C. Temporary construction and support facilities/equipment include, but are not limited to, the following:
1. Adjust list below to suit Project.
 2. Temporary roads and paving.
 3. Dewatering facilities and drains.
 4. Project identification and temporary signs.
 5. Waste disposal facilities.
 6. Field offices.
 7. Storage and fabrication sheds.
 8. Lifts and hoists.
 9. Temporary stairs.
 10. Construction aids and miscellaneous services and facilities.
 11. Temporary enclosures.
 12. Temporary heat.
 13. Construction Manager All-Terrain Vehicles, including trailers, cell phone boosters, insurance and registration

14. Additional communication means for appropriate personnel including radios, repeaters, stations
- D. Security and protection facilities include, but are not limited to, the following:
1. Adjust list below to suit Project.
 2. Environmental protection.
 3. Stormwater control.
 4. Tree and plant protection.
 5. Pest control.
 6. Site enclosure fence.
 7. Security enclosure and lockup.
 8. Barricades, warning signs, and lights.
 9. Temporary enclosures.
 10. Temporary partitions.
 11. Fire protection.

1.2 USE CHARGES

- A. General: The cost of all use charges for temporary facilities are not chargeable to Owner, Construction Manager, or Engineer and shall be included in the Contract Sum. The contractor shall be responsible for paying all use charges until the project is substantially complete. Allow other entities to use temporary services and facilities without cost, including, but not limited to, the following:
1. Owner's construction and operation forces.
 2. Engineer.
 3. Construction Manager.
 4. Testing agencies.
 5. Personnel of authorities having jurisdiction.
- B. Sewer Service: If necessary, pay sewer service for all parties engaged in construction, at Project sites.
- C. Water Service: Pay water service use charges, whether metered or otherwise, for water used by all entities engaged in construction activities at Project site.
- D. Electric Power Service: Pay electric power service use charges, whether metered or otherwise, for electricity used by all entities engaged in construction activities at Project site.
- E. Communication Service: Pay internet service use charges for internet equipment/service specified for the duration of construction. If applicable, pay applicable radio/repeater fees for all equipment/service specified for the duration of construction.
- F. Transportation Service: Pay insurance, registration and fuel charges for provided all-terrain vehicles.

1.3 SUBMITTALS

- A. Temporary Utility Reports: Submit reports of tests, inspections, utility billings, and similar procedures performed on temporary utilities.

- B. Implementation and Termination Schedule: Within 15 days of date established for submittal of Contractor's Construction Schedule, submit a schedule indicating implementation and termination of each temporary utility.

1.4 QUALITY ASSURANCE

- A. Standards: Comply with ANSI A10.6, NECA's "Temporary Electrical Facilities," and NFPA 241.
 - 1. Trade Jurisdictions: Assigned responsibilities for installation and operation of temporary utilities are not intended to interfere with trade regulations and union jurisdictions.
 - 2. Electric Service: Comply with NECA, NEMA, and UL standards and regulations for temporary electric service. Install service to comply with NFPA 70.
 - 3. Refer to Guidelines for Bid Conditions for Temporary Job Utilities and Services, prepared jointly by AGC and ASC, for industry recommendations.
- B. Tests and Inspections: Arrange for authorities having jurisdiction to test and inspect each temporary utility before use. Obtain required certifications and permits.
- C. Regulations: Comply with industry standards and applicable laws and regulations of authorities having jurisdiction, including but not limited to:
 - 1. Building Code requirements.
 - 2. Health and safety regulations.
 - 3. Utility company regulations.
 - 4. Police, Fire Department and Rescue Squad rules.

1.5 PROJECT CONDITIONS

- A. Conditions of Use: The following conditions apply to use of temporary services and facilities by all parties engaged in the Work:
 - 1. Keep temporary services and facilities clean and neat.
 - 2. Relocate temporary services and facilities as required by progress of the Work.
 - 3. Operate in a safe and efficient manner.
 - 4. Take necessary fire prevention measures.
 - 5. Do not overload facilities or permit them to interfere with progress.
 - 6. Do not allow hazardous, dangerous or unsanitary conditions or public nuisances to develop or persist on the site.

PART 2 - PRODUCTS

2.1 MATERIALS

- A. General: Provide new materials. Undamaged, previously used materials in serviceable condition may be used if approved by Engineer. Provide materials suitable for use intended.

- B. Portable Chain-Link Fencing: Minimum 2-inch (50-mm) 9-gage, galvanized steel, chain-link fabric fencing; minimum 6 feet (1.8 m) high with galvanized steel pipe posts; minimum 2-3/8-inch- (60-mm-) OD line posts and 2-7/8-inch- (73-mm-) OD corner and pull posts, with 1-5/8-inch- (42-mm-) OD top and bottom rails. Provide concrete or galvanized steel bases for supporting posts.
- C. Lumber and Plywood:
1. For job-built temporary offices, shops and sheds within the construction area, provide UL labeled, fire treated lumber and plywood for framing, sheathing and siding.
 2. For signs and directory boards, provide exterior type, Grade B-B High Density Concrete Form Overlay Plywood conforming to PS-1, of sizes and thickness indicated.
 3. For fences and vision barriers, provide exterior type, minimum 3/8" thick plywood.
 4. For safety barriers and similar uses, provide minimum 5/8" thick exterior plywood.
- D. Roofing: Provide UL Class, A standard weight asphalt shingles complying with ASTM D 3018, or UL Class "C mineral surfaced roll roofing complying with ASTM D 249 on roofs of job-built temporary offices, shops and sheds.
- E. Gypsum Board: Minimum 1/2 inch (12.7 mm) thick by 48 inches (1219 mm) wide by maximum available lengths; regular-type panels with tapered edges. Comply with ASTM C 36.
- F. Insulation: Unfaced mineral-fiber blanket manufactured from glass, slag wool, or rock wool; with maximum flame-spread and smoke-developed indices of 25 and 50, respectively.
- G. Paint:
1. For job-built temporary offices, shops, sheds, fences and other exposed lumber and plywood, provide exterior grade acrylic-latex emulsion over exterior primer.
 2. For sign panels and applying graphics, provide exterior grade alkyd gloss enamel over exterior primer.
 3. For interior walls of temporary offices, provide two coats interior latex flat wall paint.
- H. Tarpaulins: Provide waterproof, fire-resistant, UL labeled tarpaulins with flame-spread rating of 15 or less. For temporary enclosures provide translucent nylon reinforced laminated polyethylene or polyvinyl chloride fire retardant tarpaulins.
- I. Water: Provide potable water approved by local health authorities
- 2.2 EQUIPMENT
- A. General: Provide new equipment; if acceptable to the Construction Manager, undamaged, previously used equipment in serviceable condition may be used. Provide equipment suitable for use intended.
- B. Field Offices: Mobile units with lockable entrances, operable windows, and serviceable finishes; heated and air conditioned; on foundations adequate for normal loading.

C. General Requirements for all Construction Managers Offices:

1. Lighting: Electric light, non-glare type luminaries to provide a minimum illumination level of 100 ft. candles at desk height level.
2. Heating and Cooling: Adequate equipment to maintain an ambient air temperature of 70°F \pm 5°F.
3. Telephone: A separate phone for the exclusive use of Construction Manager.
4. Potable Water.
5. First Aid Kit: The Contractor shall keep the kit properly stocked with appropriate first aid supplies at all times.
6. Toilet: A separately enclosed room, properly ventilated and complying with applicable sanitary codes. Wherever possible, the Contractor shall provide a lavatory with running water and flush type toilet.
7. Locker: A wooden locker of sufficient size for storage of surveying instruments and testing equipment.
8. Maintenance: The Contractor shall maintain all facilities and furnished equipment in good working condition.
9. Fire Extinguisher: Non-toxic, dry chemical, fire extinguisher meeting Underwriters Laboratories, Inc., approval for Class A, Class B, and Class C fires with a minimum rating of 2A: 10B: 10C.
10. Fire Resistant Cabinet: Fire resistant, legal size file cabinet with lock and 2 keys, meeting the requirements for "Insulating Filing Devices, Class 350-1 Hour (D) of ANSI/UL 72 or the Class D rating of the original Underwriters Laboratories specification for insulated filing devices. The number of drawers will be specified for each type of office.
11. Thermometer: A minimum - maximum thermometer.
12. Multifunction printer/copier/scanner: floor mount, heavy duty, electric, dry process letter and legal size photocopying machine and an adequate supply of copy paper. The supply of copy paper shall be replenished by the Contractor as required by the Construction Manager.
13. Signs: The Contractor shall furnish and install necessary signs to locate and identify the Construction Manager's Office.

D. Construction Manager's Office:

1. Construction Manager's Office: In addition to the general requirements, provide an approximately 64' x 24' section modular that is partitioned to provide four office rooms and one lavatory facility. The Construction Manager's office shall be located in the same location as the Contractor's primary field office. The furnishings shall be as follows:
 - 8 Suitable office desks with drawers and locks.
 - 16 Office Chairs.

- 4 Fire resistant cabinet, 4-drawer, each and as specified in GENERAL REQUIREMENTS.
 - 2 Drafting-type tables, each three feet by six feet, supported by wall brackets and legs.
 - 2 Draftsmans stools.
 - 1 Office table, four feet by twelve feet.
 - 4 Vertical filing plan racks for four sets of 22" x 36" plans each rack.
 - 2 Roll file unit with twelve 6" x 6" compartments capable of housing twelve cross-section rolls each 22 inch length.
 - 2 Legal size 4-drawer file cabinet.
 - 1 Metal storage cabinet with four adjustable shelves, tumbler lock and two keys (approximate size 72" high by 36" side by 18" deep).
 - 1 High speed internet connection service and wireless router(s) capable of adequately handling up to 12 computers.
 - 3 Additional fire extinguisher as specified in GENERAL REQUIREMENTS.
2. Equip with a water cooler and private toilet complete with water closet, lavatory and mirror-medicine cabinet unit.
- E. Fire Extinguishers: Provide hand-carried, portable UL-rated, class "A fire extinguishers for temporary offices and similar spaces. In other locations provide hand-carried, portable, UL-rated, class "ABC dry chemical extinguishers, or a combination of extinguishers of NFPA recommended classes for the exposures.
1. Comply with NFPA 10 and NFPA 241 for classification, extinguishing agent, and size required by location and class of fire exposure.
- F. Self-Contained Toilet Units: Single-occupant units of chemical, aerated recirculation, or combustion type; vented; fully enclosed with a glass-fiber-reinforced polyester shell or similar nonabsorbent material.
- G. Drinking-Water Fixtures: Containerized, tap-dispenser, bottled-water drinking-water units, including paper cup supply.
1. Where power is accessible, provide electric water coolers to maintain dispensed water temperature at 45 to 55 deg F (7.2 to 12.7 deg C).
- H. Heating Equipment: Unless Owner authorizes use of permanent heating system, provide vented, self-contained, liquid-propane-gas or fuel-oil heaters with individual space thermostatic control.
1. Use of gasoline-burning space heaters, open-flame heaters, or salamander-type heating units is prohibited.
 2. Heating Units: Listed and labeled, by a testing agency acceptable to authorities having jurisdiction, and marked for intended use for type of fuel being consumed.
- I. Electrical Outlets: Properly configured, NEMA-polarized outlets to prevent insertion of 110- to 120-V plugs into higher-voltage outlets; equipped with ground-fault circuit interrupters, reset button, and pilot light.

- J. Power Distribution System Circuits: Where permitted and overhead and exposed for surveillance, wiring circuits, not exceeding 125-V ac, 20-A rating, and lighting circuits may be nonmetallic sheathed cable.
- K. Lamps and Light Fixtures: Provide general service incandescent lamps of wattage required for adequate illumination. Provide guard cages or tempered glass enclosures, where exposed to breakage. Provide exterior fixtures where exposed to moisture.
- L. First Aid Supplies: Comply with governing regulations.
- M. Radios: Contractor shall provide twenty (20) fully programmable repeater capable two way radios (UHF). Radios shall have high capacity lithium batteries with a minimum single charge duration of 15 hours. Contractor shall provide repeater(s) and/or base station(s) as necessary to maintain clear radio communication throughout the entire project area. Repeater(s) and base station(s) shall be compatible with the provided radios.
- N. Transportation Equipment: Contractor shall provide four (4) utility-terrain vehicles (UTV's) for use by the Construction Manager. Requirements of the Transportation Equipment is as follows:
 - 1. Four (4) mid-sized 400 Ranger Series UTV's as manufactured by Polaris, or equal. Registration and insurance as may be required shall be included for the duration of the project.
 - 2. Two (2) tow-behind trailers capable of transporting one UTV as described above. Registration and insurance shall be included for the duration of the project.
 - 3. Cell Phone boosters, one for each UTV, capable of providing clear cell coverage throughout the entire project area.

PART 3 - EXECUTION

3.1 INSTALLATION, GENERAL

- A. Use qualified personnel for installation of temporary facilities. Locate facilities where they will serve Project adequately and result in minimum interference with performance of the Work. Relocate and modify facilities as required.
- B. Provide each facility ready for use when needed to avoid delay. Maintain and modify as required. Do not remove until facilities are no longer needed or are replaced by authorized use of completed permanent facilities.

3.2 TEMPORARY UTILITY INSTALLATION

- A. General: Engage appropriate local utility company to install temporary service or connect to existing service. Where utility company provides only part of the service, provide the remainder with matching, compatible materials and equipment. Comply with utility company recommendations.
 - 1. Arrange with utility company, Owner, and existing users for time when service can be interrupted, if necessary, to make connections for temporary services.

2. Provide adequate capacity at each stage of construction. Before temporary utility is available, provide trucked-in services.
 3. Obtain easements to bring temporary utilities to Project site where Owner's easements cannot be used for that purpose.
- B. Sewers and Drainage: If sewers are available, provide temporary connections to remove effluent that can be discharged lawfully. If sewers can't be lawfully used for discharge of effluent, provide containers to remove and dispose of effluent off-site in a lawful manner.
1. Connect temporary sewers to municipal system or private system as directed by sewer department officials.
 2. Maintain temporary sewers and drainage facilities in a clean, sanitary condition. After heavy use, restore normal conditions promptly.
 3. Provide temporary filter beds, settlement tanks, separators, and similar devices to purify effluent to levels acceptable to authorities having jurisdiction.
- C. Water Service: Install water service and distribution piping in sizes and pressures adequate for construction until permanent water service is in use. Sterilize temporary water piping before use.
- D. Sanitary Facilities: Provide temporary toilets, wash facilities, and drinking-water fixtures. Comply with regulations and health codes for type, number, location, operation, and maintenance of fixtures and facilities.
1. Disposable Supplies: Provide toilet tissue, paper towels, paper cups, and similar disposable materials for each facility. Maintain adequate supply. Provide covered waste containers for disposal of used material.
 2. Toilets: Install self-contained toilet units. Shield toilets to ensure privacy.
 3. Drinking-Water Facilities: Provide bottled-water, drinking-water units.
 - a. Where power is accessible, provide electric water coolers to maintain dispensed water temperature at 45 to 55 deg F (7.2 to 12.7 deg C).
- E. Electric Power Service: Provide weatherproof, grounded electric power service and distribution system of sufficient size, capacity, and power characteristics during construction period. Include meters, transformers, overload-protected disconnecting means, automatic ground-fault interrupters, and main distribution switchgear, as applicable.
1. Install electric power service underground, unless overhead service must be used.
 2. Install power distribution wiring overhead and rise vertically where least exposed to damage.
- F. Electric Distribution: Provide receptacle outlets adequate for connection of power tools and equipment.
1. Provide waterproof connectors to connect separate lengths of electrical power cords if single lengths will not reach areas where construction activities are in progress. Do not exceed safe length-voltage ratio.

2. Provide warning signs at power outlets other than 110 to 120 V.
 3. Provide metal conduit, tubing, or metallic cable for wiring exposed to possible damage. Provide rigid steel conduits for wiring exposed on grades, floors, decks, or other traffic areas.
 4. Provide metal conduit enclosures or boxes for wiring devices.
 5. Provide 4-gang outlets, spaced so 100-foot (30-m) extension cord can reach each area for power hand tools and task lighting. Provide a separate 125-V ac, 20-A circuit for each outlet.
- G. Lighting: Provide temporary lighting with local switching that provides adequate illumination for construction operations and traffic conditions.
1. Install and operate temporary lighting that fulfills security, protection and meets personnel Health and Safety Requirements for the execution of the work.
 2. Install exterior-yard site lighting that will provide adequate illumination for construction operations, traffic conditions, and signage visibility when the Work is being performed.
 3. Provide a portable cellular telephone for superintendents' use in making and receiving telephone calls when away from field office.

3.3 SUPPORT FACILITIES INSTALLATION

- A. General: Comply with the following:
1. Locate field offices, storage sheds, sanitary facilities, and other temporary construction and support facilities for easy access.
 2. Provide incombustible construction for offices, shops, and sheds located within construction area or within 30 feet of building lines. Comply with NFPA 241.
 3. Maintain support facilities until near Substantial Completion. Remove before Substantial Completion.
- B. Temporary Roads and Paved Areas: Construct and maintain temporary roads and paved areas adequate to support loads and to withstand exposure to traffic during construction period. Locate temporary roads and paved areas as indicated on Drawings.
1. Provide a reasonably level, graded, well-drained subgrade of satisfactory soil material, compacted to not less than 95 percent of maximum dry density in the top 6 inches
 2. Provide gravel paving course of subbase material not less than dimension indicated on drawings; roller compacted to a level, smooth, dense surface.
 3. Provide dust-control treatment that is nonpolluting and nontracking. Reapply treatment as required to minimize dust.

- C. Traffic Controls: Provide temporary traffic controls at junction of temporary roads with public roads in accordance with applicable permits. Include warning signs for public traffic and "STOP" signs for entrance onto public roads. Comply with requirements of authorities having jurisdiction.
- D. Dewatering Facilities and Drains: Comply with requirements in applicable project permits for temporary drainage and dewatering facilities and operations not directly associated with construction activities included in individual Sections. Where feasible, use same facilities. Maintain Project site, excavations, and construction free of water.
1. Dispose of rainwater in a lawful manner that will not result in flooding Project or adjoining property nor endanger permanent Work or temporary facilities.
 2. Before connection and operation of permanent drainage piping system, provide temporary drainage where roofing or similar waterproof deck construction is completed.
 3. Remove snow and ice as required to minimize accumulations.
- E. Waste Disposal Facilities: Collect waste from construction areas and elsewhere daily. Provide waste-collection containers in sizes adequate to handle waste from construction operations. Containerize and clearly label hazardous, dangerous, or unsanitary waste materials separately from other waste. Comply with Division 1 Section "Execution Requirements" for progress cleaning requirements.
1. If required by authorities having jurisdiction, provide separate containers, clearly labeled, for each type of waste material to be deposited.
 2. Develop a waste management plan for Work performed on Project. Indicate types of waste materials Project will produce and estimate quantities of each type. Provide detailed information for on-site waste storage and separation of recyclable materials. Provide information on destination of each type of waste material and means to be used to dispose of all waste materials.
- F. Storage and Fabrication Sheds: Provide sheds sized, furnished, and equipped to accommodate materials and equipment involved, including temporary utility services. Sheds may be open shelters or fully enclosed spaces within building or elsewhere on-site.
1. Construct framing, sheathing, and siding using fire-retardant-treated lumber and plywood.
 2. Paint exposed lumber and plywood with exterior-grade acrylic-latex emulsion over exterior primer.
- G. Lifts and Hoists: Provide facilities for hoisting materials and personnel. Truck cranes and similar devices used for hoisting materials are considered "tools and equipment" and not temporary facilities.

3.4 SECURITY AND PROTECTION FACILITIES INSTALLATION

- A. Environmental Protection: Provide protection, operate temporary facilities, and conduct construction in ways and by methods that comply with environmental regulations and that minimize possible air, waterway, and subsoil contamination or pollution or other undesirable effects. Avoid using tools and equipment that produce harmful noise. Restrict use of noisemaking tools and equipment to hours that will minimize complaints from persons or firms near Project site.

- B. Stormwater Control: Provide earthen embankments and similar barriers in and around excavations and subgrade construction, sufficient to prevent flooding by runoff of stormwater from heavy rains.
- C. Tree and Plant Protection: Install temporary fencing located as indicated or outside the drip line of trees to protect vegetation from construction damage. Protect tree root systems from damage, flooding, and erosion.
- D. Barricades, Warning Signs, and Lights: Comply with standards and code requirements for erecting structurally adequate barricades. Paint with appropriate colors, graphics, and warning signs to inform personnel and public of possible hazard. Where appropriate and needed, provide lighting, including flashing red or amber lights.
- E. Temporary Enclosures: Provide temporary enclosures for protection of construction, in progress and completed, from exposure, foul weather, other construction operations, and similar activities.
- F. Temporary Fire Protection: Install and maintain temporary fire-protection facilities of types needed to protect against reasonably predictable and controllable fire losses. Comply with NFPA 241.
 - 1. Provide fire extinguishers, installed on walls on mounting brackets, visible and accessible from space being served, with sign mounted above.
 - a. Field Offices: Class A stored-pressure water-type extinguishers.
 - b. Other Locations: Class ABC dry-chemical extinguishers or a combination of extinguishers of NFPA-recommended classes for exposures.
 - c. Locate fire extinguishers where convenient and effective for their intended purpose.
 - 2. Store combustible materials in containers in fire-safe locations.
 - 3. Maintain unobstructed access to fire extinguishers, fire hydrants, temporary fire-protection facilities, stairways, and other access routes for fire fighting. Prohibit smoking in hazardous fire-exposure areas.
 - 4. Supervise welding operations, combustion-type temporary heating units, and similar sources of fire ignition.
 - 5. Develop and supervise an overall fire-prevention and first-aid fire-protection program for personnel at Project site. Review needs with local fire department and establish procedures to be followed. Instruct personnel in methods and procedures. Post warnings and information.

3.5 OPERATION, TERMINATION, AND REMOVAL

- A. Supervision: Enforce strict discipline in use of temporary facilities. To minimize waste and abuse, limit availability of temporary facilities to essential and intended uses.
- B. Maintenance: Maintain facilities in good operating condition until removal. Protect from damage caused by freezing temperatures and similar elements.

1. Maintain operation of temporary enclosures, heating, cooling, humidity control, ventilation, and similar facilities on a 24-hour basis where required to achieve indicated results and to avoid possibility of damage.
 2. Prevent water-filled piping from freezing. Maintain markers for underground lines. Protect from damage during excavation operations.
- C. Termination and Removal: Unless the Construction Manager requests that it be maintained longer, remove each temporary facility when need for its service has ended, or no later than Substantial Completion. . Repair damaged Work, clean exposed surfaces, and replace construction that cannot be satisfactorily repaired.
1. Materials and facilities that constitute temporary facilities are the property of Contractor. Owner reserves right to take possession of Project identification signs.
 2. Remove temporary paving not intended for or acceptable for integration into permanent paving. Where area is intended for landscape development, remove soil and aggregate fill that do not comply with requirements for fill or subsoil. Remove materials contaminated with road oil, asphalt and other petrochemical compounds and other substances that might impair growth of plant materials or lawns. Repair or replace street paving, curbs, and sidewalks at temporary entrances, as required by authorities having jurisdiction.
 3. Comply with final cleaning requirements in Division 1 Section "Closeout Procedures."

END OF SECTION

SECTION 015700 MAINTENANCE AND PROTECTION OF TRAFFIC

PART 1 - GENERAL

1.1 SUMMARY

- A. This section specifies the requirements for maintenance and protection of Traffic during construction of the Project.
- B. General:
1. All streets and travel ways shall remain open to the passage of vehicular and pedestrian traffic during the construction period, unless prior written consent is obtained from the Construction Manager and the governing body having jurisdiction over the street or travel way.
 2. Maintenance and protection of traffic shall be provided in accordance with the Manual of Uniform Traffic Control Devices (MUTCD) and any provisions contained in the plans or the contract documents.
 3. Safe and adequate ingress and egress to and from intersecting highways, town roads, access roads, homes, adjoining properties and commercial establishments shall be provided and maintained at all times to the satisfaction of the Construction Manager.
 4. The traffic maintenance schemes shown in the MUTCD describe the minimum methods and control devices necessary. The Construction Manager may order additional devices and/or methods to meet field conditions. No additional payment will be made for additional devices ordered.
 5. The Contractor shall give the required advance notice, as indicated in the contract document or by agreement with the Construction Manager, of his proposed operations to affected police, fire, and other emergency response departments. The Contractor shall give reasonable notice of his proposed operations to owners and tenants of private properties which will be affected by the construction operations.
 6. Traffic Control Plans for work within VAOT right-of-ways has been prepared as part of the VGS ANGP – 19 V.S.A. 1111 Permit Application, and upon approval will become a part of this Contract.
- C. Submittals:
1. Prior to the start of work, the Contractor must submit any proposed changes to the traffic control plan to the Construction Manager for approval. Any changes which alters the basic concept of the plan must be approved by the Construction Manager.

PART 2 - PRODUCTS

2.1 DEVICES AND EQUIPMENT

- A. All signing, operations, safety, and directive devices shall conform to the Manual of Uniform Traffic Control Devices and the Authority having jurisdiction.
1. Delineators: Delineators shall be of the reflectorized plastic drum type.

2. Warning Signs: Advance warning signs shall be diamond shaped and have black lettering on an orange background.

PART 3 - EXECUTION

3.1 MAINTENANCE OF TRAFFIC

- A. The Contractor shall provide signs, signals, barricades, flares, lights, and all other equipment, service, and personnel necessary to regulate and protect traffic and warn of hazards. The Contractor shall remove temporary equipment and facilities when no longer required, and restore area to original or specified conditions upon removal.
- B. When crossings, obstructions, or the temporary closures of street or travelway are required, the Contractor shall provide and maintain suitable bridges, detours or other temporary measures, all of which must be to the satisfaction of the Construction Manager, for the accommodation of traffic. The duration of the operation shall be for the minimum time practical. Traffic shall be restored as soon as the street or travelway is safely passable.

3.2 WORK ZONES

- A. Work zones on opposite sides of the road shall not overlap. A work zone is defined as that area in which traffic is restricted because of construction activities, or that area which involves a drop-off within 10 feet of the edge of pavement.
- B. The Contractor shall delineate areas where there is a drop-off near the edge of the traveled way and areas on which it is unsafe to travel. The provisions for delineation shall be as approved by the Construction Manager, and the governing body having jurisdiction over the street, travelway, or site.
- C. Excavations that produce drop-offs on both sides of the traveled way at the same time shall not be permitted.
- D. Reflectorized plastic drum delineators shall be used along embankments and at other hazardous locations determined by the Construction Manager. Delineators shall remain in place until satisfactory protection is provided. Delineators shall be spaced at a distance not to exceed 50 feet, or as directed by the Construction Manager.
- E. The Contractor shall provide 1-inch steel plates to provide for traffic movement over narrow, open excavations. Excavations made for the installation of the pipes will be backfilled at the close of each day.
- F. No material is to be stored on the shoulder or within the 20-foot roadside clear area, except that which is to be placed that day.
- G. Construction equipment shall be removed from the roadside clear area of all highway pavement during the hours that the Contractor is not working. This requirement shall not be limited to the contract limits.
- H. Traffic Signals and Signs:
 1. The Contractor shall provide and operate traffic control and directional signals required to direct and maintain an orderly flow of traffic in areas affected by the Contractor's operations.

2. The Contractor shall provide traffic control and direction signs, mounted on barricades or standard posts at each change of direction of a roadway, at each crossroad, at detours, at hazardous areas, and at parking areas.
 3. The correct sequence and spacing of signs, either permanent or temporary must be maintained at all times in accordance with MUTCD unless shown otherwise on the plans. All signs, including guide signs, shall indicate actual conditions at all times and shall be covered, moved, removed, or changed immediately as ordered by the Construction Manager.
 4. In order to maintain effective traffic control, the contractor shall be responsible for the maintenance of all signs, cones, flashers, barrels, and other devices the Contractor shall ensure that they are in place and in good condition.
- I. Flag Personnel:
1. The Contractor shall provide suitably qualified and equipped flag personnel when construction operations encroach on traffic lanes. The regulation of traffic by flag personnel shall be in accordance with the requirements of the MUTCD or the Authority having jurisdiction.
- J. Flares and Lights:
1. During periods of low visibility the Contractor shall provide flares and lights to guide traffic, to clearly delineate traffic lanes, and to warn of hazardous areas. Flag personnel shall use lights in directing traffic during periods of low visibility. Illumination of critical traffic and parking areas shall be provided by the Contractor during periods of low visibility.
- K. Parking Control:
1. The Contractor shall control all Contractor related vehicular parking such that it does not interfere with public traffic and parking, access to emergency vehicles, Owner's operations, or construction operations. The Contractor shall provide temporary parking facilities for the public as construction operations dictate.
 2. The Contractor shall provide parking areas for workman's private vehicles that comply with applicable laws, regulations, codes, and ordinances. The Contractor shall ensure free vehicular access to and through the parking areas. The Contractor shall not permit parking on or adjacent to access roads or in non-designated areas.
- L. Haul Routes:
1. The Contractor shall consult with governing authorities and establish thorough fares which shall be used as haul routes and site access. The Contractor shall confine construction traffic to designated haul routes. The Contractor will be required to provide traffic control at critical points of haul routes to expedite traffic flow and minimize interference with normal public traffic. Where required by governing authorities, the Contractor shall prepare and submit traffic control plans for approval by both the Construction Manager and the governing Authority prior to commencement of work.
- M. Contractor Operations:
1. If the Construction Manager notifies the Contractor or his superintendent of any hazardous construction practices, all operations in that area shall be discontinued and immediate remedial action shall be taken to the satisfaction of the Construction Manager before work is resumed.

END OF SECTION

SECTION 017300- EXECUTION REQUIREMENTS

PART 1 - GENERAL

1.1 SUMMARY

- A. This Section includes general procedural requirements governing execution of the Work including, but not limited to, the following:
1. Construction layout.
 2. Field engineering and surveying.
 3. General installation of products.
 4. Coordination of Owner-installed products.
 5. Progress cleaning.
 6. Starting and adjusting.
 7. Protection of installed construction.
 8. Correction of the Work.

1.2 SUBMITTALS

- A. All information identified in Contract Documents.
- B. Requests for Information made by Construction Manager.
- C. Qualification Data: Sufficient information to demonstrate capabilities and experience. Include lists of completed projects with project names and addresses, names and addresses of engineers and owners, and other information specified.

1.3 QUALITY ASSURANCE

- A. Quality Assurance and Quality Control as identified in Section – Quality Requirements.

PART 2 - PRODUCTS (Not Used)

PART 3 - EXECUTION

3.1 EXAMINATION

- A. Existing Utilities: The existence and location of underground and other utilities and construction indicated as existing are not guaranteed. Before beginning sitework, investigate and verify the existence and location of underground utilities and other construction affecting the Work.
1. Before construction, verify the location and invert elevation at points of connection of sanitary sewer, storm sewer, and water-service piping; and underground electrical services.
 2. Furnish location data for work related to Project that must be performed by public utilities serving Project site.

- B. Acceptance of Conditions: Examine substrates, TWS and ATWS areas, and conditions, with Installer or Applicator present where indicated, for compliance with requirements for installation tolerances and other conditions affecting performance. Record observations. Report to the Construction Manager any unresolvable issues.
1. Written Report: Where a written report listing conditions detrimental to performance of the Work is required by other Sections, include the following:
 - a. Description of the Work.
 - b. List of detrimental conditions, including substrates.
 - c. List of unacceptable installation tolerances.
 - d. Recommended corrections.
 2. Proceed with installation only after unsatisfactory conditions have been corrected. Proceeding with the Work indicates acceptance of surfaces and conditions.

3.2 PREPARATION

- A. Existing Utility Information: Furnish information to local utility that is necessary to adjust, move, or relocate existing utility structures, utility poles, lines, services, or other utility appurtenances located in or affected by construction. Coordinate with authorities having jurisdiction.
- B. Existing Utility Interruptions: Do not interrupt utilities unless permitted, then only after arranging to provide temporary utility services according to requirements indicated:
1. Notify Construction Manager and Owner not less than 48 hours in advance of proposed utility interruptions.
 2. Do not proceed with utility interruptions without Construction Manager's and Utility's written permission.
- C. Field Measurements: Take field measurements as required to fit the Work properly. Recheck measurements before installing each product. Where portions of the Work are indicated to fit to other construction, verify dimensions of other construction by field measurements before fabrication. Coordinate fabrication/installation schedule with construction progress and work of others to avoid unnecessary delay of the Work.
- D. Space Requirements: Verify space requirements and dimensions of items shown diagrammatically on Drawings.
- E. Review of Contract Documents and Field Conditions: Immediately on discovery of the need for clarification of the Contract Documents, submit a request for information to Construction Manager. Include a detailed description of problem encountered, together with recommendations for changing the Contract Documents.

3.3 CONSTRUCTION LAYOUT

- A. Verification: Before proceeding with the Work, verify layout information shown on Drawings, in relation to the survey control and field layout. If discrepancies are discovered, notify Construction Manager promptly.

- B. General: Owner will provide project lay out using accepted surveying practices, as follows:
1. Establish benchmarks and control points to set lines and levels and elsewhere as needed to locate each element of Project.
 2. Establish dimensions within tolerances indicated. Do not scale Drawings to obtain required dimensions.
 3. Inform installers of lines and levels to which they must comply.
 4. Check the location, level and plumb, of every major element as the Work progresses.
 5. Notify Construction Manager when deviations from required lines and levels exceed allowable tolerances.
 6. Close site surveys with an error of closure equal to or less than the standard established by authorities having jurisdiction.
- C. Site Improvements: Locate and lay out site improvements, including pavements, grading, fill and topsoil placement, utility slopes, and invert elevations.
- D. Building Lines and Levels: Locate and lay out control lines and levels for structures, building foundations, column grids, and floor levels, including those required for mechanical and electrical work. Transfer survey markings and elevations for use with control lines and levels. Level foundations and piers from two or more locations.
- E. Record Log: Maintain a log of layout control work. Record deviations from required lines and levels. Include beginning and ending dates and times of surveys, weather conditions, name and duty of each survey party member, and types of instruments and tapes used. Make the log available for reference by Engineer and Construction Manager.
- F. Contractor is responsible for protecting and maintaining all construction layout information at no additional cost to the Owner.

3.4 FIELD ENGINEERING

- A. Alignment of the pipeline is depicted on the ANGP Transmission Pipeline alignment sheets and associated drawings. VGS will have the pipeline alignment staked along the centerline of the proposed pipeline. Survey stakes will be set at minimum 200-foot spacing. The Contractor is responsible for preserving and replacing all layout controls, existing survey stakes, and monuments.
- B. Identification: Owner will identify existing benchmarks and control points.
- C. Reference Points: Locate existing permanent benchmarks, control points, and similar reference points before beginning the Work. Preserve and protect permanent benchmarks and control points during construction operations.
1. Do not change or relocate existing benchmarks or control points without prior written approval of Construction Manager. Report lost or destroyed permanent benchmarks or control points promptly. Report the need to relocate permanent benchmarks or control points to and Construction Manager before proceeding.

2. Replace lost or destroyed permanent benchmarks and control points promptly. Base replacements on the original survey control points.
 3. Contractor shall install temporary markers with survey station numbers at minimum 200-foot spacing to facilitate location and progress reporting. These shall be located on the boundary of the working side of the right-of-way, with station numbers visible. Contractor shall also flag the right of way boundaries at 200 foot intervals to eliminate off right of way damage. Contractor shall maintain all temporary markers and boundary flagging throughout construction.
 4. Contractor shall replace any pipeline trench centerline markers disturbed by construction operations ahead of the trenching operation in their original location. Owner may check and adjust the location of these markers as necessary.
- D. Benchmarks: Establish and maintain permanent benchmarks on Project site, as necessary, referenced to data established by survey control points. Comply with authorities having jurisdiction for type and size of benchmark.
1. Record benchmark locations, with horizontal and vertical data, on Project Record Documents.
 2. Where the actual location or elevation of layout points cannot be marked, provide temporary reference points sufficient to locate the Work.
 3. Remove temporary reference points when no longer needed. Restore marked construction to its original condition.
- E. Certified Survey: On completion of foundation walls, major site improvements, and other work requiring field-engineering services, Owner shall prepare a certified survey showing dimensions, locations, angles, and elevations of construction and sitework.

3.5 INSTALLATION

- A. General: Locate the Work and components of the Work accurately, in correct alignment and elevation, as indicated.
- B. Comply with manufacturer's written instructions and recommendations for installing products in applications indicated.
- C. Install products at the time and under conditions that will ensure the best possible results. Maintain conditions required for product performance until Substantial Completion.
- D. Conduct construction operations so no part of the Work is subjected to damaging operations or loading in excess of that expected during normal conditions of occupancy.
- E. Anchors and Fasteners: Provide anchors and fasteners as required to anchor each component securely in place, accurately located and aligned with other portions of the Work.
- F. Hazardous Materials: Use products, cleaners, and installation materials that are not considered hazardous. Provide MSDS on all products or provide controls in accordance with proper use.

3.6 PROGRESS CLEANING

- A. General: Clean Project site and work areas daily, including common areas. Coordinate progress cleaning of joint-use areas where more than one Contractor is working with the others. Enforce requirements strictly. Dispose of materials lawfully.
1. Comply with requirements in NFPA 241 for removal of combustible waste materials and debris.
 2. Do not hold materials more than 7 days during normal weather or 3 days if the temperature is expected to rise above 80 deg F (27 deg C).
 3. Containerize hazardous and unsanitary waste materials separately from other waste. Mark containers appropriately and dispose of legally, according to regulations.
- B. Site: Maintain Project site free of waste materials and debris.
- C. Work Areas: Clean areas where work is in progress to the level of cleanliness necessary for proper execution of the Work.
1. Remove liquid spills promptly.
 2. Where dust would impair proper execution of the Work, broom-clean or vacuum the entire work area, as appropriate.
- D. Installed Work: Keep installed work clean. Clean installed surfaces according to written instructions of manufacturer or fabricator of product installed, using only cleaning materials specifically recommended. If specific cleaning materials are not recommended, use cleaning materials that are not hazardous to health or property and that will not damage exposed surfaces.
- E. Concealed Spaces: Remove debris from concealed spaces before enclosing the space.
- F. Exposed Surfaces: Clean exposed surfaces and protect as necessary to ensure freedom from damage and deterioration.
- G. Thoroughly clean piping, conduit, and similar features before applying paint or other finishing materials. Restore damaged pipe covering to its original condition.
- H. Waste Disposal: Burying or burning waste materials on-site will not be permitted. Washing waste materials down sewers or into waterways will not be permitted.
- I. During handling and installation, clean and protect construction in progress and adjoining materials already in place. Apply protective covering where required to ensure protection from damage or deterioration.
- J. Clean and provide maintenance on completed construction as frequently as necessary through the remainder of the construction period.
- K. Limiting Exposures: Supervise construction operations to assure that no part of the construction, completed or in progress, is subject to harmful, dangerous, damaging, or otherwise deleterious exposure during the construction period.

3.7 STARTING AND ADJUSTING

- A. Start equipment and operating components to confirm proper operation. Remove malfunctioning units, replace with new units, and retest.
- B. Adjust operating components for proper operation without binding. Adjust equipment for proper operation.
- C. Test each piece of equipment to verify proper operation. Test and adjust controls and safeties. Replace damaged and malfunctioning controls and equipment.
- D. Manufacturer's Field Service: If a factory-authorized service representative is required to inspect field-assembled components and equipment installation, comply with qualification requirements in Division 1 Section "Quality Requirements."

3.8 PROTECTION OF INSTALLED CONSTRUCTION

- A. Provide final protection and maintain conditions that ensure installed Work is without damage or deterioration at time of Substantial Completion.
- B. Comply with manufacturer's written instructions for temperature and relative humidity.

3.9 CORRECTION OF THE WORK

- A. Repair or remove and replace defective construction. Restore damaged substrates and finishes.
 - 1. Repairing includes replacing defective parts, refinishing damaged surfaces, touching up with matching materials, and properly adjusting operating equipment.
- B. Restore permanent facilities used during construction to their specified condition.
- C. Remove and replace damaged surfaces that are exposed to view if surfaces cannot be repaired without visible evidence of repair.
- D. Repair components that do not operate properly. Remove and replace operating components that cannot be repaired.
- E. Remove and replace chipped, scratched, and broken glass or reflective surfaces.

END OF SECTION

SECTION 017700 - CLOSEOUT PROCEDURES

PART 1 - GENERAL

1.1 SUMMARY

- A. This Section includes administrative and procedural requirements for contract closeout, including, but not limited to, the following:
 - 1. Inspection procedures.
 - 2. Project Record Documents.
 - 3. Warranties.
 - 4. Instruction of Owner's personnel.
 - 5. Final Cleaning and restoration.

1.2 SUBSTANTIAL COMPLETION

- A. Preliminary Procedures: Before requesting inspection for determining date of Substantial Completion, complete the following. List items below that are incomplete in request.
 - 1. Prepare a list of items to be completed and corrected (punch list), the value of items on the list, and reasons why the Work is not complete.
 - 2. Advise Owner of pending insurance changeover requirements.
 - 3. Submit specific warranties, workmanship bonds, maintenance service agreements, final certifications, and similar documents.
 - 4. Obtain and submit releases permitting Owner unrestricted use of the Work and access to services and utilities. Include occupancy permits, operating certificates, and similar releases.
 - 5. Prepare and submit Project Record Documents, operation and maintenance manuals, Final Completion construction photographs, damage or settlement surveys, property surveys, and similar final record information.
 - 6. Deliver tools, spare parts, extra materials, and similar items to location designated by Owner. Label with manufacturer's name and model number where applicable.
 - 7. Make final changeover of permanent locks and deliver keys to Owner. Advise Owner's personnel of changeover in security provisions.
 - 8. Complete startup testing of systems.
 - 9. Submit test records.
 - 10. Terminate and remove temporary facilities from Project site, along with mockups, construction tools, and similar elements.
 - 11. Submit changeover information related to Owner's use, operation, and maintenance.
 - 12. Complete final cleaning requirements, including touchup painting.

DRAFT - NOT FOR CONSTRUCTION

Fix footer spacing

13. Touch up and otherwise repair and restore marred exposed finishes to eliminate visual defects.
- B. Inspection: Submit a written request for inspection for Substantial Completion. On receipt of request, Construction Manager will either proceed with inspection or notify Contractor of unfulfilled requirements. Construction Manager will prepare the Certificate of Substantial Completion after inspection or will notify Contractor of items, either on Contractor's list or additional items identified by Construction Manager, that must be completed or corrected before certificate will be issued.
 1. Reinspection: Request reinspection when the Work identified in previous inspections as incomplete is completed or corrected.
 2. Results of completed inspection will form the basis of requirements for Final Completion.

1.3 FINAL COMPLETION

- A. Preliminary Procedures: Before requesting final inspection for determining date of Final Completion, complete the following:
 1. Submit a final Application for Payment according to Division 1 Section "Payment Procedures."
 2. Submit certified copy of Construction Manager's Substantial Completion inspection list of items to be completed or corrected (punch list), endorsed and dated by Construction Manager. The certified copy of the list shall state that each item has been completed or otherwise resolved for acceptance.
 3. Submit evidence of final, continuing insurance coverage complying with insurance requirements.
 4. Instruct Owner's personnel in operation, adjustment, and maintenance of products, equipment, and systems.
- B. Inspection: Submit a written request for final inspection for acceptance. On receipt of request, Construction Manager will either proceed with inspection or notify Contractor of unfulfilled requirements. Engineer will prepare a final Certificate for Payment after inspection or will notify Contractor of construction that must be completed or corrected before certificate will be issued.
 1. Reinspection: Request reinspection when the Work identified in previous inspections as incomplete is completed or corrected.

1.4 PROJECT RECORD DOCUMENTS

- A. General: Do not use Project Record Documents for construction purposes. Protect Project Record Documents from deterioration and loss. Provide access to Project Record Documents for Construction Manager's reference during normal working hours.
- B. Record Specifications: Submit one copy of Project's Specifications, including addenda and contract modifications. Mark copy to indicate the actual product installation where installation varies from that indicated in Specifications, addenda, and contract modifications.
 1. Give particular attention to information on concealed products and installations that cannot be readily identified and recorded later.

2. Mark copy with the proprietary name and model number of products, materials, and equipment furnished, including substitutions and product options selected.
 3. Note related Change Orders, Record Drawings, and Product Data, where applicable.
- C. Record Product Data: Submit one copy of each Product Data submittal. Mark one set to indicate the actual product installation where installation varies substantially from that indicated in Product Data.
1. Give particular attention to information on concealed products and installations that cannot be readily identified and recorded later.
 2. Include significant changes in the product delivered to Project site and changes in manufacturer's written instructions for installation.
 3. Note related Change Orders, Record Drawings, and Record Specifications, where applicable.
- D. Miscellaneous Record Submittals: Assemble miscellaneous records required by other Specification Sections for miscellaneous record keeping and submittal in connection with actual performance of the Work. Bind or file miscellaneous records and identify each, ready for continued use and reference.
- E. Provide Construction Manager and Owner with an electronic (PDF) copy of all record documents on collaboration website.

1.5 OPERATION AND MAINTENANCE MANUALS

- A. Assemble a complete set of operation and maintenance data indicating the operation and maintenance of each system, subsystem, and piece of equipment not part of a system. Include operation and maintenance data required in individual Specification Sections and as follows:
1. Operation Data:
 - a. Emergency instructions and procedures.
 - b. System, subsystem, and equipment descriptions, including operating standards.
 - c. Operating procedures, including startup, shutdown, seasonal, and weekend operations.
 - d. Description of controls and sequence of operations.
 - e. Piping diagrams.
 2. Maintenance Data:
 - a. Manufacturer's information, including list of spare parts.
 - b. Name, address, and telephone number of Installer or supplier.
 - c. Maintenance procedures.
 - d. Maintenance and service schedules for preventive and routine maintenance.
 - e. Maintenance record forms.
 - f. Sources of spare parts and maintenance materials.
 - g. Copies of maintenance service agreements.
 - h. Copies of warranties and bonds.

- B. Organize operation and maintenance manuals into suitable sets of manageable size. Bind and index data in heavy-duty, 3-ring, vinyl-covered, loose-leaf binders, in thickness necessary to accommodate contents, with pocket inside the covers to receive folded oversized sheets. Identify each binder on front and spine with the printed title "OPERATION AND MAINTENANCE MANUAL," Project name, and subject matter of contents. Also include a PDF file with the applicable information.

1.6 WARRANTIES

- A. Submittal Time: Submit written warranties on request of Engineer for designated portions of the Work where commencement of warranties other than date of Substantial Completion is indicated.
- B. Organize warranty documents into an orderly sequence based on the table of contents of the Project Manual.
 - 1. Bind warranties and bonds in heavy-duty, 3-ring, "D" ring, vinyl-covered, loose-leaf binders, thickness as necessary to accommodate contents, and sized to receive 8-1/2-by-11-inch paper.
 - 2. Provide heavy paper dividers with plastic-covered tabs for each separate warranty. Mark tab to identify the product or installation. Provide a typed description of the product or installation, including the name of the product and the name, address, and telephone number of Installer.
 - 3. Identify each binder on the front and spine with the typed or printed title "WARRANTIES," Project name, and name of Contractor.
- C. Provide additional copies of each warranty to include in operation and maintenance manuals.

PART 2 - PRODUCTS

2.1 MATERIALS

- A. Cleaning Agents: Use cleaning materials and agents recommended by manufacturer or fabricator of the surface to be cleaned. Do not use cleaning agents that are potentially hazardous to health or property or that might damage finished surfaces.

PART 3 - EXECUTION

3.1 DEMONSTRATION AND TRAINING

- A. Instruction: Instruct Owner's personnel to adjust, operate, and maintain systems, subsystems, and equipment not part of a system.
 - 1. Provide instructors experienced in operation and maintenance procedures.
 - 2. Provide instruction at mutually agreed-on times. For equipment that requires seasonal operation, provide similar instruction at the start of each season.
 - 3. Schedule training with Owner through Construction Manager, with at least 7 days advance notice.

4. Coordinate instructors, including providing notification of dates, times, length of instruction, and course content.
- B. Program Structure: Develop an instruction program that includes individual training modules for each system and equipment not part of a system, as required by individual Specification Sections. For each training module, develop a learning objective and teaching outline. Include instruction for the following:
1. System design and operational philosophy.
 2. Review of documentation.
 3. Operations.
 4. Adjustments.
 5. Troubleshooting.
 6. Maintenance.
 7. Repair.

3.2 FINAL CLEANING

- A. General: Provide final cleaning. Conduct cleaning and waste-removal operations to comply with local laws and ordinances and Federal and local environmental and antipollution regulations.
- B. Cleaning: Employ experienced workers for final cleaning. Clean each surface or unit to condition expected in an average industrial building cleaning and maintenance program. Comply with manufacturer's written instructions.
1. Complete the following cleaning operations before requesting inspection for certification of Substantial Completion for entire Project or for a portion of Project:
 - a. Clean Project site, yard, and grounds, in areas disturbed by construction activities, including landscape development areas, of rubbish, waste material, litter, and other foreign substances.
 - b. Sweep paved areas broom clean. Remove petrochemical spills, stains, and other foreign deposits.
 - c. Rake grounds that are neither planted nor paved to a smooth, even-textured surface.
 - d. Remove tools, construction equipment, machinery, and surplus material from Project site.
 - e. Remove snow and ice, where applicable, to provide safe access.
 - f. Clean exposed exterior and interior hard-surfaced finishes to a dirt-free condition, free of stains, films, and similar foreign substances. Avoid disturbing natural weathering of exterior surfaces. Restore reflective surfaces to their original condition.
 - g. Remove debris and surface dust from limited access spaces, including roofs, plenums, shafts, trenches, equipment vaults, manholes, attics, and similar spaces.
 - h. Sweep concrete floors broom clean in unoccupied spaces.
 - i. Remove labels that are not permanent.

- j. Touch up and otherwise repair and restore marred, exposed finishes and surfaces. Replace finishes and surfaces that cannot be satisfactorily repaired or restored or that already show evidence of repair or restoration.
 - 1) Do not paint over "UL" and similar labels, including mechanical and electrical nameplates.
 - k. Wipe surfaces of mechanical and electrical equipment, and similar equipment. Remove excess lubrication, paint and mortar droppings, and other foreign substances.
 - l. Replace parts subject to unusual operating conditions.
 - m. Clean exposed surfaces of diffusers, registers, and grills.
 - n. Clean light fixtures, lamps, globes, and reflectors to function with full efficiency. Replace burned-out bulbs, and those noticeably dimmed by hours of use, and defective and noisy starters in fluorescent and mercury vapor fixtures to comply with requirements for new fixtures.
 - o. Leave Project clean and ready for operation.
- C. Comply with safety standards for cleaning. Do not burn waste materials. Do not bury debris or excess materials on Owner's property. Do not discharge volatile, harmful, or dangerous materials into drainage systems. Remove waste materials from Project site and dispose of lawfully.

END OF SECTION

SECTION 017839 - PROJECT RECORD DOCUMENTS

PART 1 - GENERAL

1.1 SUMMARY

- A. This Section includes administrative and procedural requirements for Project Record Documents, including the following:
 - 1. Record Drawings.
 - 2. Record Specifications.
 - 3. Record Product Data.
 - 4. Record Documentation specified elsewhere with this Specification
 - 5. Record Samples.

1.2 SUBMITTALS

- A. Record Drawings: Owner's representative shall bear the responsibility of the Record Drawings. Contractor shall assist and coordinate with the Owner, as necessary, to complete this task.
- B. Record Specifications: Submit 1 copy of Project's Specifications, including addenda and contract modifications.
- C. Record Product Data: Submit 1 copy of each approved Product Data submittal.
 - 1. Where Record Product Data is required as part of operation and maintenance manuals, submit marked-up Product Data as an insert in the manual instead of submittal as Record Product Data.
- D. Record Documentation: See subsequent specification Sections for task specific documentation requirements.

PART 2 - PRODUCTS

2.1 AS-BUILT INFORMATION TO BE COLLECTED

- A. Contractor will provide labor and equipment, when necessary, to assist the Owner with the collection of as-built information to accurately document the installation of the pipeline. All as-built locations will be with reference to the actual distance in feet along the top of pipe.
- B. Contractor shall not cover up any piping before Owner has recorded as-built data.
- C. Contractor shall provide VGS with marked-up drawings of any changes to dimensions or configuration of fabricated components. Contractor shall also provide VGS with all original hydrostatic test records, including yield plots, charts, limits of each mainline test section, and the minimum and maximum test pressures realized for each test or test section

2.2 RECORD DRAWINGS

- A. Record Prints: Owner shall bear the responsibility of Record Prints.
- B. Record CAD Drawings: Owner shall bear the responsibility of Record CAD Drawings.

2.3 RECORD SPECIFICATIONS

- A. Preparation: Mark Specifications to indicate the actual product installation where installation varies from that indicated in Specifications, addenda, and contract modifications.
 - 1. Give particular attention to information on concealed products and installations that cannot be readily identified and recorded later.
 - 2. Mark copy with the proprietary name and model number of products, materials, and equipment furnished, including substitutions and product options selected.
 - 3. Record the name of the manufacturer, supplier, installer, and other information requested by task Specification to provide a record of selections made.
 - 4. Note related Change Orders, Record Drawings, and Product Data where applicable.

2.4 RECORD PROJECT DATA

- A. Preparation: Mark Product Data to indicate the actual product installation where installation varies substantially from that indicated in Product Data submittal.
 - 1. Give particular attention to information on concealed products and installations that cannot be readily identified and recorded later.
 - 2. Include significant changes in the product delivered to Project site and changes in manufacturer's written instructions for installation.
 - 3. Note related Change Orders, Record Drawings, and Product Data where applicable.

2.5 MISCELLANEOUS RECORD SUBMITTALS

- A. Assemble miscellaneous records required by other Specification Sections for miscellaneous record keeping and submittal in connection with actual performance of the Work. Bind or file miscellaneous records and identify each, ready for continued use and reference.

PART 3 - EXECUTION

3.1 RECORDING AND MAINTENANCE

- A. Recording: Maintain one copy of each submittal during the construction period for Project Record Document purposes. Post changes and modifications to Project Record Documents as they occur; do not wait until the end of Project.
- B. Maintenance of Record Documents: Store Record Documents in the field office apart from the Contract Documents used for construction. Do not use Project Record Documents for construction purposes. Maintain Record Documents in good order and in a clean, dry, legible condition, protected from deterioration and loss. Provide access to Project Record Documents for Owner, Owner Consultants, and Construction Manager's reference during normal working hours.
- C. Post Record Documents on project collaboration website.

END OF SECTION

SECTION 023219 EXPLORATORY EXCAVATION

PART 1 - GENERAL

1.1 SUMMARY

- A. This section includes exploratory excavations for the purpose of verifying the exact locations of underground utilities, structures, and other subsurface conditions.

1.2 SUBMITTALS

- A. Sketches: Submit a sketch showing the location of the subsurface features which were uncovered in the test pit, including the following information:
 1. horizontal location of the subsurface feature relative to three individual surface features.
 2. depth of feature below ground surface.
 3. diameter, type, material, and condition of pipe or conduit.
 4. orientation of pipe, conduit or structure relative to other site features.
 5. other pertinent dimensions.
 6. exploratory excavation identification number.
 7. discrepancies from design plan

1.3 JOB CONDITIONS

- A. Perform exploratory excavations only within the limits of the work, easements and rights of way.
- B. Excavate exploratory excavations with care to avoid damage to structures and utilities. Excavate by hand if necessary. Promptly repair any damaged utilities and structures at no cost to the Owner.

PART 2 - PRODUCTS (Not Applicable)

PART 3 - EXECUTION

3.1 GENERAL

- A. Exploratory excavations shall be performed in advance of construction, where necessary, at the locations shown on the Drawings, or where directed by the Engineer to, determine the exact location of all pipes, conduits, duct, or other interfering structures in both horizontal and vertical locations. Excavate to the depth and width necessary to accurately determine the locations of the utilities of interest.
- B. Upon satisfactory execution of the required exploratory excavations the Engineer shall adjust pipe elevations, alignment or design he feels necessary to minimize interferences.
- C. Backfill exploratory excavations in accordance with Section "Trenching and Backfilling"
- D. Exploratory excavations performed in areas to be further disturbed shall be graded for temporarily traffic or use.
- E. Exploratory Excavations performed in areas not to be further disturbed shall be restored to pre construction conditions.

END OF SECTION

SECTION 099000 MAINLINE VALVE ASSEMBLY PAINTING & CORROSION COATING

PART 1 - GENERAL

1.1 WORK TO BE DONE

- A. Furnish all labor, materials, scaffolding, tools, and equipment necessary to complete the painting and finishing requirements of the MLV assemblies.
- B. Included in the painting work are all MLV assemblies required for the project, including the following parts of each assembly:
 - 1. Above Grade Coatings
 - a. Above grade piping, valves, fittings, support steel and miscellaneous steel structures.
 - 2. Below Grade Coatings
 - a. Below grade piping, valves and fittings, support steel and miscellaneous steel structures
 - b. All below ground field joints
 - 3. Transition Coatings
 - a. All transitions from below to above ground piping.
- C. The work shall include cleaning and surface preparation, supply and application of primer, if required, supply and application of top coating and the supply of all consumable materials required for performing and completing the work.

1.2 RELATED WORK SPECIFIED IN OTHER SECTIONS

- A. Structural and Miscellaneous Steel primed and finish painted.

1.3 SURFACE CONDITION OF RECEIVED MATERIALS

- A. For equipment supplied and installed under this contract it is the Contractor's responsibility to ensure that the equipment is suitably primed, if required, and final painted after installation.
- B. All above ground piping will be received unpainted with a thin layer of mill applied lacquer.

PART 2 - PRODUCTS

2.1 MATERIALS

- A. Below Ground Coatings:
 - 1. Coatings shall be fusion bonded epoxy (FBE), manufactured by 3M or equal. Product shall be:
 - a. Scotchkote 6233, 206N or equal – 14 mils cured film thickness minimum
 - b. Field Joints on Below Ground Piping:

- c. Coating shall be Canusa HBE-95 or equal. – 20 mils dry film thickness (DFT) minimum
 - d. Pipe and Fittings in Air / Soil Transitions (12” Above and Below Grade):
 - e. Coating shall be Carboline Bitumastic 300M or equal - 14 to 16 mils DFT.
 - f. Carboline Bitumastic should be applied in two coats to minimize both dry time and excessive film application.
- B. Above Ground Coatings:
- 1. Coatings shall be manufactured by PPG Amercoat or equal. Coatings shall be:
 - a. Primer coat: Amerlock 2 or Amerlock 400 – 3 to 4 mils thick DFT
 - b. Second coat: Amerlock 2 or Amerlock 200 – 3 to 4 mils thick DFT
 - c. Top Coat: Amercoat 450 Series – 3 to 4 mils thick DFT
 - 2. Coating shall be 9 to 12 mils DFT overall.
 - a. Amerlock 2/400 should be applied in two coats to minimize both dry time and excessive film thickness application.

2.2 GENERAL

- A. All materials shall be delivered in unopened containers as packed by the Manufacturer. Each container shall bear the Manufacturer's standard label for the catalog item as approved showing trade name and number, formula, and directions for use. Containers shall not be opened until contents are to be used.
- B. No coating shall be thinned more than specifically recommended in the Manufacturer's printed directions and thinner used shall be the highest type of those recommended. No coating ready prepared for use shall be thinned without the approval of the Company. No driers shall be added at the job unless approved by the Company.
- C. All auxiliary materials shall be pure, of highest quality, and approved by the Company. Such materials shall bear identifying labels on the containers.

PART 3 - EXECUTION

3.1 GENERAL

- A. All coatings shall be applied as per the Manufacturer's printed instructions by brush or roller unless spray application is specifically named as acceptable in the description of required treatment, when air or airless spray shall be acceptable.
- B. Coatings shall be thoroughly stirred and kept at a uniform consistency during application.
- C. No work shall be done on damp surfaces unless printed instructions on label so recommend for the particular coating being used.
- D. Exterior painting shall not be done during or immediately following rainy or frosty weather or when the temperature is below 50°F or likely to drop to freezing. The application of treatments while

surfaces are exposed to hot sun or when temperature is above 908F or likely to be during the drying period shall be avoided.

- E. All work shall be done by skilled mechanics in a workmanlike manner; all coats flowed on or brushed out to a uniform film. Completed work shall be free of runs, sags, blocked angles, raised grain, and all other evidence of poor or careless workmanship.
- F. Allow sufficient time before recoating to ensure proper drying of the preceding coat.
- G. For enamel finishes on metal of shop-primed surfaces sand original surface between coats with fine sandpaper and remove all resulting grit and dust before application of each coat.
- H. Raised face surfaces of flanges shall be protected from blasting medium and paint.

3.2 SURFACE PREPARATION

- A. Prior to all surface preparation, Contractor shall protect all gasket surfaces, flange faces, valve stems, nameplates, pressure gauges, instrument cases, gauge glasses, electrical conduit and fixtures, instrument tubing, aids to navigation and all previously installed and coated equipment, including galvanized equipment and all specialty items.
- B. Where practical, electrical cable and instrument tubing will be installed after blasting and coating has been completed. During all blasting operations, Contractor shall exercise caution and employ masks, shields, etc. to assure that coated surfaces adjacent to the blast area are protected from overblast damage by stray or rebounding blast particles.
- C. Prior to all surface preparation, all surfaces shall be cleaned as necessary to remove oil, grease, dirt, salts, and other foreign matter, in accordance with SSPC-SP1, "Solvent Cleaning". A biodegradable water-soluble cleaner such as PPG Amercoat Prep 88, or approved equal, shall be used, followed by a fresh water wash with a minimum of 3000 psi. Surfaces to be coated shall be tested for chloride contamination prior to abrasive blasting or surface preparation using the CHLOR*TEST™ test kit or equivalent.
- D. All surfaces shall be blasted to a "near-white metal" blast cleaned surface finish as per NACE 2/SSPC-SP10/ ISO SA2.5 and will demonstrate an angular anchor pattern of at least 1.5 to 4.0 mils peak to peak. Coater shall strive to have an anchor pattern of 3.0 to 3.5 mils peak to peak.
- E. Mechanical cleaning in accordance with SSPC-SP2, SSPC-SP3 or SSPC-SP11 and solvent cleaning in accordance with SSPC-SP1 may be required separately or in conjunction with each other when blasting cannot achieve a near-white metal surface or when blasting will damage fragile components
- F. The abrasive may be coal slag, refractory slag, garnet, aluminum oxide or flint, sized to produce the required anchor profile and graded to be free from clay, silt or other matter likely to become embedded in the steel surface.
- G. Blast cleaning operations will not be conducted on surfaces that will be wet after blasting and before coating, when the surfaces are less than 5°F (30C) above dew point as measured by a sling psychrometer or digital hygrometer, or when the relative humidity of the air is greater than 85% without permission of Company. Paint manufacturer's alternate recommendations for conditions for blasting may be acceptable, with Company approval.
- H. It is desired that outdoor abrasive blasting be done during daylight hours, unless the blasting is done inside humidity and temperature controlled blasting booths/buildings. If outdoor blasting is allowed

during the night, the surface will be swept clean and bright the next morning with fresh, light blasting to provide a "white" blasted surface.

- I. Blasting will be done in an area removed from coating operations and freshly coated surfaces to prevent contamination. Contaminated coatings will be reblasted by Contractor to bare metal and re-applied as originally specified.
- J. After blasting, Contractor will thoroughly clean all blast grit and dust from both internal and external surfaces, including from crevices, recesses, etc.

3.3 COATING APPLICATION

- A. Blast-cleaned surfaces will be coated during the same day as blasting and at least one hour prior to sundown of that day and also before any rusting occurs. A minimum of 3 inches around edges of blasted areas will be left unprimed. Blasting will continue a minimum of 1-inch into adjoining coated surface. Any blast-cleaned surfaces that are not primed and are wet by rain or moisture will be re-blasted prior to application of primer.
- B. The coating film thickness is specified in Section 2.0 and is subject to inspection by the Company Inspector.
- C. No coating will be placed on or within 3 inches of edges prepared for field welds. Succeeding coats of paint will be stopped a minimum of 3 inches from the edge of the previous coat at the field weld location (i.e. primer coat stops 3 inches from field weld, intermediate coat stops 6 inches from field weld, etc.).
- D. The finished job will not contain sags, runs, wrinkles, spots, blisters or other application flaws. Holidays in the final coat at edges, corners, welds and inaccessible areas may be repaired by spraying or hand brushing an additional layer of top coat provided excessive buildup does not occur.
- E. The coatings described in this specification may contain flammable solvents. The vapor from these solvents may be harmful and cause skin and eye irritation. The resinous components of the primers and laminating resin may cause serious delay dermatitis. Employees involved in coating work will be provided with breathing apparatus, eye and skin protection by the Contractor as necessary.
- F. Succeeding coats of paint will be of colors that contrast to the color of the previous coat. Contractor will verify the finish coat color with Company prior to the initiation of material procurement.

3.4 STEELWORK

- A. Note that all steelwork is to be sandblasted before applying paint.

3.5 PROTECTION AND SURFACES NOT TO BE PAINTED

- A. The Contractor shall use tarpaulins, drops, and coverings as much as possible to protect floors, equipment, etc., from over-spray, spatter, droppings, etc.
- B. The following are not to be painted:
 - 1. Nameplates, tags, or labels.
 - 2. Machined surfaces.
 - 3. Valve stems (remove handles and paint separately).
 - 4. Swagelok or other compression fittings.
 - 5. Lubrication points.
 - 6. Pivot points involving mechanical movement.

3.6 CLEANING UP AND REPAINTING

- A. The Contractor shall remove all paint where it has been spilled, splashed, or spattered on surfaces.
- B. The Contractor shall touch up or repaint, as required by the Company all painted surfaces that are marred, marked, chipped, spalled, defaced, or deficient in any way before it is turned over to the Company.

3.7 REPAIRS TO COATINGS

A. Below Ground Coatings:

- 1. Grinding or filing shall prepare defective and/or damaged coating including pinholes with a flat file. The surface shall be abraded or "feathered" with a fine sand paper or emery cloth.
- 2. Catalyzed Epoxy Patching Compound shall be applied to prepared surface or holidays and/or defective or damaged coating, excluding pinholes in accordance with the manufacturer's recommendations to attain a uniform minimum thickness of 25 mils. Pipe with unacceptable coating, excessively low mils (thickness), separation of bond and/or holidays shall be completely reblasted to NACE Near-White finish and recoated as bare pipe. Hot melt patch stick shall be used for pinholes up to 1/4" diameter.
- 3. After repairs, pipe shall be re-inspected with an electrical holiday detector set at the appropriate voltage.

B. Above Ground Coatings:

- 1. Coating damage shall be repaired as follows:
 - a. Top coat damaged, but base coat undamaged: Repair by removing damaged coating with 3M Clean-N-Strip, abrasive cloth, or other means acceptable to Company (wire brushing will not be acceptable), feather edges of adjacent coated surfaces and applying top coat as specified.
 - b. Coating damaged to base metal: Repair by blasting and/or mechanical cleaning of the damaged area to NACE 2/SSPC-SP10/ISO Sa2.5 Near White Metal, feather adjoining paint surfaces with grit paper to provide a smooth surface transition and apply the coating system as specified in Section 2.0.
 - c. Care will be taken to avoid damaging the coatings surrounding repaired areas and to assure complete tie-in of the coating with surrounding area.

3.8 INSPECTION

- A. Coating application in accordance with this procedure shall be subject to inspection by Company Inspector at all times.
- B. Company inspector or his representative shall have access to all work while being performed.
- C. Contractor will provide and utilize wet and dry film thickness, temperature and humidity gauges as required by the performance of the work. Paint foreman shall inspect and monitor the work of painters and blasters under his direction. Daily painting logs and inspection reports shall be kept by the Contractor. Replica tape of surface profile shall be attached to inspection report.

- D. Contractor will maintain all necessary measuring and test equipment in good working order with up to date calibration records that are available for Company inspector's review. Magnetic Dry film thickness (DFT) gauges will be calibrated using either test blocks bearing nonmagnetic coatings that are traceable to a known standard or plastic shims provided by maker of electronic DFT gauges.
- E. Work shall be rejected because of poor workmanship. Poor workmanship is defined as, but not limited to improper surface preparation, inadequate drying or curing, excessive paint build-up, dirt or dust inclusions, overspray, pinholes, runs and sags or inadequate film build. Rejected work will be repaired as originally specified in this specification, at no additional cost to Company.

3.9 FUSION BONDED EPOXY COATING SPECIFIC REQUIREMENTS

- A. Pipe shall be uniformly preheated to a temperature range of 450°F to 475°F. Temperatures shall be monitored by means of suitable temperature indicating devices. The duration of preheated temperature shall be kept to the absolute minimum required for proper application. Temperatures shall comply with the manufactures recommendations but not to exceed 500°F. Pipe that is "blued" in the heating operation shall be rejected and replaced at the Coater's expense.
- B. External pipe coating shall be electrostatically sprayed.
- C. Sufficient "Gel" time shall be allowed for liquefying powder, wetting of pipe and flow out followed by sufficient "Cure" time prior to quenching or forced cooling. "Gel" and "Cure" times shall vary with each powder and manufacturer's recommendation. Therefore, the manufacturer's recommendation shall be followed.

END OF SECTION

DRAFT - NOT FOR CONSTRUCTION

SECTION 130000 MINIMUM REQUIREMENTS FOR PIPELINE CONSTRUCTION PARALLELING
OVERHEAD ELECTRIC LINES

PART 1 - GENERAL

1.1 MINIMUM REQUIREMENTS FOR PIPELINE CONSTRUCTION PARALLELING OVERHEAD
ELECTRIC LINES

- A. This construction specification applies to pipeline construction that parallels overhead high voltage electric transmission lines and represents minimum requirements only.
- B. The purpose of this specification is to cover the procedures and construction techniques which must be used during the construction period to reduce potentials on the pipe and construction equipment to a level less than 15 volts Root Mean Square (RMS) measured between the structure and ground. This is measured using a digital voltmeter.
- C. This specification is not all inclusive and is intended to remind the installer of the potential hazards which may be associated with pipeline construction in the vicinity of induced voltage, fault current, and contact to high voltage electric transmission lines.
- D. The Designer should review the project and initiate additional requirements deemed necessary to ensure the safety of persons and property affected thereby. The company shall furnish any special materials required to comply with this section. Consult with the company Electrical Transmission & Distribution Engineering for specific applications and requirements.

1.2 REFERENCES

- A. National Electric Safety Code (NESC)
- B. Occupational Safety and Health Administration (OSHA)

PART 2 - PRODUCTS (NOT USED)

PART 3 - EXECUTION

3.1 STEEL PIPE INSTALLATIONS PARALLELING HIGH VOLTAGE ELECTRIC LINES

- A. When exposed metallic piping is run parallel to overhead A.C. electric lines, the pipe is subject to induced voltages and currents that are the result of electromagnetic, electrostatic and resistive coupling.
- B. Induced voltages and currents may cause coating damage as well as damage to cathodic protection and electronic monitoring equipment.
- C. Induced voltages and current can be hazardous to personnel working on the pipeline during the construction period when long sections of pipe are exposed above ground. Lightning and faults on the transmission line can be especially dangerous.

3.2 ELECTRICAL SAFETY

- A. The contractor will furnish a responsible person that can understand and follow the Technical Specifications and Electrical Safety required for the specific project. The responsible person for electrical safety must be approved by the Owner.
1. The person in charge of electrical safety shall:
- a. Assure that all electrical safety requirements and devices are fully understood by all members of the construction forces.
 - b. Be fully aware of proper grounding procedures and with the dangers associated with electromagnetic and electrostatic couplings, resistive coupling, ground fault current discharge, lightning, etc.
 - c. Know the proper OSHA and NESC safeguards for the construction equipment being used related to the company's "limit of approach" regulations to the specific overhead transmission circuits that will be paralleled.
 - d. Have the necessary instrumentation, equipment and authority to implement and maintain safe working conditions.
 - e. Assure all safety devices and practices are properly employed during all periods of construction activity in the proximity of electric overhead transmission systems. This includes the choice of the appropriate rubber gloves for the situation.
 - f. Communicate at least daily with the dispatcher controlling the involved electric lines to ascertain any scheduled changes in loading, outages and switching operations and to notify of work on their Right-of-Way.

3.3 EQUIPMENT SAFETY

- A. Each piece of equipment utilized to handle pipe in any way such as unloading, picking up, transporting, bending or setting-in shall be grounded and shall be equipped with a cable assembly capable of grounding the sections of pipe to the piece of equipment handling that pipe.
- B. Before any section of pipe is picked up or moved in any way, the ground shall be completed between the section of pipe and the equipment moving that pipe. "Setting-In" booms shall be equipped with ground cable and the ground must be maintained at least until the stringer bead is completed. The ground connection on cranes shall be also made to the upper rotating structure supporting the boom.
- C. Pipe shall be unloaded from stringing trucks by a side boom equipped with grounding cable as described above. A ground shall be completed between all sections of pipe to be unloaded and the side boom before unloading cables or slings are attached to the pipe.

3.4 GROUNDING

- A. Each continuous segment of pipeline being worked on should be grounded to at least two separate points. This grounding should consist of one of the following alternatives:

- B. Grounding should be established by driving one or more ground rods to at least a four-foot depth and connecting these ground rods to each other and the pipeline with a #2 A.W.G. stranded copper cable. Suitable connectors should be utilized to connect the #2 A.W.G. cable to the individual ground rods and to the pipeline. No ground connections should be removed without the knowledge and concurrence of the person responsible for electric safety.
- C. Should sub-surface conditions prohibit the driving of ground rods, temporary grounding can be established with one or more ground rods, conduits of aluminum foil installed horizontally and covered with a minimum 4 inches of dirt. The segment of the pipeline being worked on should be bonded to the temporary grounding. This bond should consist of an insulated #2 A.W.G. jumper cable. The grounding cable should first be securely attached to the temporary grounding and then attached to the pipeline. Removal should be in reverse order.
- D. It is of the utmost importance that the person making or breaking the connection at the ground rod connection not "bridge the gap" between the ground rod and bond clamp.
- E. When installing or removing a grounding or bonding facility, personnel shall wear the class of rubber insulating gloves selected by the person responsible for electrical safety. The following procedures for making and breaking grounding connections shall be strictly adhered to:
1. Using Jumper Cable with End Clamps
 - a. Making grounding connections
 - 1) Establish temporary grounds (ground rods, bare casings, other appropriate ground).
 - 2) Using jumper cable with end clamps, connect one end clamp to the temporary ground.
 - 3) Using rubber gloves, connect the other end clamp to the structure to be grounded.
 - b. Disconnecting grounding connections
 - 1) Using rubber gloves, disconnect the clamp attached to the structure end.
 - 2) Disconnect the clamp connected to the temporary ground.
 2. Using Clamp Around the Pipe and Jumper Cable with End Clamps
 - a. Making ground connections
 - 1) Establish temporary ground (ground rods, bare casing, other appropriate ground).
 - 2) Using rubber gloves, connect grounding clamp around the pipe.
 - 3) Connect one end of the grounding cable to the temporary ground.
 - 4) Using rubber gloves, connect the other end of the grounding cable to the grounding clamp around the pipe.

- b. Disconnecting grounding connections
- 1) Using rubber gloves, disconnect the grounding cable from the grounding clamp around the pipe.
 - 2) Using rubber gloves, disconnect the grounding clamp around the pipe.
 - 3) Disconnect the grounding cable from the temporary ground.
 - 4) Proper work procedures related to electrical safety shall be established for all construction activities associated with this project.
- F. The person in charge of electrical safety shall check the integrity of each connection by measuring the resistance from a near point on the copper cable to the ground rod or pipeline steel using a suitable Ohm Meter. A good electrical connection will have a resistance of 0.1 Ohm or less.
- G. Pipe shall be hauled to the right-of-way and stored in stacks of ten sections or less. Each section of pipe in the stack shall be grounded with a 5/8" min. diameter ground rod driven into the ground at least four (4) feet. All sections in one stack shall be grounded together. This ground shall be maintained until each individual section of pipe has been removed from the stack.
- H. When grounding sections of pipe, the ground rod shall be driven and the grounding cable connected to the ground rod first. The grounding cable shall then be connected to the pipe. Cables used for temporary grounding attachments shall have good mechanical strength as well as high conductivity. The cable shall be single conductor #2 A.W.G. stranded copper, cable or equivalent. Cable attachments to temporary grounding systems shall be made by a method that assures good electrical contact while applying firm pressure to the pipe metal. This method of attachment should have a current carrying capacity of at least 200 amperes. When removing grounding cable, the cable shall be removed from the pipe or equipment first and then from the ground rod.
- I. All grounding attachments and removals shall be made by or under the direct supervision of the person responsible for electrical safety.
- J. Temporary ground connections should be made by electrically connecting the pipeline to each casing. Prior to the installation of the cathodic protection test leads, a bond should be installed using an insulated #2 A.W.G. jumper cable with suitable clamps. Connection shall be made first to the casing and then to the pipe. Removal of bond shall be made on reverse order.
- K. If electrolytic grounding cells are to be installed between the pipe and casing as part of the final installation, the bonds shall not be removed until the grounding cells are installed.
- L. Before any casing-pipeline temporary bond is removed, the person in charge of electrical safety shall determine that all permanent test wire connections to the pipeline and casing are intact. This shall be done by measuring the potential of the wire to a close copper-sulfate reference electrode using a suitable high resistance volt-meter. A wire connection with good metallic contact will show a potential of from 0.3 to 0.7 volt. A broken or disconnected wire connection will show a potential of 0.2 volt or less.
- M. Insulating joints shall be installed with a bond cable shorting out the insulating material. This bond cable shall remain in place until the insulating joint has been welded into the pipeline and a

grounding cell has been connected across the insulating flange. The grounding cell with test station must be in service and the bond cable removed before the insulating joint is buried.

1. Each person coming in contact with the pipeline during construction should do so only when:
 - a. Using rubber-insulating gloves. The person in charge of electrical safety should be in charge of insuring that all rubber-insulating gloves are kept in good insulating condition by following accepted test procedures. All gloves that are damaged (punctured, ripped, torn, etc.) shall be immediately replaced.
 - b. Standing on a grounding mat that is electrically connected to the pipeline at two separate locations. The grounding mat could consist of a copper weld wire mesh of #8 A.W.G. wire with a 4" x 4" mesh spacing. The mat should be electrically connected to the pipeline through a minimum #2 A.W.G. insulated jumper cables thermo welded to the mat and connected to the pipe using suitable clamps.
- N. Temporary gradient control mats shall extend a minimum of 1 meter in all directions outside the work area. There shall be no contact between persons over the gradient mat and those not over the mat, including the handing over of tools, instruments or other materials.
 1. Regardless of the approach selected, it is always advisable to handle the pipe (whenever possible) by the coated area of the pipe.
- O. All piping at tie-ins shall be bonded across the gap. All piping at cut-outs shall be bonded across before the cut-out is started. Prior to installing the cable bond at tie-ins and prior to removing the cable bond across cut-outs, each side shall be properly grounded as indicated in Item 6.1.
- P. Whenever a section of pipe must be lifted free of the earth on a web sling or equivalent for transport, the pipe steel so lifted should be electrically connected to a metallic portion of the tractor doing the lifting and transporting. This requirement may be waived if the lifting and/or transporting of the pipe can be accomplished with connections called for in Item 6 of these recommendations.
- Q. A grounding strap or chain shall be attached to each rubber tired vehicle with a secure electrical connection to provide a ground contact for the vehicle during both mobile and stationary operations. The grounding strap or chain shall be of sufficient length to provide three (3) feet of earth contact immediately after the vehicle comes to a stop within 200 feet from the centerline of high voltage overhead conductors.
- R. If steel chain is used for the grounding connection, it shall be of a minimum 1/4" size. If a strap is used for the grounding connection, it must be approved by the Owner before utilization.
- S. All bonding connections shall be made to driven ground rods as described above. Bonding connections shall not be made between the pipeline and the electric transmission line ground. Such a connection can result in high pipeline potentials during power line faults with current flow through the pipeline that could damage the steel as well as the coating.
- T. The pipeline shall not be bonded or grounded to foreign structures without permission of the Owner of the foreign structure. If permission is not granted, the foreign structure shall be electrically isolated from the pipeline under construction.

- U. Workers shall avoid at all times making simultaneous contact to a grounded and ungrounded structure.
- V. Other grounding materials and suppliers can be used subject to approval by Owner. Examples of other cable jumpers that could be used are:
 - 1. Cable jumpers using 50 lb. minimum pull magnet for connection to pipe, heavy equipment, fuel trucks and general use.
 - 2. Standard welding or battery jumper clamps with well-insulated handles, and teeth to bite into the metal.
- W. All grounding attachments and removals should be made by or under the direct supervision of the person in charge of electrical safety.

3.5 VOLTAGE MEASUREMENT

- A. The voltage to ground of any string of pipe exposed to contact by personnel shall be measured periodically by reading the voltage between the pipe and a clean steel pin driven in the ground.
- B. If the A-C voltage exceeds 15 volts above ground, supplementary grounds must be used to reduce this voltage to less than 15 volts. In the event that measured A-C voltage above ground exceeds 15 volts, the person in charge of electrical safety shall issue appropriate warnings and all work on the pipe string shall be suspended until potential is reduced to less than 15 volts.
- C. These grounds shall be maintained at all times. A record of a periodic measurement of induced voltage shall be obtained and the record of these readings maintained. The bonding entities shall be as widely separated as is possible. As the "still-above ground" portion of the construction advances, bonds should be kept close to the construction end. This may only be done by installation of a third or higher number bond near the "construction end" before removing a bond near the completed end.

3.6 VEHICLES

- A. Rubber tired equipment parked for any appreciable time on a power line right-of-way can obtain a significant static charge. Vehicles should be parked no closer than 200 feet from the centerline of high voltage overhead conductors.
- B. Refueling of any motor vehicles or construction equipment shall not be permitted within 100 yards of any electric overhead transmission facility unless right-of-way conditions are such that this distance is unobtainable. If the 100 yards minimum cannot be complied with, the maximum distance possible shall be obtained, then each fuel truck shall be grounded and shall be equipped with a cable assembly capable of completing an electrical bond between the truck and any piece of equipment to be fueled. This bond must be made each and every time the refueling takes place within 100 yards of any electric overhead transmission facility prior to any part of refueling operation. This bond shall not be removed until all refueling operations are completed. Care should be taken where the cable attachments are made so that good electrical continuity is established. No fueling operations shall be carried out within 50 feet of the power transmission line.
- C. At all times during construction, care must be exercised to assure that booms, cables and other equipment are no closer than 25 feet from overhead power lines. Height of conductors above

ground shall never be taken for granted but should be investigated in each case. Where operator of equipment is unable to personally assess that minimum distance is maintained, a second person shall be designated to guide the operator. Consideration must also be given to the possibilities of broken cables whip lashing close to power lines. It is recommended that each piece of equipment be positioned so that, should this occur, the cable would not come closer than 25 feet to a power line.

3.7 WEATHER LIMITATIONS

- A. All construction work shall be suspended in the area of overhead high voltage power lines during any potential lightning activity.

3.8 WARNING SIGNS

- A. The Contractor should post adequate signs warning of possible electrical hazards at each access to the right-of-way and any other measures required to prevent public access to temporary grounding installations.
- B. Warning signs shall be posted on all cranes and other hoisting equipment at locations that will always be in plain view of the operator. Said signs shall state: "Danger, do not operate any part of this equipment within 25 feet of the High-Voltage Lines." Similar warning signs shall be posted on various parts of the equipment.

END OF SECTION

DRAFT - NOT FOR CONSTRUCTION

SECTION 136000 MAINLINE VALVE PIPING FABRICATION

PART 1 - GENERAL

1.1 SCOPE OF WORK

- A. The Contractor shall furnish all labor, materials as shown on project drawings, scaffolding, tools, and equipment necessary to complete the piping fabrication requirements of the project. Company supplied materials are shown on project drawings. Included in the piping fabrication work is the following:
 - 1. All above and below ground piping inside Mainline Valve Station boundary limits as shown on project drawings.
- B. This specification defines the minimum requirements for shop and field fabrication, erection, inspection and testing of process and utility piping by the CONTRACTOR.
- C. The construction drawings and COMPANY specifications indicate the required piping class, materials and valve type. CONTRACTOR shall strictly adhere to the requirements of the COMPANY specifications for the materials, fabrication erection, inspection and testing procedures.
- D. This specification covers the fabrication of metallic pipe only.

1.2 REFERENCES

- A. Materials and installation shall be in accordance with the latest revisions of the following codes, standards and specifications, except where more stringent requirements have been specified herein:
 - 1. Part 192, Title 49, Code of Federal Regulation, including section 192.112 covering additional design requirements for steel pipe.
 - 2. API 1104 – Welding of Pipelines and Related Facilities
 - 3. ASME B31.8 – Gas Transmission and Distribution Piping Systems
 - 4. ASME Boiler & Pressure Vessel Code (BPVC) Section IX "Welding and Brazing Qualifications"
 - 5. ASTM material standards as shown in Mainline Valve station drawings.

1.3 CONTRACT DRAWINGS

- A. The Company shall provide the contractor with one set of general construction drawings for the mainline valve stations.

1.4 SHOP AND AS-BUILT DRAWINGS

- A. If not provided by COMPANY, the CONTRACTOR shall prepare piping isometrics and spool drawings for all piping. The isometric drawings shall show all spool numbers, welded attachments, location and type of welds (shop or field), type of pressure test and test pressure, other notes on construction, post weld heat treatment requirements, NDE requirements and a complete bill of materials. Where the COMPANY has supplied isometrics the CONTRACTOR shall review, annotate and prepare all additional isometrics in accordance with the above to fully define the piping spool

fabrication and piping installation scope of work. The COMPANY will carry out spot checks on the isometrics to ensure that the correct materials are called out.

- B. The CONTRACTOR shall ensure that all positions and locations of piping components, piping runs and terminal points are maintained.
- C. The CONTRACTOR shall verify that all spools, whether built from isometrics or shop drawings, are of a length which will enable the spool to be trucked if necessary and enable spools to be easily installed. Spools requiring field weld connections shall have ample length at weld connection ends to allow for trim for proper fit and weld bevel preparation.
- D. CONTRACTOR shall maintain an up to date, complete and accurate record of all minor changes made to design drawings during the fabrication and erection of the piping. Upon completion of the project, the CONTRACTOR shall mark all changes on one set of shop drawings and "As Built" construction drawings. COMPANY will not consider that Work is completed until the as-built drawings are received. If CONTRACTOR was responsible for piping design, the as-built marks shall be incorporated into CONTRACTOR's drawings for issue with final documentation.

PART 2 - MATERIALS

2.1 GENERAL

- A. Upon delivery of any COMPANY supplied material, the CONTRACTOR shall assume responsibility of the materials and the certification covering the materials. The CONTRACTOR shall be responsible for the supply of all other materials including temporary material and consumables to enable the work to be completed.
- B. The CONTRACTOR shall be responsible for ensuring that all materials fully comply with applicable COMPANY specifications. Materials shall not be considered for use unless the CONTRACTOR is in possession of the necessary documentation, e.g., Material Test Reports and other specialized test data as required by the references shown in section 1.2 of this specification.
- C. No substitution of materials shall be permitted unless prior written approval is obtained from the COMPANY.
- D. Should the COMPANY discover that "out of specification" material has been utilized, or material has been substituted without the written approval of the COMPANY, the CONTRACTOR shall replace all non-specification materials and take remedial actions as required to ensure compliance with specifications. The cost of this work shall be borne by the CONTRACTOR.
- E. Material Test Reports (MTR's) shall be provided by CONTRACTOR for all pipe and fittings. Complete traceability of piping material, is required for all piping. Traceability shall be recorded by noting heat number of piping components on piping isometric on spool drawing markups. Heat numbers shall also be marked on the piping components, and be maintained until shop fabrication is completed and numbers are recorded on isometrics.
- F. All piping materials must comply with Part 192, Title 49, Code of Federal Regulation, including section 192.112 covering additional design requirements for steel pipe.

2.2 GENERAL FABRICATION

- A. All materials which require documentation in use during fabrication or installation that cannot be identified with documentation shall be immediately removed from the area and replaced at the CONTRACTOR's expense.
- B. The CONTRACTOR shall maintain "clean" fabrication areas for the fabrication of stainless steel and nickel alloy piping to minimize the possibility of contamination.
- C. The CONTRACTOR shall pay specific attention to the segregation of tools and the protection of materials.
- D. The CONTRACTOR shall utilize shop tools and equipment compatible with materials in fabrication, including but not limited to grinding discs and power brushes designed for use with stainless steel and/or other high alloy materials.
- E. All spools shall have their piece number clearly designated on each spool piece, corresponding to the appropriate drawing.

2.3 PIPING FABRICATION & ASSEMBLY

- A. All pipe, fittings, flanges, in-line, on-line and piping specialty items shall be provided and installed in accordance with the COMPANY construction drawings.
- B. Flange bolt holes shall straddle horizontal and vertical center lines unless noted otherwise on the construction drawings.
- C. All flanged connections shall be made up by tightening the flange bolts in an accepted pattern to an even torque. CONTRACTOR shall torque all flange connections with a calibrated torque wrench per a COMPANY approved procedure. CONTRACTOR shall hang a torque tag on the flange connection after torquing.
- D. Dimensional tolerances for fabrication and installation of piping shall be plus or minus 1/8" at equipment tie-in points unless otherwise noted on the drawings.
- E. Flange faces shall be aligned within $\pm 1/2^\circ$ from square with pipe, regardless of orientation.
- F. The CONTRACTOR shall be responsible for locating required assembly/field welds. Inclusion of field welds on COMPANY provided piping drawings shall not relieve the CONTRACTOR of the responsibility of providing additional assembly/field welds which may be required.
- G. CONTRACTOR shall also be responsible for allowing additional cut length at field/assembly welds adequate to accommodate normal fabrication variations in both CONTRACTOR's fabrication and fabrication of COMPANY supplied equipment. Unless otherwise noted, minimum 6" of extra cut length shall be provided at field welds indicated on COMPANY provided piping isometrics.
- H. Piping shall be installed plumb, level and square unless designated otherwise on the construction drawings.
- I. Screwed threads shall be clean cut with no burrs or stripping. Dies shall be new, sharp, and properly designed for the piping material. Immediately before erecting the piping, all pipe threads and fittings shall be thoroughly cleaned of cuttings, dirt, oil or other foreign matter. Teflon tape shall be used for all screwed connections. Care shall be taken to ensure that the tape is wound in the correct direction and that the tape does not enter the inside of the pipe.

- J. Piping shall be erected and supported in a manner that will not put undue strain on equipment. All equipment, prefabricated piping, and appurtenances shall be fitted and assembled strain-free. The CONTRACTOR shall be prepared to demonstrate, by disassembly of the spool, the strain-free state of all fabricated piping.
- K. For screwed or socketweld pipe installations, CONTRACTOR shall install sufficient unions to allow for convenient removal of any spool or component without disassembly or removal of any piece of equipment or major inline instrumentation.
- L. Valve handles and wrenches shall be modified by CONTRACTOR where necessary for proper valve operation, and when the valve cannot be otherwise rotated to clear the obstruction.
- M. Thread-O-Lets shall not be installed on elbows. Elbow-Lets shall be used for branch connections at elbows.

2.4 PIPE SUPPORT FABRICATION

- A. CONTRACTOR shall procure, fabricate, and install all pipe supports as noted on project drawings. CONTRACTOR shall also design pipe supports, if this design is not provided by COMPANY, or for supports required which are not included in COMPANY designed items.
- B. Welding of attachments for the purposes of supports shall be carried out as part of the piping fabrication in accordance with the applicable codes and standards. All other parts shall be fabricated in accordance with ANSI/AWS D1.1 and the guidelines in AISC, "Manual of Steel Construction".
- C. If not provided by COMPANY, the CONTRACTOR shall purchase and install all support specialty items in accordance with construction drawings, COMPANY specifications, and good engineering practice.
- D. All relief, blowdown and safety head discharge piping shall be securely braced for relieving conditions.

2.5 WELDING

- A. General
 - 1. All piping welding shall be carried out to an approved weld procedure specification by a welder qualified in accordance with the ASME Code for the procedure and in the position the welding shall be carried out in accordance with this specification.
- B. Cutting and Preparation
 - 1. The ends of all pipe to be butt welded shall be prepared in accordance with ASME B31.8 and the governing welding procedure specification.
 - 2. Bevels shall be made by machine tool or machine thermal cutting. Manual thermal cutting shall not be permitted unless specifically approved by COMPANY on a one by one basis. The bevelled ends shall be smooth and uniform, and dimensions shall be in accordance with the qualified welding procedure/drawing requirements. Burrs, small scuff marks, indentations or small defects within the joint preparation area shall be blended out by grinding, otherwise the joint should be re-prepared.
 - 3. The pipe ends and faces forming part of a welded joint shall be cleaned down to sound metal immediately prior to making the joint. All paint, grease, scale, rust, and other extraneous

matter shall be removed. The cleaning shall extend for at least 1" from the edge of the bevel on both the internal and external faces of the components to be welded.

C. Weld Procedure Specifications

1. All welding shall be carried out to approved welding procedure specifications. Each welding procedure specification and supporting procedure qualification records shall be submitted to COMPANY for approval prior to starting any fabrication.
2. Welding procedures shall be in accordance with ASME Boiler & Pressure Vessel Code (BPVC) Section IX "Welding and Brazing Qualifications" or API 1104.
3. The CONTRACTOR shall bear all costs for preparation and qualification of all weld procedures required for the work.
4. CONTRACTOR shall employ a welding procedure that provides a smooth, regular fully penetrated inner surface for meter tubes.

D. Welder Qualifications

1. Welders to be used on the project shall be qualified for each welding process they will use in the position they will use it in accordance with ASME B31.8 and CFR Title 49, Part 192 Code requirements.
2. The CONTRACTOR shall bear all costs for qualifying all welders. For each welder qualification test, laboratory tests shall be carried out as required by the applicable code.

E. Identification of Welders and Welds

1. Each welder shall be assigned a unique identifying number or symbol that identifies each individual welder's work.
2. All welds shall be stenciled (stamped) with the welder's number or symbol within 1½" of the weld using low stress concentration dies. Pipe with wall thickness too thin to apply stencils without deforming or alloy pipe is to be marked with approved markers or engraved. Stencils are to be recorded on the weld map or spool drawings and included in manufacturing data. Welds not stenciled shall be removed and replaced at the CONTRACTOR's expense.

F. Pipe Welding Requirements

1. Preheat shall be in accordance with ASME B31.8 requirements.
2. When the ambient temperature is less than 40 °F, carbon steel shall be pre-heated to a minimum of 150 °F prior to welding. Preheat temperatures for low and high alloy steels shall be stated in the welding procedure specifications. Preheat and interpass heating requirements and methods shall be addressed in the appropriate Welding Procedure Specifications. The temperature shall be monitored with the use of temperature indicating crayons placed a minimum of 3" from the edge of the heat affected zone.
3. Any pinholes, cold lap, slag, flux, or other impurities that appear on any surface during or after welding shall be removed by grinding or chipping before depositing the next successive bead.

4. All passes of all welds shall have all oxides and slag removed to permit clear visual inspection and to prevent unacceptable slag indications in radiography film.

G. Weld Repairs

1. All weld repairs shall be carried out to an approved weld repair procedure. The approved procedure shall include for the mechanical removal of defective material, and blending of excavation.
2. Weld repairs shall be inspected and tested in accordance with Section 5. NDE of repairs to be completed using the same method that detected the defect.
3. Additional examination of welds completed by the welding operator is to be completed as required by the governing ASME / API welding code.

PART 3 - EXECUTION

3.1 INSPECTION

A. General

1. COMPANY reserves the right to inspect all materials, fabrication, workmanship, welding of materials and fabricated components. COMPANY or its representative shall have free entry at all times to any part of the CONTRACTOR's or subcontractor's facility where manufacture of COMPANY components occurs.
2. The approval of any work by COMPANY and their release of piping for shipment shall in no way relieve CONTRACTOR of any responsibility for carrying out the provisions of this specification, or for compliance with applicable codes.
3. The COMPANY shall be responsible for Non-Destructive Testing (NDT) as stated in this specification.
4. The inspection and NDT requirements of this section are those required by the COMPANY and are not intended to restrict in any way whatsoever the good working practice and internal QA / QC of the CONTRACTOR.
5. The COMPANY reserves the right to carry out NDT in addition to that required by the scope of work. Where the additional NDT shows unacceptable defects then all remedial works for rectification shall be considered wholly within the CONTRACTOR's scope of work.
6. COMPANY NDT operators will be trained and qualified in accordance with guidelines SNT-TC-1A of the American Society of Non-Destructive Testing.

B. Non Destructive Testing (NDT)

1. The COMPANY shall be responsible for Non-Destructive Testing (NDT) as stated in Table 1 of this specification, and for all other NDT requirements specified herein. The definition of 10% inspection shall be 100% of 10% of the welds designated by the COMPANY for the designated pipe size and specification.
2. NDT as shown in table 1 shall apply to both CONTRACTOR shop and field welding activities.

3. If NDT shows unacceptable defects, then all remedial works for rectification shall be considered wholly within the CONTRACTOR's scope of work. Further NDT due to unacceptable defects, shall be charged to the CONTRACTOR.

Pipe Class	Minimum Inspection Required	
	Threaded / Socketweld	Buttwelded
150# Class Piping	10% Magnetic Particle	10% Radiography
600# Class Piping	10% Magnetic Particle	100% Radiography

C. Radiographic Inspection

1. Radiographic inspection methods and acceptance criteria will be in accordance with API 1104. All radiographic inspection shall be at COMPANY's expense and performed by a third party.
2. Each radiographic film will be properly identified with a corresponding weld map marked drawing, or NDT map.

D. Ultrasonic Inspection

1. Where a weld is subject to 100% radiography but will not yield an interpretable radiograph then the weld shall be subject to ultrasonic inspection in lieu of radiography.
2. Ultrasonic inspection methods and acceptance criteria shall be in accordance with API 1104.

E. Magnetic Particle Inspection

1. Magnetic particle inspection shall be used only on carbon steel.
2. Where magnetic particle inspection is specified, only the "wet" method will be used. MT procedures shall detail types of particle suspension fluids, contrast paints, and types of devices used for the inspection.
3. Welds to be examined by magnetic particle inspection shall be sufficiently smooth to avoid false defect indications.
4. Magnetic Particle inspection methods and acceptance criteria shall be in accordance with API 1104.

3.2 TESTING

A. General

1. A pressure test shall be performed on facilities piping with piping spools assembled and joined in the final location. A minimum number of tie-in welds will be permitted with company approval
2. The CONTRACTOR shall develop procedures covering system preparation, flushing, pressure testing, drying and preservation and submit for approval. The procedures shall define the methodology, materials, safety equipment, and instrumentation for documentation, testing media, duration and disposal. The procedures shall provide sufficient detail for the COMPANY to evaluate the work to be performed. The CONTRACTOR shall be responsible for ensuring the safety of all personnel engaged in and witnessing of the tests. The safety provisions shall be clearly stated in the hydrostatic and pneumatic testing procedures.

Pneumatic testing will only be performed with prior written approval from COMPANY. A separate procedure shall be submitted outlining all steps of the testing including a safety plan to protect personnel.

3. The CONTRACTOR shall provide all equipment, materials and consumables required for the system preparation, flushing pressure testing, drying, preservation and reinstatement. All test equipment and temporary materials shall be compatible with the pressure rating and material of the system under test. Gaskets intended for final assembly shall not be used for test purposes. The welding of temporary fittings for test purposes shall be carried out to the same standards as the piping under test. No NDT (except for welding attachments to permanent job piping) will be required by the COMPANY on these welds unless otherwise stated by COMPANY or required by COMPANY Inspector.
4. Recorders utilized for testing shall be capable of recording pressure & temperature. Recorders and pressure gauges shall be rated at not more than double the test pressure (300 psi gauge for a 150 psi test, etc.)
5. All pressure tests shall be witnessed and accepted by the COMPANY, its representatives or a third party inspector authorized by the COMPANY.
6. Hydrotest water shall be clean, fresh, non-corrosive water, free of undissolved solids and available at a minimum of 45 °F.

B. System Preparation

1. Prior to system preparation all piping shall have been cleaned to remove mill scale, weld spatter, dirt and other foreign matter. All welding, NDT and stress relieving shall be complete and accepted by COMPANY as complete. All welds and flanges shall be clean and exposed for external inspection.
 - a. All in-line equipment or devices which may be damaged or hamper the test shall be
 - b. Removed from the system. All sensitive in-line and on-line instrumentation items shall be removed or isolated and this shall include, but not limited to the following:
 - 1) Pressure vessels or any mechanical equipment
 - 2) Check valves or check valve flappers
 - 3) Restriction orifices / orifice plates
 - 4) Positive displacement meters
 - 5) Turbine type meters
 - 6) Self regulated controllers
 - 7) Relief valves
 - 8) Rupture Discs
 - 9) Level controls and switches
 - 10) Filter elements
 - 11) Diffusers
 - 12) Transmitters
2. Equipment removed for pressure test shall have documentation of manufacturer's pressure ratings and/or factory test records.

C. Pressure Testing

1. All piping shall be subject to a hydrostatic test or pneumatic test in accordance with CFR Title 49, Part 192, Subpart J. Piping shall be tested to 1.5 times MAOP. Test media shall be approved by COMPANY and shall not be harmful to the piping materials or the environment.

D. Hydrostatic Test

1. Valves shall generally be in the open, or half open, position for test. A closed valve may be used as isolation of a test only with specific approval of COMPANY, and after confirmation that the valve seats are rated for the test pressure. Provisions to vent air from the test arrangement shall be made prior to filling with test media.
2. The area where testing is to be performed is to be barricaded to prevent access by unauthorized personnel during the testing.
3. The piping shall be slowly filled with water until all air is evacuated. Temperature of the pipe shall be allowed to equalize with that of the test media prior to applying pressure. The vents shall be closed and the piping shall be slowly pressurized to 50% of the test pressure and visually inspected for leaks. When it is confirmed no leaks exist, pressure shall be increased in increments of 25% of test pressure until the test pressure is reached. When leaks are identified, the pressure shall be reduced to the level not greater than the previous increment 0 psi before flange bolts shall be torqued to stop the leak. Flange bolts shall not be torqued over allowable stresses. Where the leak cannot be stopped, pressure shall be relieved from the arrangement and inspection to determine the cause of the leak shall be carried out; this may require disassembling connections.
4. The piping shall be carefully inspected for leaks or distortions during the test. Inspection may require remote observation depending on test pressure and/or test media in order to safeguard personnel. For acceptance, no leaks or distortions in the piping are permitted.

E. Pneumatic Testing

1. All applicable guidelines for hydrostatic testing shall be followed. In addition, the space between the faces of all flanges connections shall be wrapped with duct tape shrink wrap, or other media that will seal the area and a small hole shall be punched through the tape, plastic, or other media at the top of the flange.
2. The piping shall be pressurized to 25 PSI and gross air leaks shall be remedied. The piping shall be slowly pressurized to 50% of the test pressure, then increased in increments of 10% until the test pressure is reached. Leak detector solution shall be applied to all threaded connections, welds, and at the holes in the sealing material applied at flange connections. When leaks are identified, the pressure shall be reduced to 0 PSI before flange bolts are retorqued or threaded connections tightened to stop the leak. Where the leak cannot be stopped. Pressure shall be relieved from the arrangement and inspection carried out; this may require disassembling connections.

F. Reading, Measurements & Test Duration

1. Pressure test duration shall be 8 hours, maintained at a pressure equal to or above the test pressure. Both chart recorders and hydraulic deadweight gauges shall be used for test measurement. Deadweight gauge readings shall be taken every hour. Chart recorders and pressure gauges shall have a valid calibration certificate within 6 months.

G. Records

1. The CONTRACTOR shall provide documentation to record each pressure test. CONTRACTOR shall provide test records in accordance with CFR Title 49, Part 192, Subpart J.
2. If the piping fails the pressure test then no test chart will be signed off. The CONTRACTOR shall be responsible for all remedial work, repairs and retesting of piping that fails during testing. All rework shall be carried out in accordance with the relevant specifications and procedures.

H. Reinstatement

1. After a successful test, the piping shall be emptied of the test medium. Where applicable, pressure tested piping shall be reinstated in accordance with project drawings. Where a hydrotest has been completed, pipe shall be dried post-hydrotest using a suitable method. The piping shall be subject to preservation to ensure no deterioration prior to system commissioning.

END OF SECTION

DRAFT - NOT FOR CONSTRUCTION

SECTION 260501 ELECTRICAL – GENERAL INSTALLATION REQUIREMENTS

PART 1 - GENERAL

1.1 SCOPE OF WORK

- A. This specification covers the requirements for the supply of equipment, material, labor, tools, services and supervision as required for the installation, testing and placing into satisfactory operation of the electrical systems detailed in this specification and the attached drawings.
- B. Any equipment and materials, other than those identified as being pre-purchased by the Company, necessary for the installation and wiring of the equipment within the scope of this contract shall be supplied by the Contractor.
- C. The drawings presented outline the scope of the work required of the Contractor and are to be the basis of the Contractor's bid. The Contractor may offer for consideration alternates that are cost effective so long as these are clearly defined and approved by the Company.
- D. The Contractor shall be responsible for sizing of all junction boxes and splitter boxes, verification of conduit sizes, conduit fill and loadings, cable ampacities and short circuit ratings for all Contractor-supplied equipment and materials.

1.2 REFERENCES

- A. Materials and installation shall be in accordance with the latest revisions of the following codes, standards and specifications, except where more stringent requirements have been specified herein:
 - 1. Local Building Codes
 - 2. Building Code of Vermont
 - 3. Fire Code of Vermont
 - 4. National Fire Protection Association (NFPA)
 - 5. National Electrical Code(NEC)
 - 6. Underwriters Laboratories, Inc. (UL)
 - 7. National Electrical Manufacturers Association (NEMA)
 - 8. Institute of Electrical and Electronic Engineers (IEEE)
 - 9. American Society of Testing Materials (ASTM)
 - 10. Insulated Cable Engineers Association (ICEA)
 - 11. Association of Edison Illuminating Companies (AEIC)
 - 12. American National Standard Institute (ANSI)
- B. In general, all electrical equipment furnished shall be listed and labeled by Underwriters Laboratories, Inc. (UL) or another acceptable organization to the "Authority having Jurisdiction" and the Company. This requirement will be waived only when the specified equipment is not available from any manufacturer with such a label or listing.

1.3 WORK TO BE DONE

- A. The work to be done by the Contractor under this specification consists of the installation, supply of materials, off-loading of equipment, and inspection and testing, as specified.
- B. Electrical equipment installed by the Contractor shall include equipment in Vermont Gas Systems – Addison Natural Gas Project Mainline Valve Stations.

- C. In general, the equipment to be supplied and installed by the Contractor shall consist of, but not be limited to the following:
1. Supply and installation of all low voltage, control, signal and communication conduits and cabling.
 2. Installation of any Company pre-purchased equipment.
 3. Installation and termination of all RTU / DAC Panels in electronics buildings as shown on Drawings.
 4. Supply, installation and termination of all junction boxes as shown on Drawings.
 5. All conduit and raceway systems.
 6. Lighting transformers and distribution panels
 7. Building lighting system
 8. Building receptacles, switches and heater
 9. Building and equipment grounding system
 10. Electrical check-out of all equipment installed and provide assistance to Company with commissioning and operational testing of all equipment and facility systems.

1.4 QUALITY ASSURANCE

- A. Uniformity: Unless otherwise specified, equipment or material of same type of classification, used for the same purpose shall be products of same manufacturer. All material shall be new and of the current design of manufacturer providing equipment or material. All materials shall be as stated on project drawings. Any substitutions by contractor shall be approved by Company.
- B. Design: Equipment and accessories not specifically described or identified by manufacturer's catalog numbers shall be designed in conformity with NEMA, IEEE, or other applicable technical standards and shall have neat and finished appearance.
- C. Installation: Erect equipment in neat and workmanlike manner; align, level and adjust for satisfactory operation; install so that parts are easily accessible for inspection, operation, maintenance and repair. Minor deviations from indicated arrangements may be made, but only after obtaining approval from Company.

1.5 CONTRACT DRAWINGS

- A. Location Approximate
1. The locations of equipment, fixtures, outlets and similar devices shown on the Contract Drawings are approximate only.
 2. The Contractor shall determine the exact locations of the equipment, outlets, box-outs, sleeves and of similar items required for the coordination of electrical work with the structural, architectural, mechanical and other work as necessary.

B. Drawings Diagrammatic

1. Circuit diagrams shown are diagrammatic and functional only and are not intended to show exact circuit layouts, number of fittings, or other installation details.
2. The Contractor shall furnish all labor and materials necessary to install and place in satisfactory operation all power, lighting and other electrical systems.

1.6 CONTINUITY OF SERVICES

- A. When buildings are in use during construction operations, keep all electrical systems in operation within all rooms of building at all times.
- B. Schedules for various phases of Work shall be coordinated with all other trades and with Company.
- C. Provide necessary and temporary connections and relocations as required to maintain systems in operation.
- D. When connecting new facilities, do not shut off any Mechanical/Electrical facilities or services without prior written approval of the Company.

1.7 PROTECTED WORK

A. Hazardous Locations

1. In the areas designated as Hazardous and where explosion-proof work is shown or specified, all work and electrical equipment shall meet the requirements of the NEC for Class I Division 1 and 2 Group D locations unless otherwise noted.

B. Wet Locations

1. Where installed outdoors or in areas designated as Wet Locations, all work and electrical equipment shall meet the requirements of the NEC for Wet Locations.

1.8 INSPECTIONS AND APPROVAL

- A. The Contractor shall have all electrical work inspected by the following agencies and this work shall pass such inspection:

1. Vermont Division of Fire Safety

- B. The Contractor shall furnish to the Company a certificate of compliance stating that the completed installation complies with the requirements of the National Electrical Code. This certificate shall be completed by the agency listed above.

- C. Any changes required by the authorities resulting from deficiencies in the Contactor's workmanship shall be implemented by the Contractor without cost to the Company.

1.9 SUBMITTALS

- A. Contractor shall supply a submittal for all Contractor-supplied materials and equipment as indicated in the Electrical Technical Specifications.

PART 2 - PRODUCTS

2.1 EQUIPMENT AND MATERIALS SUPPLIED BY CONTRACTOR

- A. The Contractor shall supply all equipment and materials needed for the electrical installation as shown on drawings.

2.2 MATERIAL CONTROL

- A. The Contractor shall establish a very strict and comprehensive material control scheme, to warn of any potential material shortages.

2.3 DELIVERY, HANDLING AND STORAGE OF MATERIAL

- A. Materials and equipment shall be delivered to the site of the work in their original containers, and containers shall not be opened until inspected by the Company.
- B. Electrical equipment shall at all times during construction be adequately protected against mechanical injury or damage by weather.
- C. If any materials or apparatus have been damaged, the apparatus or materials shall be restored to a new condition, subject to the inspection and approval of the Company, or replaced with new materials or apparatus.
- D. Equipment shall be stored in accordance with manufacturer's recommendations. Temporary heaters shall be provided as required to prevent buildup of condensation in the equipment.

PART 3 - EXECUTION

3.1 GENERAL EQUIPMENT INSTALLATION

- A. The installation of equipment shall be defined as the receiving, off-loading, storing where necessary, moving into its designated location, uncrating, assembly, setting up, connection to other equipment and preparing for operation, all in accordance with the Specification and with the Vendor's instructions and Installation Manuals.
- B. The installation of cables shall be defined as the receiving, off-loading, storing where necessary, pulling out of cables, placing in conduit as required, entering the cables into panels and terminating.
- C. The Contractor shall ensure that the cables and equipment are kept clean and are protected against damage, dust and moisture.
- D. Cable ends shall be kept sealed to prevent the ingress of moisture.
- E. Unless otherwise specified, the Contractor shall supply, fabricate, construct and erect all support brackets on mountings for all equipment supplied by the Contractor.

3.2 MAIN EQUIPMENT INSTALLATION

- A. Wall mounted equipment shall be fastened to steel brackets to provide an installation that is true, plumb, secure and safe.

- B. Vendor drawings and instructions for the installation of Company pre-purchased equipment will be made available to the Contractor. It shall be the responsibility of the Contractor to follow these documents during the installation, wiring, testing and energization of the equipment.
- C. Installation of safety signs as required by code regulations or stipulated by the Engineer shall be the responsibility of the Contractor.

3.3 IDENTIFICATION

A. Equipment and Devices

1. All electrical equipment shall be clearly identified with its equipment number, function and voltage.
2. Each power and distribution panelboard, circuit breaker, junction box, etc. shall be identified with white lamacoid nameplate with black engraving, mechanically secured to the front with the screws or rivets to indicate function, voltage and equipment number as specified on the drawings. Enclosure ratings shall not be compromised in the attachment of labels. Labeling in accordance with NFPA70E must be applied where required.
3. Each power and distribution panelboard shall be equipped with a directory card, neatly typed with the final circuit designation and placed in the card holder under a transparent cover on the inside of the door of each panelboard.
4. The Contractor shall install "High Voltage" warning signs and "Danger" signs as called for by the safety regulations as required by code.

B. Cables and Conductors

1. All cables in panels, pullboxes, junction boxes and switchboards shall be tagged at both ends with the cable number assigned in the cable schedule/drawings. Tags shall be non-aging, labels which encircle the cable.
2. Both ends of all wires of each cable shall be clearly and permanently identified with wire markers, at the terminal to which they connect, with the proper wire number as shown on the drawings or wire termination sheets. Non-aging approved markers which encircle the wire shall be used.
3. All terminals for external connection shall be plainly and permanently marked, on approved marking strips as shown on the drawings or wire termination sheets.

3.4 AREA CLASSIFICATION

A. If the scope of work includes installations in hazardous area, the Contractor will be issued an area classification drawing indicating the Class, Division and Group designations in accordance with the NFPA classification for the different work areas.

B. The Contractor shall ensure that all equipment, materials and installation methods are suitable for the area classifications and shall report any discrepancies to the Company for correction.

3.5 SEALS AND FIRE STOPS

A. In hazardous locations, sealing fittings (seal offs) shall be installed in all conduit runs on the outside of buildings where the conduits enter the building. In addition, approved drain fittings

shall be installed at the bottom of these conduit runs and in all outdoor junction boxes to drain off any accumulated moisture.

- B. Sealing fittings shall be installed for explosion proof work in accordance with in accordance with the provisions of Article 501 of the National Electric Code for Class 1, Group D, Division 1 and 2 locations. Compound filled seal off fittings as specified shall be installed as required.
- C. Seal offs shall be located in conduits not more than 16 inches from points of penetrations through floors or walls and where emerging from earth. Seal offs shall be sized in accordance with the latest requirements of the NEC.
- D. Fire stops shall be provided for all cable penetration in floors and walls to prevent spread of fire, dust, water and gases from one area to another. The material used for sealing of all cable penetrations shall be non-combustible and shall have low heat transfer. The sealed opening shall have a fire rating equal to that of the surrounding wall or floor.
- E. Use 3M fire Barrier Caulk CP-25 or Putty 303 or equal.

3.6 ELECTRICAL EQUIPMENT PAINTING AND CLEANUP

- A. All distribution panels, steel work and similar indoor and outdoor equipment furnished with enameled epoxy or lacquered finish or which are galvanized and which are scratched or defaced during construction shall be refinished and restored to the original finish by the Contractor.
- B. All exposed steel surfaces on electrical equipment panels, unless already supplied galvanized or epoxy painted, shall be cleaned, prime coated and finish coated with an epoxy enamel.
- C. The Contractor shall make a thorough inspection of all electrical equipment, remove any left over packing braces, shipping supports and thoroughly clean all equipment by hand operated vacuum machine.
- D. The Contractor shall clean up all lighting fixtures. Damaged parts shall be removed and replaced. All burned out lamps shall be replaced.

END OF SECTION 260501

SECTION 260521 WIRE & CABLE (600V OR LESS)

PART 1 - GENERAL

1.1 SCOPE OF WORK

- A. Provide a cable system complete with all materials, including cables, wire, connectors, lugs and fittings as indicated in the specification or as indicated on the drawings. All cables and wiring shall be complete with identification tags per this Specification Section.

1.2 STANDARDS

- A. Furnish cable, wire and wiring accessories listed by Underwriters' Laboratories (UL) as meeting National Electrical Code requirements and bearing the UL label where available for the equipment specified. In addition, the cable type shall have been submitted to standard tests established or approved by ASTM, ANSI, ICEA and NEMA.

1.3 SUBMITTALS

- A. Submit Vendor data for all types and sizes of cables and wires being supplied by the Contractor. Identify material, construction data, color coding, insulation and jacket thickness and typical test data.
- B. Submit Vendor data for the cable and wire identification tags to be supplied.

PART 2 - PRODUCTS

2.1 LOW VOLTAGE POWER CABLES (600 VOLTS OR LESS)

- A. Multi-conductor low voltage power cables when installed in cable tray shall be type "MC", Class B stranded copper conductor, 600 Volt rated, XHHW or THHN conductor insulation, 90°C conductor temperature, with bare copper ground wire, binder tape and overall black, flame retardant PVC jacket.
- B. Low voltage power cables installed in conduit shall as listed below. A suitable insulated ground conductor shall be installed adjacent to the phase conductors and must not be less than 45% of the phase conductor cross sectional area.
 - 1. THHN (90°C damp or dry) insulation shall be used in damp or dry locations for all sizes.
 - 2. XHHW (75°C wet or 90°C dry) insulation shall be used in wet locations for all sizes.
- C. Conductors shall be annealed copper, 98% conductivity.
- D. Minimum size conductor for general wiring shall be #12 AWG.

2.2 CONTROL CABLING

- A. Multi-conductor control cable shall be 600 Volt rated, type "MC" when installed in cable tray, Class B stranded copper conductor, PVC/nylon insulated, UL type THHN 90°C, with an overall flame retardant PVC jacket rated at 90°C and overall aluminum mylar shield when indicated on the drawings. Conductors shall be color coded per ICEA S-66-524 Method 1, Table K-2 and shall be number printed.

- B. Single conductor control wiring for insulation in conduit shall be of insulation type THHN for damp and dry locations and XHHW when installed in wet locations.
- C. Minimum size conductor for control wiring shall be #14 AWG.

2.3 INSTRUMENTATION AND SIGNAL CABLE

- A. Instrumentation and signal cables, shall be 300 Volt rated type "MC" when installed in cable tray, Class B stranded copper conductor, flame retardant, 105°C PVC conductor insulation, color coded, twisted pairs, triplets or quads, with aluminum mylar shield, stranded tinned copper drain wire and overall PVC jacket rated at 90°C. Belden Type or approved equal.
- B. Minimum size of instrumentation and signal wiring shall be #18 AWG.

2.4 THERMOCOUPLE CABLE

- A. Thermocouple cable shall be 300 Volt rated type "MC" when installed in cable tray, Class B stranded copper conductor, flame retardant, 105°C PVC conductor insulation, color coded, twisted pairs, triplets or quads, with aluminum mylar shield, stranded tinned copper drain wire and overall PVC jacket rated at 90°C. Belden Type or approved equal.
- B. Minimum size of instrumentation and signal wiring shall be #18 AWG.

2.5 DIRECT BURIAL CABLES

- A. Not used.

2.6 WIRE CONNECTION DEVICES FOR SPLICING

- A. No splicing shall be permitted.

2.7 TERMINATING LUGS

- A. Lugs for terminating power conductors up to and including #8 AWG shall be color coded, solderless compression or bolted type, unless otherwise indicated.
- B. Lugs for terminating power conductors #6 AWG and larger shall be color coded, solderless compression type, one-hole for #6 AWG through #4 AWG inclusive, and two-hole for larger sizes.
- C. Lugs for terminating control and switchboard wiring shall be color coded, solderless compression type with tinned copper ring tongue. Spade type lugs are not permitted in any control, protection or alarm circuits.

2.8 WIRE AND CABLE LABELS

- A. Labels shall be non-aging, labels which encircle the cable or wire as applicable.
- B. Refer to section 26 05 01 for cable and wire identification requirements.

PART 3 - EXECUTION

3.1 INSTALLATION

- A. No cables or wires shall be installed in conduits or ducts until the entire installation is completed and cleaned inside and out. When installing cables, the Contractor shall exercise due care to prevent damage to cables and raceways; avoid undue tension, bending and kinks.
- B. Only approved cable lubricants, expressly manufactured for this purpose shall be used.
- C. The Contractor shall install conductors in such a manner that the bending radius of any wire or cable is not less than the minimum recommended by ICEA and/or the manufacturer. Do not exceed the manufacturer's recommended values for maximum pulling tension applied to any cable or wire.
- D. All power conductors and cables shall be run full length without splices and shall be continuous from origin to termination. Where splices are necessary and approved, they shall be made in approved splice boxes with suitable connectors. All splices shall be insulated with heat-shrinkable heavy-wall flame-retardant cable sleeves.
- E. Thoroughly clean wire ends before connectors or lugs are applied.
- F. Jumpers shall be installed inside the various panels as indicated in the cable termination sheets/drawings.
- G. All power conductors in multi-color cables shall be color coded consistently, distinctly and continuously throughout the work. Color coding tape shall be utilized and applied at all terminations, junctions, pull boxes and conduit fittings.
- H. Single conductor cables having black insulation for power feeders and sub-feeders shall be identified by colored tape as to phase connections.
- I. Conductor terminators for all power cables sizes shall result in a connection both mechanically and electrically secure and approved for the application regarding dissimilar metals.
- J. Control and instrument cables shall be terminated at panels, junction boxes and individual device enclosures using approved fittings.
- K. The Contractor shall install phase and neutral conductors of each branch or feeder circuit in a single conduit except where paralleling circuits are indicated on the circuit schedule. Install paralleling circuits of identical makeup and length as the paralleled circuit, and terminate conductors at the same location, mechanically and electrically, at both ends, to ensure equal division of the total current between conductors.
- L. The Contractor shall connect all AC power wiring to equipment.

END OF SECTION

SECTION 260527 GROUNDING & BONDING SYSTEMS

PART 1 - GENERAL

1.1 SCOPE OF WORK

- A. Provide grounding and bonding system as specified or indicated on the drawings.

1.2 STANDARDS

- A. Ground the electrical system neutrals and bond the non-current carrying parts of electrical equipment as indicated in the specification or drawings and as a minimum the grounding and bonding must meet the requirements of the National Electrical Code.

1.3 SUBMITTALS

- A. Submit product data for conductors, connectors and devices supplied for use with the grounding system.

PART 2 - PRODUCTS

2.1 GROUNDING AND BONDING CONDUCTORS, CONNECTORS AND DEVICES

- A. Provide the grounding and bonding conductors, connectors and devices of the type specified on the drawings.

PART 3 - EXECUTION

3.1 EQUIPMENT AND BUILDING BONDING

- A. Static grounding (bonding) of equipment shall be by means of bonding the equipment to the embedded ground grid as indicated on the drawings.
- B. Bolted connections shall be used on all equipment and building bonding. A washer shall be used between the bolt head and terminal lug. Surfaces shall be free from paint, rust, dirt, grease and corrosion.
- C. Holding down bolts or flange bolts shall not be used for bonding connections. Holes, if not provided, shall be drilled and tapped to suit the grounding bolt.
- D. Building structural steel, steel structures, vessels, tanks and other similar process equipment, which is not in direct contact with the building steel structures, shall be bonded as noted on the drawing.

3.2 ELECTRICAL SYSTEM SERVICE GROUNDING

- A. Service grounding of equipment (grounding) shall be by means of grounding the equipment to a continuous ground conductor, including all connections from source of power to the equipment. All grounding shall meet the requirements of the National Electrical Code.
- B. Where UL type "MC" cable is specified, the bare internal copper ground wire shall be used for service grounding.

- C. Service grounding shall be provided for all motors, housing of electrical equipment, transformers, transformer neutrals, grounding resistors, distribution equipment, lighting panel board and other similar equipment as required by the National Electrical Code and as indicated on the drawings.
- D. The neutral conductor of any electrical distribution system shall not be used as an equipment grounding conductor. System neutrals shall be grounded in accordance with the National Electrical Code.

3.3 INSTALLATION

- A. Immediately after installation, the equipment shall be grounded and bonded as indicated on the grounding layout and detail drawings.
- B. Exposed grounding or bonding conductors shall not be routed across sections where they may be subject to damage or interfere with the movement of equipment or personnel. In such cases and as required, the conductor may be embedded in the floor, protected by conduit or copper strap of equivalent size shall be used.
- C. Ground and bonding conductors shall be installed in a neat manner and rigidly supported by clips or straps at intervals not greater than 5 feet.
- D. Install conductors of size required by the National Electrical Code unless otherwise indicated or specified on the drawings.
- E. Power, control and instrumentation cable shields and/or sheaths shall be grounded in accordance with instructions contained in the cable schedules or wire termination sheets.
- F. When it is indicated on the drawings that the conduit system serves as the equipment service grounding, the means and continuity of ground shall be permanent, effective and maintained throughout. Threaded couplings or double locknuts and bushings shall be used at all boxes and equipment enclosures, including lighting fixtures. All flexible conduits shall be properly grounded through a grounding jumper and the necessary fittings. A separate ground conductor shall be installed in epoxy coated or PVC coated conduit, or other non-metallic duct runs and so connected to maintain the ground continuity of the conduit or duct system.
- G. Conduit expansion joints, not thoroughly bonded otherwise, shall be provided with approved bonding jumpers of not less than No. 6 AWG green insulated stranded copper.
- H. A minimum No. 6 AWG green insulated stranded copper ground conductor shall be run in all cable tray and bonded to each tray section at intervals not exceeding 50 ft.

END OF SECTION

SECTION 260534 CONDUITS

PART 1 GENERAL

1.1 SUMMARY

- A. This Section includes the conduit systems required, specified, and/or shown on Contract Drawings including conduits, fittings, boxes, hangers, and accessories being installed for Vermont Gas Systems, Inc. (Company).

1.2 REFERENCES

- A. Material and installation shall be in accordance with the latest revisions of the following codes, standards and specifications, except where more stringent requirements have been specified herein:
1. American National Standard Institute (ANSI)
 2. National Electric Code (NEC)
 3. National Electrical Manufacturers Association (NEMA)
 4. Underwriters Laboratories, Inc. (UL)

1.3 QUALITY ASSURANCE

A. Qualifications of Manufacturer

1. All equipment furnished under this Section shall be furnished by manufacturers who meet the quality, workmanship, and experience requirements as specified and approved by Company.

1.4 SUBMITTALS

A. General

1. Submittals and samples shall be submitted upon Company's request.
2. Prior to obtaining any material in connection with this Section, detailed shop drawings on all material shall be submitted upon Company's request.
3. Submittals shall contain a material list with manufacturer's name and data describing the material and showing its compliance with specifications and associated standards.

PART 2 PRODUCT

2.1 CONDUIT

A. Rigid Galvanized Steel Conduit (RGS)

1. Rigid metal conduit shall be galvanized steel, hot-dipped with zinc over the entire length, both exterior and interior including threads.
2. Each conduit shall have a coupling on one end and a thread protector on the other.

3. Conduit shall meet ANSI Standards C80.1 and C80.4 latest revisions. The conduit shall be manufactured by Allied Tube & Conduit Corporation, Pittsburgh Standard Conduit Company, Triangle PWC Co. or equal.
- B. Rigid PVC Coated Galvanized Steel (RPGS) Conduit
1. The conduit, prior to PVC coating, shall meet the requirements for RGS conduit above.
 2. A PVC coating shall be bonded to the outer surface of the galvanized conduit. The bond between the coating and the conduit surface shall be greater than the tensile strength of the coating. The inside surface of the conduit shall have a urethane coating.
 3. PVC coating thickness shall be not less than 40 mils.
 4. PVC coated RGS shall be manufactured in accordance with ANSI C80.1, UL-6, Federal Specification WW-C-581E and NEMA RN1 – PVC Externally Coated Galvanized Rigid Steel Conduit and Intermediate Metal Conduit standards.
 5. Manufacturers or Equal
 - a. Robroy
 - b. Thomas & Betts
- C. Electrical Metallic Tubing (EMT)
1. EMT shall be galvanized steel, hot-dipped with zinc over the entire length, both exterior and interior.
 2. EMT shall be in accordance with ANSI Standards C80-3 latest revisions.
 3. EMT shall be manufactured by Pittsburgh Standard Conduit Co., Allied Tube & Conduit Corporation, Triangle PWC Co., or equal.
- D. Flexible Conduit
1. Flexible metallic conduit (Greenfield) - Shall be hot dipped zinc galvanized flexible steel or aluminum and shall comply with UL Standard No. 1, latest revisions. Conduit shall be manufactured by Anaconda Metal Hose Company, Triangle PWC Co. or equal.
 2. Liquid-tight flexible metal conduit (Seal-tite) - Shall be constructed of flexible corrosion resistant zinc galvanized steel conduit with an extruded plastic jacket and built-in continuous copper ground strap under the jacket. Conduit shall be Type UA manufactured by Anaconda Metal Hose Company, Type LA manufactured by Electri-Flex Co. or equal.
 3. Liquid-tight Flexible Non-Metallic Conduit - Shall be constructed of corrugated flexible PVC. Fittings shall be identified for use with flexible non-metallic conduit. Flexible non-metallic conduit shall be Carflex as manufactured by Carlon or equal.
 4. Hazardous Area Flexible Metal Conduits - Flexible metal conduits installed in areas classified as Hazardous shall be Crouse-Hinds Series EC, Killark Series EK or equal.

2.2 JUNCTION, DEVICE AND PULL BOXES

A. Junction Boxes

1. Junction boxes and pull boxes shall be sized as required for the quantity and size of conductors to be installed within the box. Sizes shall comply with the requirements of the National Electric Code for wire bending space and radius.
2. Junction boxes installed in all non-hazardous open, wet areas or outdoors shall be NEMA type 4X with mounting lugs. Junction boxes shall have drilled and tapped holes for conduit terminations, gasketed covers secured by galvanized steel screws and drain holes.
3. Stamped Steel Junction Boxes -Junction boxes installed in areas approved for use with EMT conduit may be constructed of code-gaged galvanized steel.
4. Cast Junction Boxes -Junction boxes for use with RSC shall be constructed of hot dipped galvanized cast iron or copper free aluminum and shall be sized per NEC requirements. Boxes shall be manufactured by Crouse-Hinds Co., Killark Co. or equal.
5. Hazardous Area Junction Boxes - Junction boxes in areas classified as Hazardous shall be Series EJB or GU manufactured by Crouse-Hinds Co., Series XB or GR as manufactured by Killark Co., or equal.

B. Device Boxes for Outlets and Switches

1. Stamped Steel Device Boxes -In areas approved for use with EMT Conduit may be constructed of code-gage galvanized steel with required knockouts. Boxes shall be manufactured by Steel City Co., Raco Co. or equal.
2. Cast Device Boxes -In areas using exposed RSC boxes shall be constructed of hot dipped galvanized cast iron or copper free aluminum and sized per NEC requirements. Boxes shall be Series FD, manufactured by Crouse-Hinds Co., Series FD, manufactured by Killark Co., or equal (Use copper free aluminum boxes with RAC)
3. Hazardous Area Device Boxes -In areas classified as Hazardous, shall be Series ED manufactured by Crouse-Hinds; series SWB manufactured by Killark Co., or equal.

C. Pull Boxes

1. Pull boxes shall be used in dry locations only for pulling. No splicing of conductors shall be allowed. The boxes shall be constructed of galvanized steel, 12 gauge sheet metal, angle and frame members with welded joints. The box cover shall be gasketed and attached with stainless steel screws. A ground lug shall be provided, sized in accordance with the NEC.

2.3 CONDUIT OUTLET BODIES, FITTINGS, COUPLINGS AND EXPANSION COUPLINGS

A. Conduit Outlet Bodies

1. Conduit outlet bodies shall be used where required to permit ready fishing and withdrawing of wires. Conduit bodies not located in areas classified as Hazardous shall be gasketed. Bodies shall be of the cast iron or copper-free aluminum type. Bodies shall be Condulet series manufactured by Crouse-Hinds Co., Electrolet series manufactured by Killark Co., or equal.

B. Fittings and Couplings

1. EMT - All couplings and connectors for EMT shall be of the raintight cadmium plated, malleable iron gland compression type manufactured by O.Z. Gedney Co., Steel City Company, or equal.
2. Hazardous Areas - Seal off fittings in areas classified as Hazardous or Corrosive shall be Series EYS manufactured by Crouse-Hinds Co., Series E manufactured by Killark Co., or equal. Sealing compound shall be Chico manufactured by Crouse-Hinds or series SC manufactured by Killark or equal. Damming material shall be of the ceramic fiber type.
3. Flexible metallic conduit (Greenfield), Liquid-tight flexible metal conduit (Sealtite), and Liquid-tight Flexible Non-Metallic Conduit -Fittings shall be compatible with raceway material and in conformance with NEMA FB-1 and UL 514B. C. Expansion Couplings
 1. Expansion couplings shall be a water-tight, corrosion resistant coupling with flexible neoprene outer jacket, stainless steel jacket clamp, flexible copper ground strap, and internal hub bushing.
 2. Coupling shall compensate for the following movements:
 - a. Axial expansion or contraction
 - b. Angular misalignment
 - c. Parallel misalignment
 3. Coupling shall be Type XD as manufactured by Crouse-Hinds Company, Type DX as manufactured by O-Z Gedney Co. or equal.

2.4 CONDUIT SLEEVES

- A. Where conduits pass through the walls of structures, they shall be installed in suitable sleeves. Sleeves, installed in the outside walls of structures or elsewhere where watertightness is required, shall be cast iron and shall be equal to thruwall and floor seals manufactured by O.Z. Gedney Electrical Manufacturing Company, Inc. Types No. FSK, WSK, FSC or WSC as required, or Link-Seal as manufactured by Thunderline Corp. When Link-Seal is used, a wall sleeve, with waterstop, shall be installed. All other sleeves shall be galvanized steel pipe.

2.5 CONDUIT HANGERS AND SUPPORTS

A. General

1. Hangers and supports for conduits shall be adequate to support conduit systems with a minimum safety factor of 10.
2. All steel parts of the conduit support systems shall be galvanized, cadmium plated or PVC coated.
3. Perforated strap hangers will not be accepted.
4. Conduit supports shall be as manufactured by T&B (Steel City-Kindorf or Superstrut), Unistrut, Allied, Globe, or B-Line.

5. One hole malleable iron pipe clamps shall be hot dipped galvanized. Pipe spacers shall be of malleable iron and have a hot dip galvanized finish.
 6. Hanger rods shall be continuous thread and galvanized not less than 3/8" inch in diameter.
- B. Slotted Channel Framing: Cold-Formed Metal Channels with Continuous Slot.
1. Size of Channels: Nominal 1-5/8 by 1-5/8 inches, 12 gauge unless otherwise indicated or required for the application.
 2. Finish:
 - a. Indoor Dry Applications: Electro-plated zinc coating (Super-strut Gold- Galv, Kindorf Gold Galv-Krom, etc.).
 - b. Outdoor, wet applications: Hot dipped galvanized (Superstrut HDG, Kindorf HD, etc.).
 - c. Corrosive applications: PVC coated (Superstrut PVC, Kindorf "P", etc.).
 3. Fittings
 - a. Channel attachment nuts shall be prelocated in channel and be self supporting (spring type).
 - b. Conduit straps shall be of the notched type to fit channel with captured nut and bolt for tightening.
 - c. Beam clamps shall be provided with jaw openings to accommodate selected beam and provided with tapped holes and/or captured nuts for support of threaded rods.
 4. Manufacturer (refer to Finish above for correct product)
 - a. Kindorf B-900, 905 series
 - b. Superstrut A-1200, A-1200P series
 - c. Globe G-5812, G-5812PO series
 - d. B-Line B-22, B-22-1-7/8 H series
 - e. Unistrut P-1000, P-1000-HS series
 - f. Power Strut PS-200, PS-200-H-1-7/8 series
 - g. Equal

C. Fasteners

1. All fasteners shall be stainless steel or silicon bronze.
2. All expansion anchors shall be self-drilling type.

2.6 MISCELLANEOUS ACCESSORIES

A. Warning Tape

1. Tape shall be of the detectable type and shall consist of a polyethylene tape with aluminum foil coil. Tape shall be 6" wide and shall have the legend "CAUTION ELECTRIC LINE BURIED BELOW". Lettering shall be black, on a red background. Tape shall be Panduit HTDU6R-E, Seton 37236, or equal.

B. Duct Bank Conduit Spacers

1. Underground ductbank conduit spacers shall provide stability and consistent separation of conduits within duct banks. Spacers shall be sized for the conduits with which they are used. They shall provide both vertical and horizontal spacing with interlocking intermediate and base spacers.
2. The separation between adjacent conduits shall be in accordance with NEC Article 310.
3. Manufacturer:
 - a. Carlon
 - b. Equal

PART 3 EXECUTION

3.1 INSTALLATION

A. General

1. All interior conduit work shall be installed exposed except areas in which there is a finished ceiling, or as indicated on the Contract Drawings, "Room Finish Schedule," a finished ceiling will be installed. These areas shall have all conduit work concealed.
2. No exterior conduits shall be run exposed on outside walls of buildings or structures.
3. Minimum size shall be 3/4 inch unless specifically shown otherwise.
4. Terminations of metallic conduits shall be furnished with grounding bushings.
5. Where exposed conduit requires clamping to the building structure, clamps shall consist of galvanized iron one-hole pipe straps and expansion shields.
6. Support outlets; pull boxes and junction boxes separately from building construction, not from conduit.
7. Where exposed conduit is permitted, install conduit parallel to or at right angles with lines of building in neat and organized configurations.
8. Coordinate all conduit installations with other trades in advance of installation.
9. Plug conduit openings until wires are installed.
10. Conduit reducers shall not be allowed.
11. Expansion couplings shall be installed in conduits crossing buildings expansion joints.
12. Keep raceways at least 6 inches away from parallel runs of flues and steam or hot-water pipes. Install horizontal raceway runs above water and steam piping.
13. Complete raceway installation before starting conductor installation.
14. Install temporary closures to prevent foreign matter from entering raceways.

15. Protect stub-ups from damage where conduits rise through floor slabs. Arrange so curved portions of bends are not visible above the finished slab.
16. Make bends and offsets so ID is not reduced. Keep legs of bends in the same plane and keep straight legs of offsets parallel, unless otherwise indicated.
17. Install exposed raceways parallel or at right angles to nearby surfaces or structural members and follow surface contours as much as possible.
18. Run parallel or banked raceways together on common supports.
19. Make parallel bends in parallel or banked runs. Use factory elbows only where elbows can be installed parallel; otherwise, provide field bends for parallel raceways.
20. Join raceways with fittings designed and approved for that purpose and make joints tight.
21. Provide insulating bushings to meet NEC requirements.

B. Conduit Supports and Hangers

1. Conduit supports shall be spaced at intervals of 8 feet or less as required to obtain rigid construction.
2. Single conduits shall be supported by pipe clamps with clamp backs to raise conduits at least ¼ inch from the surface.
3. Multiple runs of conduits shall be supported on trapeze type hangers with steel horizontal members and threaded hanger rods.
4. Trapeze hangers shall be crossed braced to prevent spreading.
5. Conduit hangers shall be attached to structural steel by means of beam or channel clamps.
6. Supports located in corrosive areas and or where shown shall be PVC coated.

3.2 UNDERGROUND CONDUITS

- A. Conduits shall be buried to a minimum depth of 24 inches unless otherwise shown or specified.
- B. All buried conduits or groups of conduits shall have a warning tape buried 12 inches under finished grade and located directly over the centerline of the conduits. A second tape shall be buried 12 inches above the top of the highest conduit in the group. Where shown on the drawings, additional tapes shall be provided for ductbanks wider than 30 inches.
- C. Underground conduits exiting and entering structures shall have expansion couplings as specified.
- D. Where conduit is buried below grade, Contractor shall excavate, install, backfill and compact buried conduit prior to final compaction by General Contractor.
- E. Any Earthwork shall be in accordance with Division 31 – Earthworks.
- F. All conduits shall be cleaned and tested with a mandrel, prior to pulling cables.

G. The transition from the underground conduit system to the building interior conduit system shall occur at the first junction box, device, or equipment enclosure within the building. Conduit seals shall be provided at this location. Such seals shall minimize the circulation of air between the underground conduit system and the indoor enclosures. Seals shall be composed of Duct Seal sealing compound or similar non-hardening removable sealant.

H. Conduit bends in underground conduits shall have a minimum centerline radius as follows:

<u>Conduit Size</u>	<u>Radius (inches)</u>
3 inch	36
4 inch	42
5 inch	48

I. Conduit spacers shall be used when installing two or more underground conduits. Conduit spacers shall be located at intervals of 8 feet or less.

3.3 CONDUITS IN CORROSIVE AREAS

A. Where conduits pass through Corrosive Area walls and/or floors, seal off fittings as specified shall be installed to prevent gas leakage through conduit system.

3.4 CONDUITS IN HAZARDOUS AREAS

A. All conduit and equipment, in or through areas classified as Hazardous and all conduit and equipment for explosion proof work, shall be in accordance with the provisions of Article 501 of the National Electric Code for Class 1, Group D, Division 1 and 2 locations. Compound filled sealoff fittings as specified shall be installed as required.

3.5 CONDUIT TYPES

A. Rigid steel conduit shall be provided unless specifically noted otherwise on the Contract Drawings.

END OF SECTION

SECTION 260800 ELECTRICAL ACCEPTANCE TESTING

PART 1 - GENERAL

1.1 SCOPE OF WORK

- A. All electrical equipment, devices, electrical systems installed or provided by the Contractor under this Section shall be inspected and tested by the Contractor to ensure that they operate correctly for the specific installation and are operating as designed, based on the associated layout drawings.
- B. Refer to Section 3.0 for the Contractors' responsibilities related to inspection, testing, and commissioning of Company Furnished equipment.
- C. Any defects in the Contractor's workmanship disclosed by such tests shall be corrected by the Contractor at the expense of the Contractor and the work shall be tested again. All changes made in the installation shall be marked by the Contractor on a master set of "As-Built" drawings.
- D. When required by the Company, the Contractor shall provide at the Contractor's expense, equipment field Representatives for Contractor supplied equipment to perform equipment tests and train Company's operating staff.
- E. The Company will provide specialized commissioning personnel when required to complete the commissioning of Company pre-purchased equipment, wire terminations or for other specialized testing when and as needed. The Contactor will provide support personnel as needed during system checkout, start up, commissioning and acceptance testing.
- F. The Contractor shall provide instruments, meters, equipment and qualified personnel required to conduct tests and studies during and at the conclusion of the project.
- G. The Contractor shall implement a safety test and commissioning tagging procedure. The tags shall be dated and signed and shall indicate equipment checked, equipment tested, equipment energized and equipment commissioned.
- H. The Contractor shall perform all the equipment field tests as required to support Company commissioning plan.
- I. In general, the work shall be performed as outlined in Section 3.0 of this Specification.

PART 2 - PRODUCTS (NOT USED)

PART 3 - EXECUTION

3.1 INSPECTION

- A. The first stage shall be inspection of all equipment associated with the Contractor installation responsibility, including Company Pre-Purchased equipment and prefabricated buildings and Contractor supplied equipment.
- B. The Contractor shall confirm that all equipment and required quantities are complete and that equipment make and model specifications comply with the specified Project drawings and documentation.
- C. The Contractor shall record that all equipment is without defects or damage. Any deviations shall be recorded and the Company immediately informed of any discrepancy.

3.2 TESTING (PRE-COMMISSIONING)

- A. The second stage shall be Testing (Pre-Commissioning), prior to system power up, consisting of the following items.
 - 1. Check that the installation is complete and that all interconnections are correct.
 - 2. Check all power, control and signal wiring for continuity to ensure a clear path has been maintained. A formal sign off list of all wiring checks shall be provided to the Company prior to equipment energization.
 - 3. Perform all equipment testing and correct deficiencies.
 - 4. Provide assistance for third party commissioning and testing of the equipment.
 - 5. Perform function tests to confirm correct operation of all devices, subsystems and systems, and correct all deficiencies.

3.3 COMMISSIONING (START-UP)

- A. Commissioning (Start-up) Mainline Valve Station equipment and systems will be carried out by the Company or equipment manufacturer. The Contractor shall provide personnel throughout the commissioning period to assist and carry out any equipment adjustments, corrections or repairs, as required.

3.4 TEST PROCEDURES AND RECORD FORMS

- A. The Contractor shall work with Company, develop and submit for approval to the Company's Representative an outline of proposed inspection and test procedures, checklists and test record forms for each system or piece of equipment, prior to the start of testing.
- B. Test record forms shall include equipment number and system, method of testing, test equipment used, final readings obtained, adjustments made, test results and associated data.
- C. The Contractor shall submit inspection and test results including complete data on actual readings taken and corrected values, to the Company's Representative for approval after each test period.

3.5 TESTING AND PRE-COMMISSIONING OF COMPANY FURNISHED EQUIPMENT

- A. The Contractor shall provide testing and pre-commissioning of Company-furnished equipment. The Contractor shall submit for approval to the Company's Representative an outline of proposed tests for approval 30 days prior to the scheduled testing. The Contractor shall be responsible to thoroughly checkout, test and pre-commission all Company-furnished and Contractor supplied equipment and materials.
- B. Field Representatives shall be provided by the Company for specialized testing and commissioning of the Company furnished equipment.
- C. The Contractor will assist the Manufacturers' field representatives and Company's Field Personnel or commissioning representatives, as required, to complete final commissioning, startup and acceptance testing up to and including placing all equipment into Service.
- D. The Contractor shall assist in correcting any manufacturer defects in the Company-furnished equipment, as required by the Company. The Contractor will be reimbursed under the terms of the Contract.

3.6 GENERAL GUIDELINES

- A. All inspections and testing shall be performed in accordance with, OEM instructions, applicable codes and standards including but not limited to NEC, ANSI, IEEE, NFPA, NEMA, and OSHA.
- B. All testing and commissioning shall also be performed in accordance with the following guidelines, as a minimum:
 - 1. NETA Acceptance Testing Specifications for Electrical Power Distribution Equipment and Systems.
 - 2. Equipment Manufacturer Guidelines
- C. In general the Contractor's tests shall include the items listed in this specification and as further detailed in the following sections.
- C. Verify that the installed equipment and systems are installed correctly with respect to the site layout and interconnection drawings, schematics, and drawings and specifications, and bill of materials
- D. Check that all grounding terminals are connected to the correct grounding terminal and verify there are no ground loops.

3.7 DETAILED GUIDELINES

- A. The Contractor shall test all equipment or devices in accordance with the equipment manuals and manufacturer's instructions. The test shall include as a minimum the items covered in the following sections.

3.8 GROUNDING

- A. The grounding system shall be tested to ensure that all parts of the steel structures, motor frames, switchgear, trays, conduit and other electrical equipment will be at a potential in accordance with specifications.

3.9 LOW VOLTAGE (POWER & CONTROL) CABLES

- A. Testing of all low voltage cable shall be performed by Company personnel. Contractor shall retain the responsibility for correction of any faulty installation or replacement of defective equipment as identified by the Company.

3.10 FINAL TEST REPORTS AND ACCEPTANCE

- A. The Contractor shall submit the final approved test reports to the Company at the completion of the work under this Section.
- B. Inspection and approval of Contractor tests will not constitute a waiver of his responsibility for the successful operation of the installed systems.
- C. When all tests and commissioning have been completed to the satisfaction of the Company, the work shall be released by the Contractor to the Company.

END OF SECTION

SECTION 270000 DATA & COMMUNICATIONS

PART 1 - GENERAL

1.1 SCOPE OF WORK

- A. Provide data and communication system raceways, equipment mounting backboards, wall jacks and cabling as specified or indicated on the drawings.
- B. Data and communication systems shall include telephone systems and data/computer communications systems, as specified or indicated on the drawings.

1.2 STANDARDS

- A. Furnish communication systems cabling, and wall jacks listed by Underwriters' Laboratories as meeting National Electrical Code requirements and bearing the UL label where available for equipment specified.

1.3 SUBMITTALS

- A. Submit product data for the communication systems cabling and wall jacks. Include manufacturer model number and detailed product data to evaluate the products.

PART 2 - PRODUCTS

2.1 GENERAL

- A. System cabling, wall jacks and raceway systems shall be of the type indicated or specified on the drawings.

PART 3 - EXECUTION

3.1 GENERAL

- A. Provide and install the data and communication raceway system, including conduits complete with pull boxes, as specified or indicated on the drawings.
- B. All openings for cables or conduit that penetrate exit corridors or as indicated on the drawings shall be sealed to maintain the fire ratings and integrity of these areas.
- C. Provide pull lines in all spare conduits or ducts.

END OF SECTION

SECTION 310519.13 GEOTEXTILES

PART 1 - GENERAL

1.1 SUMMARY

- A. This Section includes the installation of separation/stabilization fabric as shown on the Contract Drawings and as specified herein.

1.2 QUALITY ASSURANCE

- A. The latest edition of the following standards, as referenced herein, shall be applicable:
 - 1. American Society for Testing and Materials (ASTM).

1.3 SUBMITTALS

- A. Product Data:
 - 1. Submit Manufacturer's material specifications, product literature and installation instructions.

1.4 DELIVERY, STORAGE, AND HANDLING

- A. Delivery:
 - 1. Deliver sufficient materials to the site to prevent interruption of the work.
 - 2. All materials shall be inspected by Contractor upon delivery. Products received at the site torn, with holes, deteriorated, or otherwise damaged will not be approved and shall be returned and replaced at no expense to the Owner.
- B. Storage:
 - 1. All material shall be stored in strict accordance with the manufacturer's recommendations and as approved by the Engineer.
 - 2. Do not store products directly on ground. Ship and store geotextile with suitable wrapping for protection against moisture and ultraviolet exposure. Store geotextile in way that protects it from elements, if stored outdoors, elevate and protect geotextile with waterproof cover.
- C. Handling:
 - 1. All material shall be handled in strict accordance with the manufacturer's recommendations and as approved by the Engineer.

PART 2 - PRODUCTS

2.1 WOVEN GEOTEXTILE

- A. Stabilization Fabric: To be used beneath and adjacent to the 12-inch transmission main in areas directed by the Construction Manager.
- B. Composed of polymeric yarn interlaced to form planar structure with uniform weave pattern.

- C. Calendered or finished so yarns will retain their relative position with respect to each other.
- D. Polymeric Yarn: Long-chain synthetic polymers (polyester or polypropylene) with stabilizer or inhibitors added to make filament resistant to deterioration due to heat and ultraviolet light exposure.
- E. Physical Properties: Conform to requirements noted below:

Property	Design Value	Test Method
Tensile Strength	315 lbs	ASTM D4632
Elongation	12%	ASTM D4632
Trapezoidal Tear	113 lbs	ASTM D4533
CBR Puncture Strength	900 lbs	ASTM D6241
A.O.S.	40 (US Sieve)	ASTM D4751
Permittivity	.05 sec ⁻¹	ASTM D4491

PART 3 - EXECUTION

3.1 GENERAL

- A. The Contractor shall be responsible for the installation and seaming of geotextile fabric in accordance with the specifications and the manufacturer's recommendations, as approved by the Engineer.

3.2 SUBGRADE PREPARATION

- A. Surfaces to be covered with geotextile fabric shall be as directed by the Construction Manager. The surface to be covered shall be firm and unyielding, with no sudden changes or breaks in grade. There shall be no standing water or excessive moisture on the surface when the fabric is placed.
- B. The compacted subgrade shall be maintained in a smooth, uniform and compacted condition during installation of the fabric.

3.3 GEOTEXTILE INSTALLATION

- A. The fabric shall be cleaned of all debris or other materials that may negatively affect the fabric's performance.
- B. Mechanical equipment shall not be permitted to operate directly on the fabric unless authorized to do so by the manufacturer and approved by the Engineer.

C. Geotextile Placement

1. Fabric shall be placed as recommended by the manufacturer and approved by the Engineer on surfaces which have been prepared to conform with these Specifications and found acceptable for fabric installation.
2. The fabric shall be placed as smooth and wrinkle-free as possible.
3. All areas of fabric damaged during installation as determined by the Engineer shall be repaired or replaced by the Contractor as specified at no additional cost to the Owner. Should the fabric be damaged during any step of the installation, the damaged section shall be repaired by covering it with a piece of fabric which extends at least 24 inches in all directions beyond the damaged area. The fabric shall be secured by sewing or bonding as approved by the Engineer.

4. At time of installation, fabric will be rejected if it has defects, ribs, holes, flaws, deterioration, or damage incurred during manufacture, transportation, handling, or storage. Damaged materials shall be removed and replaced at no additional cost to the Owner.
5. Fabric shall be protected at all times during construction from contamination by surface runoff and any fabric so contaminated shall be removed and replaced with uncontaminated fabric.

D. Seams and Overlaps of Geotextile:

1. All overlaps shall be a minimum of eighteen (18) inches.

3.4 COVER MATERIALS OVER GEOTEXTILES

- A. Granular materials shall be placed on geotextiles as shown on the Contract Drawings. During back-dumping and spreading, a minimum depth of 6 inches of granular material shall be maintained at all times between the fabric and wheels of trucks or spreading equipment. All equipment used in spreading or traveling on the cover layer for any reason shall exert low ground pressures and shall be approved by the manufacturer and Engineer. Dozer blades, etc. shall not make direct contact with the fabric; however, if tears occur in the fabric during the spreading operation, the granular material shall be cleared from the fabric and the damaged area repaired as previously described.
- B. The granular material shall be spread in the direction of fabric overlap. Large fabric wrinkles which may develop during the spreading operations shall be folded and flattened in the direction of the spreading. Occasionally, large folds may reduce the fabric overlap width. Special care shall be given to maintain proper overlap and fabric continuity.
- C. All equipment spreading cover material or traveling on the cover layer shall avoid making sharp turns, quick stops or quick starts.
- D. Fabric shall be covered as soon as possible after placement to minimize exposure to sunlight. Fabric shall not be exposed for more than 5 days.

3.5 DISPOSAL OF SCRAP MATERIALS

- A. On completion of installation, the Contractor shall legally dispose of all trash and scrap material off-site or in a location approved by the Owner and Engineer, remove equipment used in connection with the work herein, and shall leave the premises in a neat acceptable manner.

END OF SECTION

SECTION 312000 EARTH MOVING

PART 1 - GENERAL

1.1 SUMMARY

- A. This Section includes the preparation of the site, protection, excavation, embankment, drainage, dewatering, for site grading, excavating, and backfilling as shown on the Drawings, and as herein specified.
- B. The Contractor shall accept the site in the condition in which it exists at the time of the award of the Contract.
- C. The Construction Manager shall determine the suitability of materials that are to be used in the work and should any materials encountered be unsatisfactory for the purpose intended, they shall be removed from the site at the Contractor's expense.

1.2 QUALITY ASSURANCE

A. Reference Standards:

- 1. The latest edition of the following standards, as referenced herein, shall be applicable.
 - a. Vermont Agency of Transportation (VT AOT), 2011 Standard Specifications for Construction Book.
 - b. "Standard Specifications for Highway Materials and Methods of Sampling and Testing, American Association of State Highway and Transportation Officials (AASHTO)."

- B. The Contractor shall comply with the requirements for soil erosion and sedimentation control, and other requirements of governmental authorities having jurisdiction, including the Vermont Agency of Natural Resources, Department of Environmental Conservation (DEC) and United States Army Corp of Engineers – New England Branch.

- C. The Contractor shall provide and pay for all costs in connection with an approved independent testing facility to determine conformance of soils and aggregate with the specifications in accordance with Section "Quality Requirements."

1.3 SUBMITTALS

A. Samples:

- 1. The Contractor shall furnish earth materials to the testing laboratory for analysis and report, as directed by the Engineer, or as outlined in the specifications.

B. Test Results:

- 1. The testing laboratory shall submit written reports of all tests, investigations, and recommendations to the Contractor and the Engineer.

1.4 PROJECT REQUIREMENTS

- A. Notify the Engineer of any unexpected subsurface condition.
- B. Protection of Existing Utilities:
 - 1. Locate existing underground utilities in areas of work. If utilities are to remain in place, provide adequate support and protection during earthwork operations, comply with OSHA requirements.
 - 2. Coordinate interruption and/or termination of utilities with the utility companies and the Owner.
 - 3. Provide a minimum of forty-eight (48) hours notice to the Owner and Utility and receive written notice to proceed before interrupting any utility.
 - 4. Repair any damaged utilities as acceptable to the Construction Manager, at no additional cost to the Owner.
- C. Protection of Persons and Property:
 - 1. Barricade open excavations occurring as part of this work, and post with warning signs and lights.
 - 2. Operate warning lights as recommended by authorities having jurisdiction.
 - 3. Protect structures, utilities, sidewalks, pavements, and other facilities from damage caused by settlement, lateral movement, undermining, washout and other hazards created by earthwork operations.

PART 2 - PRODUCTS

2.1 MATERIALS

- A. Select Granular Material: Sound, durable, sand, gravel, stone or blends with these materials, free from organic, frozen, or other deleterious materials, conforming to the requirements of VTAOT Div. 301 - Subbase and meeting the following gradation requirements Subsection Div. 704.05 – Crushed Gravel for Subbase:

	<u>Sieve</u>	<u>Percent Passing</u>
Grading Course	4"	95 to 100
	No. 4	25 to 50
	No. 100	0 - 12
	No. 200	0 - 6
Fine	2"	100
	1-1/2"	90 to 100
	No. 4	30 - 60
	No. 100	0 to 12
	No. 200	0 - 6

- B. Selected Fill: Sound, durable, sand, gravel, stone, or blends of these materials, free from organic, frozen or other deleterious materials, conforming to the requirements of VTAOT Div. 301 - Subbase and meeting the following gradation requirements for Subsection 704.06 – Dense Graded Crushed Stone for Subbase:

<u>Sieve</u>	<u>Percent Passing</u>
3/4"	100
1/2"	70 to 100
No. 4	50 to 90
No. 100	0 to 12
No. 200	0 – 6

1. Fines passing No. 200 shall be non-plastic.
 2. Particle size analysis shall show no gap grading.
- C. Bank Run Gravel: Shall conform with Section 704.04 of the VTrans Standard Specification for Construction.
- D. Bank Run Sand: Shall conform with Section 703.03 of the VTrans Standard Specification for Construction.
- E. ¾-inch Crushed Stone: Shall conform with Section 704.02B of the VTrans Standard Specification for Construction
- F. 1-inch Crushed Stone: Shall conform with Section 704.02C of the VTrans Standard Specification for Construction

PART 3 - EXECUTION

3.1 PRECONSTRUCTION MATERIAL QUALIFICATION TESTING

- A. A 30-pound minimum representative sample shall be obtained from each potential borrow source. If different material gradations are known to exist in the pit, samples shall be obtained for each material. Each sample shall be mixed thoroughly and reduced to test specimen size, in accordance with AASHTO T87. The test shall be performed in the order shown. Failure to pass any test is grounds for disqualification and shall lead to cessation of the test program for that material.
1. Particle Size Analysis:
 - a. Method: ASTM D422.
 - b. Number of Tests: One (1) per potential source.
 - c. Acceptance Criteria: Gradation within specified limits.
 2. Maximum Density Determination:
 - a. Method: ASTM D1557, Modified Proctor.
 - b. Number of Tests: One (1) per potential source.
 3. Re-establish gradation and maximum density of fill material if source is changed during construction.

3.2 PREPARATION

- A. Establish required lines, levels, contours and datum.
- B. Maintain benchmarks and other elevation control points. Re-establish, if disturbed or destroyed, at no additional cost to the Owner.
- C. Establish location and extent of utilities before commencement of grading operations.

3.3 EXCAVATION

- A. Excavation shall consist, in general, of the excavation of whatever substance is encountered to the lines, grades and sections shown on the Drawings, including excavation as necessary for grading and other similar features.
- B. All suitable materials removed in excavation shall be used in the construction of embankments, subgrade, shoulders, slopes and at such other places as directed. The Engineer shall be the sole judge of what constitutes suitable material.

3.4 During construction, the grading operations shall be executed in such a manner that the excavation will be well drained at all times. All grading shall be finished on neat, regular lines conforming to the sections and contours shown on the Drawings.

- A. Removal of materials beyond the indicated subgrade elevations, without authorization by the Engineer, shall be classified as unauthorized excavation and shall be performed at no additional cost to the Owner.
- B. Excavation shall be performed in proper sequence with all other associated operations.
- C. Maintain the slopes of excavation in a safe condition until completion of the grading operation.
- D. All excavation work shall be inspected and approved by the Engineer before proceeding with construction.
- E. Any excess excavation shall be removed from the site to disposal areas at the Contractor's expense.

3.5 FILL

- A. When native soil conditions are not acceptable for pipe bedding and pipe envelope backfill, "bank run sand" shall be utilized.
- B. When native soil conditions are not acceptable for trench backfill, "bank run gravel", "selected granular fill", "selected fill", or approved equal backfill shall be utilized.
- C. All site fill not included within the trench limits shall be "selected fill" unless otherwise shown on the Drawings, or directed by the Engineer. "Select granular fill" shall be placed in lieu of selected fill where directed by the Engineer.
- D. Before depositing fills, the surface of the ground shall be cleared of all refuse, brush and large stones. Conform to Section "Site Clearing."
- E. Prior to placing fill over undistributed material, scarify to a minimum depth of six (6) inches.
- F. Where fills are made on hillsides or slopes, the slope of the original ground upon which the fill is to be placed shall be plowed or scarified deeply or where the slope ratio of the original ground is steeper than 2 horizontal to 1 vertical, the bank shall be stepped or benched.

- G. A thoroughly and satisfactorily subgrade is defined as having a minimum dry density of 95 percent of the maximum density of the material used. The subgrade material shall be compacted at a moisture content suitable for obtaining the required density.
- H. Place backfill and fill materials in layers not more than 12" in loose depth unless shown otherwise on the Drawings. Lift height shall be governed by the ability of the compaction equipment to obtain the required compaction with 12" as a maximum lift height. Before compaction, moisten or aerate each layer as necessary to facilitate compaction to the required density. Do not place backfill or fill material on surfaces that are muddy, frozen, or contain frost, ice, ponded water or extraneous debris.
- I. When work is suspended during periods of freezing weather, measures shall be taken to prevent fill already in place from freezing. Upon resumption of work after any inclement weather, prepare the exposed surface by proof rolling to identify any zones of soft/loose soils. Soft/loose materials or frozen soils shall be removed and replaced by compacted granular fill.
- J. Moisture Control:
1. Where fill or backfill must be moisture conditioned before compaction, uniformly apply water to the surface and to each layer of fill or backfill. Prevent ponding or other free water on surface subsequent to, or during, compaction operations.
 2. Remove and replace, or scarify and air dry, soil that is too wet to permit compaction to specified density. Soil that has been removed because it is too wet to permit compaction may be stockpiled or spread and allowed to dry. Assist drying by discing, harrowing or pulverizing, until moisture content is reduced to a value which will permit compaction to the percentage of maximum density specified.
- K. All fill shall be thoroughly and satisfactorily compacted to 95 percent of the maximum dry density of material used when under pavements or roadways. All other fill shall be thoroughly and satisfactory compacted to 90 percent of the maximum dry density.

3.6 GRADING

- A. The present and finished grade lines are shown on the contract drawings. Grade over the entire area, as shown on the drawings, shall be to the finished subgrade levels. Upon completion of this work, all debris shall be cleaned out and removed from the premises.
- B. All cutting, filling, backfilling and grading necessary shall be done to bring the area to the following grade or subgrade levels:
1. For roadway surface areas; to the finished subgrade levels specified on the contract drawings.
 2. For areas to be topsoiled and seeded; to within 6-inches of the finished grade.
 3. For other surface treatments; as detailed on the Drawings.
- C. Sufficient grading must be done during the progress of the work so that the entire site shall be well drained and free from water pockets.
- D. Finish grading, including dressing swales, cleaning up excess footing excavation, dressing terraces, disposing of excess material and all other work necessary to prepare the site for topsoil and seeding shall be done after construction of structures and roadway surface areas is substantially complete.

3.7 COMPACTION EQUIPMENT

- A. Compaction equipment used for the Work is subject to approval by the Engineer. Any equipment not originally manufactured for compaction purposes and equipment which is not in proper working order

will not be approved. Furnish manufacturer's specifications covering data not obvious from a visual inspection of the equipment and necessary to determine its classification and performance characteristics.

B. Vibratory Drum Compactors: A self-propelled compactor classified for use according to the developed compactive force rating per linear inch of drum width (PLI). The actual operating frequency of the compactor will determine the PLI rating.

1. Approval of vibratory compactors usage is contingent upon proper operation of equipment at all times during compaction operations.
2. Compaction equipment other than vibratory drum compactors may be used subject to the approval of the Owner's Representative. Submit specifications at least 2 weeks prior to use of this equipment.
3. Do not use vibratory drum compactors after concrete is poured.

3.8 DRAINAGE AND DEWATERING

- A. Prevent surface, subsurface or ground water from flowing into excavation and from flooding project area, as well as surrounding areas.
- B. Do not allow water to accumulate in excavations. Remove water to prevent soil changes detrimental to the stability of subgrades.
- C. Provide and maintain the pumps, well points, sumps, suction and discharge lines, and other dewatering components necessary to convey water away from excavations.
- D. Provide and maintain temporary drainage ditches and other diversions outside excavation limits to convey rain water and water removed from excavations by dewatering, to collection or run-off areas.
- E. Dewatering operations shall be as directed by the Engineer and performed in accordance with Section "Dewatering."

3.9 FIELD QUALITY CONTROL

- A. Notify the Engineer at least one (1) working day in advance of all phases of filling and backfilling operations.
- B. Compaction testing shall be performed to ascertain the compacted density of the fill and backfill materials in accordance with the following methods:
 1. In-place relative density:
 - a. Method: AASHTO T238, Nuclear Method
 - b. Number of Tests: One (1) per 12" vertical lift.
- C. The Construction Manager may direct additional tests to establish gradation, maximum density, and in-place density as required by working conditions, at the Contractor's expense.
- D. Acceptance Criteria: The sole criterion for acceptability of in-place fill shall be in situ dry density. Minimum dry density for all fill or backfill under pavement or roadways shall be 95 percent of the maximum dry density (90 percent for all other areas). If a test fails to qualify, the fill shall be further compacted and re-tested. Subsequent test failures shall be followed by removal and replacement of the material. (See VTAOT Specs. 203.11 (d) regarding moisture content to be determined by Engineer)

3.10 CLEAN UP

- A. Provide and maintain protections or newly filled areas against damage. Upon completion or when directed, correct all damaged and deficient work by building up low spots and remove temporary protections, fencing, shoring and bracing.
- B. Remove all surplus excavated material not required for filling and backfilling and legally dispose of same away from premises.
- C. Leave the premises and work in clean, satisfactory condition, ready to receive subsequent operations.

END OF SECTION

DRAFT - NOT FOR CONSTRUCTION

SECTION 312316.26 ROCK REMOVAL

PART 1 - GENERAL

1.1 SUMMARY

- A. This Section includes drilling, blasting, excavation, removal and disposal of rock as necessary for the installation of the Work, and as indicated and specified herein.

1.2 REFERENCES

- A. The latest edition of the following standards, as referenced herein, shall be applicable.
1. "Structure Response and Damage Produced by Ground Vibration From Surface Mine Blasting," U.S. Bureau of Mines Publication RI 8507.

1.3 DEFINITIONS

- A. **Rock:** Limestone, sandstone, shale, granite, quartz, and formations of other varying mineral or aggregate composition in solid beds or masses in its original or stratified position that exceed 1 cubic yard and that cannot be excavated with one of the following
1. A crawler tractor having a minimum draw bar pull rated at not less than 71,000 lbs. (Caterpillar D9N or equivalent), and occupying an original volume of at least 1 cubic yards or more.
 2. A backhoe having a break out force rated at not less than 44,000 lbs. (Caterpillar 235D or equivalent), and occupying an original volume of at least 1 cubic yards.
- B. **Rock Excavation:** Removal of rock by means of drilling, blasting, or use of pneumatic tools or expansive chemical agents. Removal of materials which, in the opinion of the Construction Manager, can be loosened and excavated by mechanical means (ripping, etc.) including frozen materials, soft laminated shale or hardpan, pavements, curbs and similar materials shall be classified as earth excavation with the exception of rock face scaling. Do not proceed with the excavation of this material until the Construction Manager has classified the materials as common excavation or rock excavation and has taken cross sections as required. Failure on the part of the Contractor to remove such material, notify the Construction Manager, and allow ample time for classification and cross sectioning of the undisturbed surface of such material will cause the forfeiture of the Contractor's right of claim to any classification or volume of material to be paid for other than that allowed by the Construction Manager for the areas of work in which such deposits occur.
- C. **Unauthorized Excavation:** Removal of any material beyond horizontal and vertical limits indicated on the Drawings or as specified herein, without the prior approval of the Construction Manager.
- D. **Scaling:** Scaling shall be considered the removal of loose and broken rock from the face of rock cuts by mechanical means. Scaling shall be included in Rock Excavation item as defined above.
- E. **Blasting Specialty Contractor:** A subcontractor approved by the Construction Manager retained by the Contractor performing all work related to drilling and blasting for rock excavating.

- F. Independent Specialty Condition Survey Contractor: A subcontractor approved by the Construction Manager retained by the Contractor to perform pre and post blast condition surveys of nearby structures.
- G. Independent Specialty Condition Seismic Survey Contractor: A subcontractor approved by the Construction Manager retained by the Contractor to perform seismic vibration monitoring on-site and off-site at locations specified or designated by the Construction Manager.
- H. Pre-splitting: A controlled blasting method in which a smooth excavation face is created by simultaneously blasting a single row of closely spaced holes along the excavation line prior to blasting the remainder of the holes in the blast pattern. Pre-splitting blast holes shall be a minimum of 3 inches diameter at a center-to-center spacing not exceeding 24 inches.
- I. Line Drilling: A controlled blasting method in which a single row of closely spaced, unloaded holes are drilled along the neat excavation line to create a plane of weakness which the primary blast can break. Center-to-center spacing of line drilled holes shall be no more than twice the hole diameter.

1.4 SUBMITTALS

A. General:

1. Submit Specialty Contractors' qualifications, to the Construction Manager for approval.
2. Submit work plans, site safety plans, proposed equipment, and a detailed outline of intended rock removal procedures and any other information listed in this specification to the Construction Manager for approval. This submittal shall not relieve the Contractor of complete responsibility for the successful performance of the method(s) used.

B. Blast Plan:

1. The Blasting Specialty Contractor shall develop a detailed written blast design plan complying with the applicable requirements in NFPA 496, "Explosive Materials Code". A copy of the blast design plan shall be furnished to the Construction Manager two weeks prior to blasting operations and shall include the types of explosive and sizes of charge to be used in each area of rock removal, types of blasting mats, sequence of blasting operations, and procedures that will prevent damage to site improvements and structures on Project site and adjacent properties. .

C. Pre and Post Blast Surveys:

1. Pre- and post-blast conditions surveys shall be completed for all nearby properties where ground vibrations will be perceptible (peak particle velocity greater than 0.1 in./sec.) prior to blasting. This survey shall include, at a minimum, all properties within a 600 ft. radius surrounding the construction area and any critical structures of interest as determined by the Construction Manager. Prior to execution of the survey, a plan noting structures to be surveyed and survey methods shall be submitted to the Construction Manager for approval.
2. During these surveys, all structures and installations, buildings, bridges, water sources, storage tanks, utilities and other significant features, etc., shall be examined and photographed as necessary. Pre and post blast surveys shall include all accessible indoor areas and outdoor sections of surveyed structures. Photographs accompanied by audio tape or written field reports, or narrated video tape shall be included as part of the

surveys. A written survey summary shall also be included with all submittals. Within thirty (30) days of completion of this survey and prior to blasting, a pre-blasting conditions survey report shall be submitted to the Construction Manager and Owner. Within thirty (30) days after completion of blasting operations, the Independent Specialty Condition Survey Contractor shall conduct a post-blasting survey of all the same properties. The post-blast conditions survey report shall be submitted to the Construction Manager and Owner within thirty (30) days.

3. Well testing shall include both quality and flow testing, both pre-blast and post-blasting, when within 600 feet of the blasting activities. Well quality shall be tested utilizing the Vermont Department of Health "Kit A", "Kit C", and "Kit RA". Well quantity shall be tested by a licensed Vermont Well Driller utilizing the "blow down" method.

D. Seismic Monitoring Plan:

1. The Seismic Specialty Contractor shall develop a written monitoring plan detailing equipment to be used, monitoring locations, seismic event record format example, and schedule. A copy of the seismic monitoring plan shall be furnished to the Construction Manager two weeks prior to blasting operations.

E. Seismic Monitoring Records:

1. A written seismic monitoring record of each monitoring/blast event shall be submitted to the Construction Manager the work day following each blast event. Monitoring shall be performed at the nearest point of the nearest structure to the blast, unless directed otherwise by the Construction Manager. The record shall include at least the following information:

- a. Location of seismic vibration and sound level transducers;
- b. Peak Particle Velocity (PPV), Vibration Frequency (Frq), Peak Displacement (PD) and Peak Particle Acceleration (PPA) in the longitudinal, vertical, and transverse directions as well as Resultant PPV and Peak Sound levels (dB) for each event;
- c. Seismograph printout;
- d. Date and time of blast event;
- e. Distance from seismograph to the blast
- f. Monitored time interval.

2. The Seismic Specialty Contractor shall immediately inform the Construction Manager if vibration levels or sound levels exceed specified values.

F. Blast Hole Records:

1. Written records of each blast shall be submitted to the Construction Manager the work day after each blast event and shall include at least the following items:
 - a. Surface elevation;
 - b. Location;

- c. Number of holes;
- d. Depth of holes;
- e. Water conditions in each hole (if any);
- f. Quantity and type of explosives used;
- g. Maximum quantity of explosives per delay and number of delays. A delay shall be considered detonations separated by a minimum of 8 milliseconds;
- h. Detonation delay pattern;
- i. Stemmed length of hole;
- j. Date and blast time.

G. Log of Complaints:

- 1. A log of all complaints and responses resulting from blasting operations shall be kept by the Contractor's designated contact person. The log should include as a minimum the following information: name and address of person registering complaint/inquiry; time and date when annoyance occurred; time and date when complaint/inquiry filed; nature of complaint/inquiry; action taken by contact person; follow-up action. A copy of all complaints and responses shall be submitted to the Owner and Construction Manager by the following work day.

H. Site Safety Plan:

- 1. Site safety shall be coordinated through the Contractor's office. A written safety plan shall be developed and distributed to all subcontractors, the Owner and the Construction Manager.

I. Certifications/Licenses:

- 1. One (1) copy of each certificate, license, permit and proof of insurance required by this specification shall be submitted to the Construction Manager after award of contract and prior to commencement of work.

J. Quality Assurance:

- 1. The Contractor shall use the services of an experienced Specialty Contractor to perform all blasting operations.
- 2. The Blasting Specialty Contractor and the blasting foreman shall be regularly engaged in blasting work of similar magnitude and scope and shall be approved by the Construction Manager to perform this project. A list of prior work experience for the Blasting Specialty Contractor and foreman shall be submitted with the bid.

1.5 REGULATORY REQUIREMENTS

- A. The Blasting Specialty Contractor shall obtain all required permits, certificates, and licenses (City, State, Local etc.) prior to the commencement of any blasting operations.
- B. Blasting safety procedures and operations shall comply with Title 29 Code of Federal Regulations

- C. Part 1910.109, and all other applicable state and local standards and regulations.

1.6 PROJECT/SITE CONDITIONS

- A. Existing Conditions: Existing physical conditions as defined for design purposes are noted on the Drawings and are described in the Information Available to Bidders section of the Contract Documents.

1.7 SEQUENCING AND SCHEDULING

- A. Work associated with blasting shall be performed in accordance with the following general sequence:
 1. Complete and submit pre-blast survey;
 2. Notify all appropriate authorities having jurisdiction of proposed activities;
 3. Prepare site for blasting;
 4. Notify affected utility owners, operators and nearby residents as required in Part 3 - Execution;
 5. Complete test blast program simultaneously with seismic monitoring;
 6. Complete production blasting work simultaneously with seismic monitoring;
 7. Complete and submit post-blast survey.

1.8 MAINTENANCE

- A. Any and all damage caused by the Blasting operations shall be repaired or replaced to the Owner's and Construction Manager's satisfaction at the expense of the Blasting Specialty Contractor within thirty (30) days of completion of the Post-Blast Survey.

PART 2 - PRODUCTS

2.1 GENERAL

- A. No perchlorates shall be acceptable in any blasting products. All caps, charges and other applicable blasting materials shall be perchlorate-free.

PART 3 - EXECUTION

3.1 PREPARATION

- A. All personnel working on-site shall be instructed as to the nature, times, duration, site safety and warning signals concerning blasting operations.
- B. Local residents within the Pre-Blast Survey area shall be notified at least 48 hours prior to initial blasting operations and provided with the name and phone number of one full-time, on-site contact person designated by the Contractor for handling all complaints and inquiries. Residents shall be notified of blast schedule and changes on at least a weekly basis throughout the duration of blasting operations. Residents shall also be informed of warning signals identifying an upcoming blast and all-clear signals following completion of a blast as outlined in Site Safety Plan.

- C. Explosives and blasting caps shall not be brought onto the site or used without appropriate permits, licenses, certificates and/or prior written approval of authorities having jurisdiction. The Specialty Contractor is solely responsible for handling, storage, and use of explosive materials in accordance with regulatory and permit requirements.

3.2 ROCK REMOVAL

- A. Remove rock as indicated by the Drawings and as necessary for the installation of the Work. Provide sufficient clearance, within the limits specified, for the proper execution of the Work.
- B. Remove rock to lines and subgrade elevations indicated to permit installation of permanent construction without exceeding the following dimensions:
 - 1. 24-inches outside of concrete forms other than at footings.
 - 2. 12-inches outside of concrete forms at footings.
 - 3. 6-inches outside of minimum required dimensions of concrete cast against grade.
 - 4. Outside dimensions of concrete walls indicated to be cast against rock without forms or exterior waterproofing treatments.
 - 5. 6-inches beneath bottom of concrete slabs on grade.
 - 6. 9-inches beneath pipe in trenches, and 12-inches on each side of the pipe..
- C. Fill areas of over-excavated rock to the proposed subgrade elevations as required by Drawings with selected fill in accordance with Section "Trenching and Backfilling" or Section "Earth Moving" Over-excavation beneath foundations shall be filled with footing concrete ($f^1 = 3000$ psi minimum).
- D. A test blast shall be performed and monitored prior to commencement of production blasting. Test blast records and seismic records shall be reported to the Construction Manager prior to continuation of blasting. If test blast indicates that the blasting plan requires modification, such changes shall be reported to the Construction Manager immediately. Reporting this information to the Construction Manager shall not relieve the Contractor(s) of complete responsibility for the successful performance of the method(s) used, nor shall the reporting constitute approval by the Construction Manager for the proposed plans.
- E. The Seismic Specialty Contractor shall monitor the vibrations and sound levels caused by Blasting.
- F. Seismic monitoring shall be performed for each blast, unless specified otherwise. Monitoring shall be performed at the nearest structure or at locations designated by the Construction Manager on each field day.
- G. If the ground vibrations exceed specified tolerances the Blasting Specialty Contractor's operations shall cease immediately and remain stopped until the Blasting Specialty Contractor has taken all necessary additional measures to protect adjacent property and personnel.
- H. The Blasting Specialty Contractor shall use steel or rubber blasting mats as may be necessary to control fly-rock.

3.3 EXCAVATION TOLERANCES

- A. Blast hole drilling and overblast beyond the vertical limits indicated shall be less than 1.5 feet.

- B. Rock removal limits shall include all materials defined as rock whether removal is accomplished by mechanical means (ripping, etc.) or by drilling and blasting.

3.4 VIBRATION AND SOUND TOLERANCES

- A. Blast vibrations shall be maintained within safe limits as defined by the Peak Particle Velocity (in./sec.) vs. Blast Frequency (Hz) as described in the United States Bureau of Mines Publication RI-8507, Appendix B (“Siskind Curve”).
- B. Sound levels shall not exceed 130dB at the nearest structure.
- C. Vibrations levels at new concrete structures shall be limited to the following levels:

<u>Age of Concrete (days)</u>	<u>Maximum Allowable PPV</u>
Less than 1/2	0.1 (in./sec.)
1/2 to 7	1.0 (in./sec.)
Greater than 7	2.0 (in./sec.)

END OF SECTION

DRAFT - NOT FOR CONSTRUCTION

SECTION 312319 DEWATERING

PART 1 - GENERAL

1.1 SUMMARY

- A. This section includes provisions for a dewatering system to continuously lower and control groundwater levels and hydrostatic pressures in order to maintain near-dry conditions for construction of the work as shown on the plans and specified herein.
- B. All dewatering operations shall be in accordance with project permits and the Erosion Prevention and Sediment Control Plans.

1.2 SUBMITTALS

- A. Submit the following :
 - 1. Description: of proposed dewatering system.
 - 2. Layout: of dewatering system, including location of sumps, deep wells, well points, header pipes, pumps, discharge lines and observation wells.
 - 3. Details: of dewatering system, including installation methods for deep wells, well points and observation wells, depths of wells, material descriptions, pipe sizes, intake screen sizes, and pump capacities.
 - 4. Estimate: of time required to lower groundwater levels after start of pumping

1.3 JOB CONDITIONS

- A. Site soil boring data and samples, soil laboratory testing, and any soil reports shall be made available to prospective bidders for study and review. Bidders must make their own interpretation of subsurface conditions that may affect methods or the cost of construction of the Work.

PART 2 - PRODUCTS

2.1 DEWATERING SYSTEM

- A. Provide a dewatering system of adequate size and capacity to lower and maintain the groundwater at the specified level. The system shall include standby pumps and power source for continuous operation.
 - 1. Dewatering system shall consist of wellpoints, deep wells, cut-off walls, riser pipes, swing joints, header lines, valves, pumps, discharge lines, and all other necessary fittings, accessories and equipment for a complete operating system. Provide hole punches, sand backfill and clay plugs as required by soil conditions.
- B. Sand: Clean concrete sand conforming to ASTM C 33.

PART 3 - EXECUTION

3.1 INSTALLATION

- A. Install the dewatering system in accordance with approved Shop Drawings and as required by site conditions. Locate elements of the system to allow a continuous dewatering operation without interfering with the installation of any permanent project Work.

3.2 OPERATION

- A. Keep the system in continuous operation from the time excavation is started in the dewatering area (or before if required by site conditions to lower the groundwater to the elevations specified) until the time backfilling is completed at least 2 feet above the normal groundwater level.

- 1. Do not discontinue dewatering operations without specific approval from the Engineer.

- B. In the event excavation proceeds subsequent to dewatering as specified above, and the groundwater level is found to be within two feet of the excavation, the dewatering Contractor shall immediately continue to dewater as specified herein, including, but not limited to, additional dewatering and monitoring facilities, at no additional cost to the Owner. The excavation shall not be allowed to proceed below groundwater.

3.3 FIELD CONTROL

- A. Maintain a careful check to detect any settlement in existing adjacent Work. Notify the Engineer of any signs of settlement. Establish settlement point bench marks and take periodic readings as directed. The Contractor shall take all such precautions and do any and all Work necessary to protect the stability and integrity of adjacent lands, pavements, buildings and utilities from settlement or other movement that may be caused by his dewatering operations. The Contractor shall be solely responsible for any damage or injury to adjacent lands, pavements, buildings, or utilities caused by his dewatering or other operations or his failure to use corrective or preventive procedures or methods.

3.4 DISCHARGE

- A. Dispose of all water removed from the excavation in such a manner as not to endanger public health, property, or any portion of the Work under construction or completed and shall be in accordance with all project permits and the Erosion Prevention and Sediment Control Plans.
- B. Dispose of water in such a manner as to cause no inconvenience to others on or adjacent to the site.
- C. Convey water from the excavation in a closed conduit. Do not use trench excavations as temporary drainage ditches.
- D. Disposal of water shall be approved by the Engineer and shall not cause erosion or sedimentation to occur in existing drainage systems. All sedimentation or blocking of existing systems shall be thoroughly cleaned and returned to original condition by the Contractor, at his expense.
- E. Provide approved sediment traps when water is conveyed into water courses.

3.5 REMOVAL

- A. When system is no longer required, gradually decrease the pumping rate until the water table resumes its natural position so that the velocity of the returning groundwater will be low enough as not to carry fines with it.

- B. When the dewatering system is no longer required and when directed by the Engineer, dismantle and remove the system and all appurtenances from the site.

3.6 CONSTRUCTION DEWATERING

A. Trench Dewatering

1. Before the pipe is lowered into the trench, dewatering may be necessary to visually inspect the trench bottom for the presence of rocks. Trench dewatering may also occur where tie-in welds are necessary, at road-boring sites adjacent to wetlands or water bodies where groundwater has seeped into the trench, locations where set-on weights are placed over the pipe, and in other areas where increased visibility or physical access to the trench is needed. Dewatering pumps and equipment placement are shown on Drawings ANGP-T-G-016 & ANGP-T-G-017. Dewatering will be performed in accordance with applicable appropriation and discharge permits, but at a minimum, will comply with the following procedures:
2. The trench will be dewatered into a well-vegetated upland area with an appropriate energy-dissipation device. Whenever possible, the slope at the point of discharge will be away from any streams or wetlands.
3. If the flow of a discharge cannot be kept out of streams, wetland, drainage ditches, etc., the discharge shall be filtered by one of the methods described below. Dewatering discharge will be directed into a sediment filter bag or a straw bale/silt fence dewatering structure which discharges into a vegetated area to prevent heavily silt-laden water from flowing into wetlands and waterbodies.
4. Only non-woven fabric filter bags will be used for dewatering.
5. Filter bags and dewatering structures must be maintained in a functional condition throughout dewatering activity (e.g., clogged or ripped bags must be replaced) and will be attended at all times during active pumping. Accumulated sediment from the filter bags shall be spread in an approved upland location.
6. The Contractor will comply with applicable permit requirements, including tracking volumes of water pumped, obtaining water samples (if needed) for testing, and taking necessary measures to meet effluent limitations.
7. The Contractor shall remove all water from the excavation promptly and continuously throughout the progress of the work and shall keep the excavation dry at all times until the work is completed and excavation is backfilled or have sufficient weight to resist uplift pressures. Groundwater levels shall be depressed to a minimum of 2 feet below excavation subgrade. No pipe or structure is to be laid in water and water shall not be allowed to rise on or flow over any pipe or structure until such time as approved by the Engineer.
8. Provide a suitable point of discharge from dewatering operations shall be conveyed in a non erosive manner satisfactory to the Engineer.
9. Precautions shall be taken to protect uncompleted work from flooding during storms or from other causes. All pipe lines or structures not stable against uplift during construction or prior to completion shall be thoroughly braced or otherwise protected.

B. Erosion Control

1. Dewatering of the trench will be conducted in a manner which will prevent soil erosion. Discharge rates will be monitored and regulated to prevent erosion. Energy-dissipation devices (i.e., filter bags or straw bale structures) will be used to prevent sediment discharge into a wetland or waterbody.
2. Contractor shall become familiar w/ VTAOT Specifications, Section 105.22 – Environmental Protection and Section 105.23 – Erosion Prevention & Sediment Control.

END OF SECTION

DRAFT - NOT FOR CONSTRUCTION

SECTION 312333 TRENCHING AND BACKFILLING

PART 1 - GENERAL

1.1 SUMMARY

- A. This Section includes the excavation of trenching, backfilling, compacting, dewatering, excavation support and disposal, as shown on the Contract Drawings, and as herein specified.
- B. The Engineer will determine the suitability of materials that are to be used in the work and should any materials encountered be unsatisfactory for the purpose intended, they shall be removed from the site at the Contractor's expense.

1.2 QUALITY ASSURANCE

- A. Reference Standards:
 - 1. The latest edition of the following standards, as referenced herein, shall be applicable.
 - a. Vermont Agency of Transportation (VTAOT), 2011 Standard Specifications for Construction Book.
 - b. "Standard Specifications for Highway Materials and Methods of Sampling and Testing, American Association of State Highway and Transportation Officials (AASHTO)."
 - c. American Society for Testing and Materials (ASTM).
 - d. National Electric Code(NEC)
 - B. The Contractor shall comply with the requirements for soil erosion and sedimentation control and other requirements of governmental authorities having jurisdiction, including the State.
 - C. The Contractor shall provide and pay for all costs in connection with an approved independent testing facility to determine conformance of soils and aggregate with the specifications, in accordance with Section "Quality Requirements."

1.3 SUBMITTALS

- A. Samples:
 - 1. The Contractor shall furnish representative earth materials to the testing laboratory for analysis and report, as directed by the Engineer, or as outlined in the specifications.
- B. Test Results:
 - 1. The testing laboratory shall submit written reports of all tests, investigations, findings and recommendations to the Contractor and the Engineer.

1.4 PROJECT REQUIREMENTS

- A. Notify the Engineer of any unexpected subsurface condition.
- B. Protect excavations by shoring, bracing, sheet piling, or by other methods, as required to ensure the stability of the excavation. Comply with OSHA requirements.

- C. Underpin or otherwise support structures adjacent to the excavation which may be damaged by the excavation. This includes service lines.
- D. Protection of Existing Utilities:
 - 1. Locate existing underground utilities in areas of work. If utilities are to remain in place, provide adequate means of support and protection during earthwork operations. Comply with OSHA requirements.
 - 2. Coordinate interruption and/or termination of utilities with the utility companies and the Owner.
 - 3. Provide a minimum of forty-eight (48) hours notice to the Owner and receive written notice to proceed before interrupting any utility.
- E. Demolish and completely remove from the site any existing underground utilities designated to be removed, as shown on the Drawings or as specified.
- F. Repair any damaged utilities as acceptable to the Owner, Engineer, and utility company at no additional cost to the Owner.
- G. Contractor shall comply with maintenance and protection requirements as approved by the authority having jurisdiction.
- H. Protection of Persons and Property:
 - 1. Barricade open excavations occurring as part of this work and post with warning signs & lights, if required.
 - 2. Operate warning lights as recommended by authorities having jurisdiction, if required.
 - 3. Protect structures, utilities, pavements, and other facilities from damage caused by settlement, lateral movement, undermining, washout and other hazards created by earthwork operations.
 - 4. Perform excavation within drip-line of trees to remain by hand, and protect the root system from damage or dry-out to the greatest extent possible. Maintain moist conditions for root system and cover exposed roots with burlap. Paint cut roots of 1" diameter and larger with emulsified asphalt tree paint.

PART 2 - PRODUCTS

2.1 MATERIALS

- A. The backfill shall be carried to the upper-level of the trench or subgrade. No stones or blasted ledge exceeding 3 inches in diameter shall be allowable during backfill operations. If native material is unsuitable for backfill, as determined by the Construction Manager, bank run gravel meeting VTAOT Section 704.04 shall be utilized.
- B. Run-of-trench material, meeting the above criteria, shall be considered suitable material and shall be used for trench backfill only after tested in accordance with Section "Quality Requirements" and approved by the Engineer. The Contractor shall pay for all additional testing required to determine the conformance of run-of-trench material, if at any time during the Work this material appears to be in non-conformance in the opinion of the Engineer.

PART 3 - EXECUTION

3.1 PRECONSTRUCTION MATERIAL QUALIFICATION TESTING

A. General:

1. Sufficient size samples shall be obtained from the potential borrow source to allow completion of tests listed in paragraph B below. Samples may be obtained from test borings, test pits, or from borrow pit faces provided that surficial dry or wet soil is removed to expose undisturbed earth. Tests listed below shall be performed on each sample obtained. A minimum of three (3) representative samples from each potential borrow source shall be furnished to the testing laboratory for prequalification testing. Test data shall be provided to the Engineer a minimum of 2 weeks prior to construction for approval of borrow source. Three test reports completed within three months prior to construction may be submitted for commercial earth borrow sources or suppliers of stone products (crushed stone or graded stone products) in lieu of prequalification tests as approved by the Engineer.

B. Material Tests:

1. Particle Size Analysis:

- a. Method: ASTM D422
- b. Number of Tests: One (1) per sample; three (3) per potential source.
- c. Acceptance Criteria: Gradation within specified limits.

2. Maximum Density Determination:

- a. Method: ASTM D1557 - Modified Proctor
- b. Number of Tests: One (1) per sample; three (3) per potential source.

3. Re-establish gradation and maximum density of fill material if source is changed during construction.

3.2 PREPARATION

- A. Establish required lines, levels, contours and datum.
- B. Maintain benchmarks and other elevation control points; re-establish if disturbed or destroyed, at no additional cost to the Owner.
- C. Establish location and extent of existing utilities prior to commencement of excavation.

3.3 EXCAVATION

- A. All excavation shall be made to such depth as required and of the width shown on the Contract Drawings to provide suitable room for building the structures and laying the pipe(s) they are to contain and for sheeting, shoring, pumping and draining as necessary, and for removing peat, silt, or any other materials which the Engineer may deem unsuitable. Hand trench excavation may be required to protect existing utilities and structures.
- B. Trench excavation for pipes shall be made by open cut to accommodate the pipe or structure at the depths indicated on the Contract Drawings. Excavation shall be made to such a depth and to the width indicated on the Contract Drawings so as to allow a minimum of six (6) inches of pipe zone

bedding in earth (9 inches in ledge) to be placed beneath the bottom of all structures and barrels, bells or couplings of all pipes installed unless otherwise specified on the drawings.

- C. The bottom of the trench shall be accurately graded to provide a uniform layer of bedding material, as required, for each section of pipe. Trim and shape trench bottoms and leave free of irregularities, lumps, and projections.
- D. Stockpile excavated subsoil for reuse where directed or approved.
- E. Over excavation/under cut: If, in the opinion of the Engineer, existing material below the trench grade is unsuitable for properly placing bedding material and laying pipe, the Contractor shall excavate and remove the unsuitable material and replace the same with an approved pipe zone bedding material properly compacted.
- F. Stability of Excavation: Slope sides of excavations shall comply with local codes and ordinances having jurisdiction. Shore and brace where sloping is not possible because of space restrictions or stability of material excavated. Maintain sides and slopes of excavation in safe condition until completion of backfilling.
- G. Removal of materials beyond the indicated subgrade elevations, without authorization by the Engineer, shall be classified as unauthorized excavation and shall be performed at no additional cost to the Owner.
- H. MUCK EXCAVATION (SEE VTAOT Section 203.05)

3.4 BEDDING AND BACKFILLING

- A. All pipe trenches backfill (pipe zone bedding, pipe zone backfill and trench backfill) shall be compacted by tamping or rolling to achieve a minimum dry density of 90 percent of the modified Proctor maximum dry density of the material used (ASTM D1557). Backfill in pipe trenches to be covered with pavement or in roadways shall be compacted to a minimum of 95 percent of modified Proctor maximum dry density. Backfill materials shall be placed with water content within plus or minus three (3) percent of optimum moisture content per the modified Proctor method (ASTM D1557). Any water used for compaction shall be provided by the Contractor at his own expense. The Contractor is responsible for the repair of any trench settlement at no expense to the owner.
- B. Bedding and backfilling shall be accomplished in three stages unless otherwise specified on the Contract Drawings. The first stage shall involve placement of "pipe zone bedding" as a layer(s) of selected material required to support, or to stabilize unsound or unsatisfactory foundation conditions. The second stage shall involve placement of "pipe zone backfill" from the top of the bedding material up to one (1) foot above the pipe. The third stage involves the placement of "trench backfill" in the remainder of the trench up to the surface of the ground or the bottom of any special surface treatment subgrade elevation.

The bedding material shall be placed in the trench after the trench has been excavated a minimum of six (6) inches in earth (9 inches in ledge) below the bell of the pipe to permit the placing of not less than six (6) inches in earth (9 inches in ledge) of bedding material unless otherwise specified on the Contract Drawings. Where, in the opinion of the Engineer, if more bedding material is required, the excavation shall be performed and bedding placed to the depth ordered by the Engineer.

- D. Provide uniform bearing and support for each section of pipe at every point along the entire length, except where necessary to excavate for bell holes, pipe joints, or other required connections. Dig bell holes and depressions for joints after trench bottom has been graded. Dig no deeper, longer, or wider than needed to make the joint connection properly.

- E. The bedding material shall be placed to the full width of trench. The bedding material shall be placed in loose lifts not exceeding twelve (12) inches to the elevation shown on the Contract Drawings or directed by the Engineer. The bedding material shall be tamped and compacted to form a firm and even bearing surface.
- F. Pipe zone backfill shall be placed to the elevation shown on the Contract Drawings in loose lifts not-to-exceed twelve (12) inches in thickness, before compaction. The backfill shall be placed on both sides of the pipe at the same time and to approximately the same elevation. Any pipe that is damaged or moved out of alignment, regardless of cause, shall be replaced or realigned at the Contractor's expense. Each layer shall be thoroughly compacted by hand-tamping or mechanical means being careful not to damage the pipe. When the pipe zone backfill reaches one (1) foot over the top of the pipe, the entire surface shall be compacted by mechanical means.
- G. The remainder, if any, of the trench above the pipe zone backfill shall be backfilled with suitable material in loose lifts not exceeding twelve(12) inches in thickness before compaction. Each layer shall be thoroughly compacted by mechanical means.

3.5 BACKFILLING AROUND STRUCTURES

- A. The Contractor shall not place backfill against any structure without obtaining the approval of the Engineer. No dumping shall be allowed where materials would flow against or around such structures. Backfill material shall be deposited in horizontal layers not exceeding 6 inches in loose thickness or as shown on the Contract Drawings and thoroughly compacted by hand or by mechanical means to the satisfaction of the Engineer.

3.6 SUSPENSION OF WORK

- A. Whenever the work is suspended, excavations shall be protected and the roadways, if any, left unobstructed. Within or adjacent to private property, material shall be stored at such locations as will not unduly interfere with traffic of any nature and in no case shall materials be stored in locations which will cause damage to existing improvements.

3.7 DISPOSAL OF MATERIAL

- A. Excess and unsuitable materials shall be disposed of by the Contractor on the site in an area approved by the Engineer or legally disposed of off- site at the Contractors expense.

3.8 FIELD QUALITY CONTROL

- A. Notify the Engineer at least three (3) working days in advance of all phases of filling and backfilling operations.
- B. In-place density testing shall be performed to ascertain the compacted density of the fill and backfill materials in accordance with the following methods:
 - 1. In-place relative density:
 - a. Method: AASHTO T238, Nuclear Method
- C. Perform initial density testing to verify that contractors proposed compaction effort will obtain the minimum required densities.
- D. In-place density tests on trench backfills shall be provided for every 500 cubic yards of fill and in vertical lifts not exceeding two (2) feet, and at least once daily.

- E. One particle size analysis (ASTM D422) and one modified Proctor compaction test (ASTM D1557) shall be completed for every 5,000 cubic yards of material placed.
- F. The Engineer may direct additional tests to establish gradation, maximum density, and in-place density as required by working conditions, at the Contractor's expense.
- G. Acceptance Criteria: The criteria for acceptability of in-place fill shall be in-situ dry density and moisture content. If a test fails to qualify, the fill shall be further compacted and re-tested. Subsequent test failures shall be followed by removal and replacement of the material.

END OF SECTION

DRAFT - NOT FOR CONSTRUCTION

SECTION 312500 EROSION AND SEDIMENT CONTROL

PART 1 - GENERAL

1.1 SUMMARY

- A. This Section covers work necessary for stabilization of soil to prevent erosion and sedimentation during and after construction and land disturbing activities. The work shall include the furnishing of all labor, materials, tools, and equipment to perform the work and services necessary as herein specified and as indicated on the Drawings. This shall include installation, maintenance, and final removal of all temporary soil erosion and sediment control measures. All erosion and sediment control methods and devices used shall conform to the latest requirements imposed by federal, state and local authorities.
- B. Comply with applicable project permit applications [Permits Pending] for stormwater discharges from construction activities.
- C. The minimum areas requiring soil erosion and sediment control measures are indicated on the Drawings. The right is reserved to modify the use, location, and quantities of soil erosion and sediment control measures based on activities of the Contractor and as the Engineer considers to be the best interest of the Owner.
- D. The Contractor shall be responsible for repair of any damage caused and shall be financially responsible for any penalties imposed.

1.2 QUALITY ASSURANCE

- A. Soil erosion and sediment control measures shall be implemented in accordance with the requirements and procedures outlined in this specification, contract Drawings and documents, state standards or guidelines for soil erosion and sediment control, and all regulatory authorities having jurisdiction. Where conflicts between requirements exist, the more restrictive rules shall govern.
- B. The Contractor shall provide all temporary control measures shown on the Drawings, or as directed by the Owner, Owner's representative, or soil conservation district for the duration of the contract. Erosion and sediment control Drawings are intended to be a guide to address the stages of work shown. Additional measures not specified on the Drawings may be necessary and shall be implemented to address intermediary stages of work and any conditions that may develop during construction at no cost to the Owner.
- C. Temporary control provisions shall be coordinated with permanent erosion control features to the extent practical to assure economical, effective and continuous erosion and sediment control throughout the construction and post-construction period.
- D. Soil erosion and sediment control measures shall at all times be satisfactory to the Owner's Representative. Owner's Representative will inform the Contractor of unsatisfactory construction procedures and operations if observed. If the unsatisfactory construction procedures and operations are not responded to and corrected within 48 hours, the Owner's Representative may suspend the performance of any or all other construction until the unsatisfactory condition has been corrected. Such suspension shall not be the basis of any claim by the Contractor for additional compensation nor for an extension of time to complete the work. Any complaints, fines, etc. relating to ineffective erosion control, shall be the sole responsibility of the Contractor.

- E. The Contractor shall inspect all soil erosion and sediment control measures at least at the beginning and end of each day to ascertain that all devices are functioning properly during construction. Maintenance of all soil erosion and sediment control measures on the project site shall be the responsibility of the Contractor until final stabilization is complete, and until the permanent soil erosion controls are established and in proper working condition.
- F. The Contractor shall protect adjacent properties and watercourses from soil erosion and sediment damage throughout construction.

1.3 GENERAL

- A. Soil erosion stabilization and sediment control measures consist of the following elements:
 - 1. Maintenance of existing permanent or temporary storm drainage piping and channel systems, as necessary.
 - 2. Installation and maintenance of stabilized construction entrance(s)
 - 3. Construction of new permanent and temporary storm drainage piping and channel systems, as necessary.
 - 4. Construction of temporary erosion control facilities such as silt fences, check dams, etc.
 - 5. Topsoil and Seeding: Placement and maintenance of Temporary Seeding on all areas disturbed by construction. Placement of permanent topsoil, fertilizer, and seed, etc., in all areas not occupied by structures or pavement, unless shown otherwise.
 - 6. Soil Stabilization Seeding: Placement of fertilizer and seed, etc., in areas as Specified hereinafter.
- B. The Contractor shall be responsible for phasing Work in areas allocated for his exclusive use during this Project, including any proposed stockpile areas, to restrict sediment transport. This will include installation of any temporary erosion control devices, ditches, or other facilities.
- C. The areas set aside for the Contractor's use during the Project may be temporarily developed to provide satisfactory working, staging, and administrative areas for his exclusive use. Preparation of these areas shall be in accordance with other requirements contained within these Specifications and shall be done in a manner to both control all sediment transport away from the area.
- D. Stockpiles remaining in place longer than the durations detailed in the project permits shall be considered permanent stockpiles for purposes of erosion and sediment control.
- E. All permanent stockpiles shall be seeded with soil stabilization seed and protected by construction of silt fences completely surrounding stockpiles and located within 10 feet of the toes of the stockpile slopes.
- F. Sediment transport and erosion from working stockpiles shall be controlled and restricted from moving beyond the immediate stockpile area by construction of temporary toe-of-slope ditches and accompanying silt fences as necessary. The Contractor shall keep these temporary facilities in operational condition by regular cleaning, re-grading, and maintenance.
- G. The Contractor shall maintain all elements of the Soil Erosion Stabilization and Sedimentation Control systems and facilities to be constructed during this Project for the duration of his activities on this Project.

- H. Formal inspections made jointly by the Contractor and the Engineer shall be conducted every 2 weeks to evaluate the Contractor's conformance to the requirements of these Specifications, unless more frequent inspections are required by applicable permits.
- I. Replacement or repair of failed or overloaded silt fences, check dams, or other temporary erosion control devices shall be accomplished by the Contractor within 24 hours after receiving written notice from the Engineer.
- J. If the Contractor has not complied with any of the above maintenance efforts to the satisfaction of the Engineer within 2 working days after receiving written notification from the Engineer, the Owner shall have the prerogative of engaging others to perform any needed maintenance or cleanup, including removal of accumulated sediment at constructed erosion control facilities, and deduct from the Contractor's monthly partial payment the costs for such efforts in accordance with the General Condition of the Contract.

1.4 SUBMITTALS

- A. Submittals shall be made in accordance with Section "Submittal Procedures"
- B. Material Certificates signed by material producer and Contractor, certifying that each material item complies with or exceeds specified requirements.
- C. Results of all tests and investigations, including recommendations.
- D. Submit product data, samples, specifications and manufacturer's installation procedures for approval as directed by Engineer prior to use.

PART 2 - PRODUCTS

2.1 GENERAL

- A. Contractor shall provide all materials necessary to perform the work in accordance with the Project Manual, Permits Applications and Permits, or as shown/specified on the Drawings.

PART 3 - EXECUTION

3.1 GENERAL

- A. The Contractor shall comply with and implement all necessary measures as indicated on the project plans and provided in the contract documents.
- B. Review the soil erosion and sediment control Drawings as they apply to current conditions. Any deviation from the Drawings must be submitted for approval to the site Engineer in writing at least 72 hours prior to commencing that work.
- C. Initial soil sediment and erosion control devices shall be in place prior to any land disturbing activity, in their proper sequence, and maintained until permanent protection is established.
- D. The limit of the area of any earthwork operations in progress shall be commensurate with the Contractor's capability and progress in keeping the finished grading, mulching, seeding, and other such permanent control measures current and in accordance with the accepted schedule for construction phasing. Should seasonal limitations make such coordination unrealistic, as

determined by the Owner's Representative, temporary erosion control measures shall be provided immediately by the Contractor at no expense of the Owner.

- E. Temporary erosion control measures shall be used to correct conditions which develop during construction that are needed prior to installation of permanent control features, or that are temporarily needed to control erosion that develops during normal construction practices, but are not associated with permanent control features on the project.
- F. The Contractor shall incorporate all permanent erosion control features (stabilization) into the project at the earliest practical time to minimize the need for temporary controls.
- G. A stabilized construction exit (SCE) shall be installed and maintained at any point where construction vehicles enter a public right-to-way, street or parking area. The SCE shall be used to eliminate mud from the construction area onto public right-of-way. The SCE shall be constructed as shown on the Drawings. Any mud or debris tracked on streets shall be cleaned up immediately.
- H. Dust Control: The Contractor shall provide a commercial grade, enclosed broom mechanical street sweeper to control sediment and/or dust that is tracked on to the adjacent streets. The street sweeper shall be equipped with a water storage tank to wet the area prior to sweeping. Where on site controls do not prevent material from being tracked on to adjacent streets, the street sweeper shall be used to clean the adjacent streets immediately. In addition, at a minimum, the adjacent streets shall be swept at the end of each week or as directed by the Engineer.
- I. Any disturbed or stockpiled areas that will be left exposed more than the days required by the project Permits shall immediately receive temporary or permanent seeding. Mulch/straw shall be used if the season prevents the establishment of a temporary cover. Disturbed areas shall be limed and fertilized prior to temporary seeding.
- J. Permanent vegetation shall be established as specified on all exposed areas according to project permits after final grading. Mulch as necessary for seed protection and establishment. Lime and fertilize seedbed prior to permanent seeding.
- K. Slopes shall be permanently seeded and mulched. Any slopes that erode easily shall be temporarily seeded and mulched. Any slopes deeper than 3:1 or steeper or as indicated on Drawings shall be protected with Erosion Control Blanket per specifications.
- L. All storm drainage outlets must be stabilized, as specified, before the discharge points become operational. Equip all inlets with inlet protection immediately upon construction.
- M. Discharge from dewatering operations for the excavated areas shall not be directed to surface waters without first properly removing the suspended sediment through filtration and/or settlement. The Contractor shall obtain any required permits associated with dewatering activities.
- N. Silt fence shall be installed at locations on the Drawings and any additional locations necessary for proper sediment control. The Contractor shall maintain the silt fence until the project is stabilized and shall remove and dispose of the silt fence and silt accumulation when 1/3 the height of the fence is reached.
- O. Soil erosion and sediment control shall include but not be limited to the approved measures. The Contractor shall be responsible for providing all additional measures that may be necessary to accomplish the intent of the Drawings.
- P. Comply with all other requirements of authorities having jurisdiction.

- Q. Soil Stabilization and Temporary Seeding, except in wetland areas:
1. Soil stabilization seeding shall consist of the application of the following materials in quantities as further described herein for stockpiles and disturbed areas left inactive for more than the number of days defined by the project permits.
 - a. Lime.
 - b. Fertilizer.
 - c. Seed.
 - d. Mulch.
 - e. Maintenance.
 2. Hydroseeding will be permitted as an alternative method of applying seed and associated soil conditioning agents described above. Should the Contractor elect to apply soil stabilization seeding by hydroseeding methods, he shall submit his operational plan and methods to the Engineer.
 3. Temporary Seeding is to be placed and maintained over all disturbed areas prior to Permanent Seeding. Maintain Temporary Seeding until such time as areas are approved for Permanent Seeding. As a minimum, maintenance shall include the following:
 - a. Fix-up and reseedling of bare areas or re-disturbed areas.
 - b. Mowing for stands of grass or weeds exceeding 6 inches in height.

END OF SECTION

SECTION 313710 STONE FILL

PART 1 - GENERAL

1.1 SUMMARY

- A. This section includes provisions for the placement of stone fill or riprap on embankment slopes, drainage courses, culvert inlets and outlets, and streambanks.

1.2 REFERENCES

- A. 2011 Standard Specifications for Construction – Vermont Agency of Transportation
- B. “Standard Specifications for Highway Materials and Methods of Sampling and Testing, American Association of State Highway and Transportation Officials (AASHTO).”

1.3 SUBMITTALS

- A. Material Certificates signed by material producer and Contractor, certifying that each material item complies with or exceeds specified requirements.
- B. Results of all tests, investigations, including recommendations.
- C. Manufacturer’s catalog cuts, production data, and recommended installation procedures for geotextile fabric.

PART 2 - PRODUCTS

2.1 MATERIALS

- A. Stone fill shall conform with VTrans Section 706.04.
- B. Riprap shall conform with VTrans Section 706.03
- C. Bedding shall conform with VTrans Section 704.17A Geotextile: Shall conform to the requirements of Section “Geotextiles”.

PART 3 - EXECUTION

3.1 SURFACE PREPARATION

- A. Clear the surface on which the rip-rap is to be placed of brush, trees, or other objectionable material.

3.2 INSTALLATION

- A. Geotextile Fabric: Shall be installed in conformance with the requirements of Section “Geotextiles.”
- B. Bedding
 - 1. Place the bedding material on the geotextile to the full thickness, six (6) inch minimum, in one operation using methods that will not cause segregation of the aggregate.

2. Prevent contamination of bedding material by natural soils or other materials. Remove bedding materials that become contaminated and replace with uncontaminated bedding material.
3. Do not drop bedding material onto the geotextile from a height exceeding three (3) feet.

C. Stone Fill and Riprap

1. Place the stones so that the dimension approximately equal to the layer thickness is perpendicular to the slope surface such that the weight of the stone is carried by the underlying material, not by the adjacent stones.
2. Place stone fill to minimize void spaces between adjacent stones.
3. On slopes the largest stones shall be placed at the bottom of the slope.
4. Place stone fill to avoid disruption and damage to the bedding material.

END OF SECTION

DRAFT - NOT FOR CONSTRUCTION

SECTION 315000 EXCAVATION SUPPORT AND PROTECTION

PART 1 - GENERAL

1.1 SUMMARY

- A. This Section includes, but is not limited to, the following:
 - 1. Shoring and bracing necessary to protect existing buildings, streets, walkways, utilities, and other improvements and excavation against loss of ground or caving embankments.
 - 2. Maintenance of shoring and bracing.
 - 3. Removal of shoring and bracing, as required.
- B. The purpose of this work is to insure the safety of workmen and the public exposed to the hazard of falling or sliding material. It shall be the Contractor's responsibility to provide protection adequate for this purpose. Details of this sheeting must conform with the requirements of Title 29 Code of Federal Regulations, Part 1926, Safety and Health Regulations for Construction (OSHA). Contractor shall refer to Contract Plans Section 248 Stormwater Technical Memorandum, Attachment 1, Erosion Prevention and Sediment Control Plans, Sheet No. ANGP-T-G-015, "Typical Trench Detail". The Engineer shall reserve the right to increase the minimum requirements set forth therein, depending on the hazard.

1.2 PERFORMANCE REQUIREMENTS

- A. Design, furnish, install, monitor, and maintain excavation support and protection system capable of supporting excavation sidewalls and of resisting soil and hydrostatic pressure and superimposed and construction loads.
 - 1. Delegated Design: Design excavation support and protection system, including comprehensive engineering analysis by a qualified professional engineer, using performance requirements and design criteria indicated.
 - 2. Prevent surface water from entering excavations by grading, dikes, or other means.
 - 3. Install excavation support and protection systems without damaging existing buildings, structures, and site improvements adjacent to excavation.
 - 4. Monitor vibrations, settlements, and movements.

1.3 SUBMITTALS

- A. Delegated-Design Submittal: For excavation support and protection system indicated to comply with performance requirements and design criteria, including analysis data signed and sealed by the qualified professional engineer responsible for their preparation.
- B. Layout drawings for excavation support system and other data prepared by, or under the supervision of, a qualified professional engineer.
- C. System design and calculations must be acceptable to local authorities having jurisdiction.

1.4 QUALITY ASSURANCE

- A. Engineer Qualifications: A professional engineer legally authorized to practice in jurisdiction where Project is located, and experienced in providing successful engineering services for excavation support systems similar in extent required for this Project.
- B. Regulations: Comply with codes and ordinances of governing authorities having jurisdiction.

1.5 PROJECT CONDITIONS

- A. Project-Site Information: A geotechnical report has been prepared for this Project and is available for information only. The opinions expressed in this report are those of geotechnical engineer and represent interpretations of subsoil conditions, tests, and results of analyses conducted by geotechnical engineer. Owner will not be responsible for interpretations or conclusions drawn from the data
 - 1. Make additional test borings and conduct other exploratory operations necessary for excavation support and protection.
 - 2. The geotechnical report is included elsewhere in the Project Manual.
- B. Before starting work, verify governing dimensions and elevations. Verify condition of adjoining properties. Take photographs or video tape to record any existing settlement or cracking of structures, pavements, and other improvements. Prepare a list of such damages, verified by dated photographs or video tape, and signed by Contractor and others conducting investigation.
- C. During excavation, resurvey benchmarks weekly, maintaining accurate log of surveyed elevations for comparison with original elevations. Promptly notify Engineer if changes in elevations occur or if cracks, sags, or other damage is evident.
- D. Survey Work: Engage a qualified land surveyor or professional engineer to survey adjacent existing buildings, structures, and site improvements; establish exact elevations at fixed points to act as benchmarks. Clearly identify benchmarks and record existing elevations.
 - 1. During installation of excavation support and protection systems, regularly resurvey benchmarks, maintaining an accurate log of surveyed elevations and positions for comparison with original elevations and positions. Promptly notify Engineer if changes in elevations or positions occur or if cracks, sags, or other damage is evident in adjacent construction.

1.6 EXISTING UTILITIES

- A. Protect all existing active utility services and structures.
- B. Notify municipal agencies and service utility companies having jurisdiction. Comply with requirements of governing authorities and agencies for protection, relocation, removal, and discontinuing of services.
- C. Interruption of Existing Utilities: Do not interrupt any utility serving facilities occupied by Owner or others unless permitted under the following conditions and then only after arranging to provide temporary utility according to requirements indicated:
 - 1. Notify Construction Manager no fewer than two days in advance of proposed interruption of utility.

2. Do not proceed with interruption of utility without Construction Manager's written permission

PART 2 - PRODUCTS (Not Used)

PART 3 - EXECUTION

3.1 GENERAL

- A. In general, this item will be required wherever an excavation exceeds five feet in depth and the side slopes are not laid back to a safe gradient as set forth in Title 29 Code of Federal Requirements, Part 1926, Safety and Health Regulations for Construction (OSHA).
- B. Wherever shoring is required, locate the system to clear permanent construction and to permit forming and finishing of concrete surfaces. Provide shoring system adequately anchored and braced to resist earth and hydrostatic pressures.

3.2 REMOVAL AND REPAIRS

- A. Remove excavation support and protection systems when construction has progressed sufficiently to support excavation and bear soil and hydrostatic pressures. Remove in stages to avoid disturbing underlying soils or damaging structures, pavements, facilities, and utilities.
 1. Remove excavation support and protection systems to a minimum depth of 48 inches below overlaying construction and abandon remainder. Contract Plans Section 248 Stormwater Technical Memorandum, Attachment 1, Erosion Prevention and Sediment Control Plans, Sheet No. ANGP-T-G-015, "Typical Trench Detail".
 2. Fill voids immediately with approved backfill compacted to density specified in Section "Earth Moving" or "Trenching and Backfilling".
 3. Repair or replace, as approved by Engineer adjacent work damaged or displaced by removing excavation support and protection systems.
 4. Leave excavation support and protection systems permanently in place.

END OF SECTION

SECTION 321116 SUBBASE COURSES

PART 1 - GENERAL

1.1 SUMMARY

- A. This work shall consist of furnishing and placing one or more courses of approved gravel, crushed gravel, dense graded crushed stone, or other proportioned material on a prepared surface or at other locations.
- B. Proof rolling of subgrade for walks and pavements is included in this Section.
- C. Replacement of unsuitable subgrade materials is included in another Section.
- D. Final grading of pavement subbase is specified in this Section.
- E. Stabilization fabric is included in another Section.

1.2 REFERENCES

- A. VTAOT Section 301 - Subbase
- B. "Standard Specifications for Highway Materials and Methods of Sampling and Testing, American Association of State Highway and Transportation Officials (AASHTO)."
- C. "American Society for Testing and Materials (ASTM)."

1.3 SUBMITTALS

- A. Source Quality Control Test Reports: Submit test reports directly to Owner's Representative from the testing agency with copy to Contractor.
- B. Field Testing Reports: Submit results of field testing directly to Engineer with copy to Contractor. Reference testing location to plan, and cross-reference to all retesting required to accept installed subbase material.
 - 1. Note action taken next to all sub-standard test results.

1.4 QUALITY ASSURANCE

- A. Testing Laboratory Qualifications: To qualify for acceptance, the soil testing laboratory must demonstrate to Owner's Representative satisfaction, based on evaluation of laboratory-submitted criteria conforming to ASTM E 699, that it has the experience and capability to conduct the required testing without delaying the progress of the Work.
- B. Field Testing and Inspection Service: Contractor shall retain the services of the same independent soil testing laboratory used for source qualification testing to provide soil testing during pavement subbase installation.

PART 2 - PRODUCTS

2.1 SOURCE QUALIFICATION TESTING

A. Contractor shall employ and pay for a qualified independent soil testing laboratory to perform soil testing services for source qualification.

1. GRAVEL FOR SUBBASE. Gravel for subbase shall consist of material reasonably free from silt, loam, clay, and organic matter. It shall be obtained from approved sources and shall meet the following requirements:

(a) Grading. Gravel for subbase shall meet the gradation requirements of the following table as determined in accordance with AASHTO T 27 and AASHTO T 11:

TABLE 704.04A - GRAVEL FOR SUBBASE

Sieve Designation	Percentage By Mass (Weight) Passing Square Mesh Sieves
4.75 mm (No. 4)	20 to 60
150 μ m (No. 100)	0 to 12
75 μ m (No. 200)	0 to 6

(b) Re-establish subbase material properties if source is changed during construction.

(c) The gravel shall be uniformly graded from coarse to fine. The maximum size stone particles shall not exceed 67 percent of the thickness of the layer being placed.

(d) Percent of Wear. Percent of wear shall not be more than 50 percent when tested in accordance with AASHTO T 96.

2. CRUSHED GRAVEL FOR SUBBASE. Crushed gravel for subbase shall be produced from natural gravels or crushed quarried rock and shall be a material reasonably free from silt, loam, clay, or organic matter. It shall be obtained from approved sources and shall meet the following requirements:

(a) Grading. Crushed gravel for subbase shall be uniformly graded from coarse to fine and shall meet the gradation requirements of the following table as determined in accordance with AASHTO T 27 and AASHTO T 11:

TABLE 704.05A - CRUSHED GRAVEL FOR SUBBASE

Grading	Sieve Designation	Percentage by Mass (Weight) Passing Square Mesh Sieves
Coarse	4 inch	95 to 100
	No. 4	25 to 50
	No. 100	0 to 12
	No. 200	0 to 6
Fine	2 inch	100
	1 1/2 inch	90 to 100
	No. 4	30 to 60
	No. 100	0 to 12
	No. 200	0 to 6

- (b) Percent of Wear. Percent of wear shall not be more than 40 percent when tested in accordance with AASHTO T 96.
 - (c) Fractured Faces. At least 50 percent by mass (weight) of the material coarser than the No. 4 sieve shall have at least one fractured face in accordance with Vermont Standard Test Procedures AOT-MRD 23.
3. DENSE GRADED CRUSHED STONE FOR SUBBASE. Dense graded crushed stone for subbase shall consist of clean, hard, uniformly graded, crushed stone. It shall be sufficiently free from dirt, deleterious material, and pieces that are structurally weak and shall meet the following requirements:
- (a) Source. This material shall be obtained from approved sources. The area from which this material is obtained shall be stripped and cleaned before blasting.
 - (b) Grading. Dense graded crushed stone for subbase shall meet the gradation requirements of the following table as determined in accordance with AASHTO T 27 and AASHTO T 11:

TABLE 704.06A - DENSE GRADED CRUSHED STONE FOR SUBBASE

Sieve Designation	Percentage by Mass (Weight) Passing Square Mesh Sieves
3 1/2 inch	100
3 inch	90 to 100
2 inch	75 to 100
1 inch	50 to 80
1/2 inch	30 to 60
No. 4	15 to 40
No. 200	0 to 6

- (c) Percent of Wear. The percent of wear of the crushed stone shall be not more than 40 percent when tested in accordance with AASHTO T 96. When the aggregate is composed of crushed igneous rock, the percent of wear of the crushed stone shall be not more than 50 percent when tested in accordance with AASHTO T 96.
- (d) Thin and/or Elongated Pieces. Not more than 30 percent by mass (weight) of the material coarser than the No. 4 sieve shall consist of thin and/or elongated pieces in accordance with Vermont Standard Test Procedures AOT-MRD 22.
- (d) Filler. Filler shall be obtained from approved sources and shall consist of clean, hard, uniform graded, crushed stone and/or stone screenings produced by the crushing process. The material shall consist of hard, durable particles sufficiently free from dirt, organic material, structurally weak pieces, and other deleterious materials and shall comply with the requirements of parts (a), (c), and (d) above.

Filler material shall meet the gradation requirements of the following table as determined in accordance with AASHTO T 27 and AASHTO T 11:

TABLE 704.06B - FILLER

Sieve Designation	Percentage by Mass (Weight) Passing Square Mesh Sieves
¾ inch	100
½ inch	70 to 100
No. 4	50 to 90
No. 100	0 to 12
No. 200	0 to 6

4. GRAVEL BACKFILL FOR SLOPE STABILIZATION. Gravel backfill for slope stabilization shall meet the requirements of Subsection 704.04(a).
5. GRANULAR BACKFILL FOR STRUCTURES. Granular backfill for structures shall be obtained from approved sources. It shall consist of satisfactorily graded, free draining granular material reasonably free from loam, silt, clay, and organic material.

Granular backfill for structures shall meet the gradation requirements of the following table as determined in accordance with AASHTO T 27 and AASHTO T 11:

TABLE 704.08A – GRANULAR BACKFILL FOR STRUCTURES

Sieve Designation	Percentage by Mass (Weight) Passing Square Mesh Sieves
3 inch	100
No. 4	45 to 75
No. 100	0 to 12
No. 200	0 to 6

6. BACKFILL FOR MUCK EXCAVATION. Backfill for muck excavation shall consist of granular material or blasted rock broken into various sizes that will form a compact embankment with a minimum of voids.

When granular material is used, it shall meet the requirements of Subsection 703.04.

- B. Pre-Qualified Material Sources: Contractor may submit, in lieu of independent laboratory test results, a copy of recent VTranscertification of proposed source.

1. Engineer may require additional testing by an independent testing laboratory when:
 - a. The latest test for the source is two (2) years old.
 - b. A change in the character of the material occurs.
 - c. The Engineer determines that additional testing is necessary due to the observed properties of the supplied material.

2.2 MATERIALS

- A. Materials shall meet the requirements of the following VTAOT Subsections:

1. Coarse Aggregate for Concrete.....704.02
2. Gravel for Subbase704.04

- 3. Crushed Gravel for Subbase704.05
- 4. Dense Graded Crushed Stone for Subbase704.06

- B. Certifications required shall be submitted in conformance with Subsection 700.02 – Material Certification.
- C. All material shall meet the specified gradation prior to placement. All processing shall be completed at the source.
- D. Stabilization Fabric: Conform to Section “Geotextiles”

PART 3 - EXECUTION

3.1 PREPARATION

- A. Establish required lines, levels, contours, and datum.
- B. Maintain benchmarks and other elevation control points. Re-establish, if disturbed or destroyed, at no additional cost to Owner.
- C. Proof-roll existing subgrade to the satisfaction of the Engineer. Should the subbase course become unstable at any time prior to the placement of the overlying course(s), correct the unstable condition to the satisfaction of the Engineer. Replace unstable or weak subgrade materials with suitable material as provided in the Specifications.
- D. Place stabilization fabric in locations as directed on the plans and in accordance with Section “Geotextiles” after subgrade has been proof-rolled and accepted by the Engineer.

3.2 INSTALLATION

- A. Place subbase material in uniform horizontal layers, with a maximum compacted thickness of 12 inches.
- B. Place subbase in a manner to avoid segregation. Uncontrolled spreading shall not be permitted.
- C. After each layer of subbase material is placed, it shall be graded to obtain a smooth, even surface as specified in VTAOT Subsection 301.05.

3.3 COMPACTION

- A. Following grading operations, the subbase shall be thoroughly compacted as specified in Subsection VTAOT 301.06.
- A. Where subbase courses must be moisture-conditioned before compaction, uniformly apply water to the surface. Prevent free water from appearing on the surface during or subsequent to compaction operations.
- B. Compact all portions of each layer to a density not less than 95 percent of the maximum density.
- C. Final tolerances for the top surface of the subbase course requires that the surface does not extend more than ¼ inch above nor more than ¼ inch below the specified grade at any location.

3.4 TRAFFIC ON SUBBASE

- A. The movement of vehicular traffic over the final surface of the subbase may be permitted at locations designated by, and under such restrictions as ordered by the Engineer, provided such movements take place prior to the final finishing of this course to the specified tolerance. The movement of construction equipment on this course may be permitted, at locations designated by and under such restrictions as ordered by the Engineer at locations where permission is granted for such movement, the temporary surface of the course upon which the construction traffic is running, shall be placed and maintained for at least 2 inches above the final surface of this course. Just prior to paving, and after all construction traffic not required for the removal has ceased, remove the 2 inch protective layer, prepare the exposed surface of the course, and compact to the specified tolerance.
- B. Should the subbase become mixed with the subgrade or any other material, through any cause whatsoever, remove such mixture and replace it with the specified subbase material.

3.5 FIELD QUALITY CONTROL

- A. Notify the Engineer at least one (1) working day in advance of all phases of subbase installation.
- B. Comply with the requirements of this Section for in-place relative density testing.
 - 1. In-place relative density:

Method:	AASHTO T238 Nuclear Method
Number of Tests:	One (1) per specified interval.
Acceptance Criteria:	± Two (2) percent of specified percent compactions.
 - 2. Compaction tests shall be provided for every 1000 SY of subbase placement. A minimum of three for each lift is required.
 - 3. The Engineer may direct additional tests to establish gradation, maximum density, and in-place density as required by working conditions.
 - 4. Acceptance Criteria: The sole criterion for acceptability of in-place subbase shall be in situ dry density. Minimum dry density for all subbase shall be 95 percent of the maximum dry density. If a test fails to qualify, the fill shall be further compacted and re-tested. Subsequent test failures shall be followed by removal and replacement of the material.

END OF SECTION

SECTION 321216 ASPHALT PAVING

PART 1 - GENERAL

1.1 SUMMARY

- A. This section includes provisions for hot-mixed asphalt concrete paving over prepared subbase.
- B. This section includes provisions for replacing pavement removed during the course of the Work, or damaged resulting from Contractor's operations.
- C. This work shall consist of constructing one or more courses of bituminous mixture on a prepared foundation in accordance with these specifications and the specific requirements of the type of surface being placed, and in reasonably close conformity with the lines, grades, thicknesses, and typical cross sections shown on the Plans or established by the Engineer.
- D. This section does not cover porous asphalt in locations defined on the project drawings. Porous asphalt shall meet the "UNHSC Design Specifications for Porous Asphalt Pavement and Infiltration Beds".

1.2 REFERENCES

- A. VTAOT Section 406 – MARSHALL BITUMINOUS CONCRETE PAVEMENT
- B. "Standard Specifications for Highway Materials and Methods of Sampling and Testing, American Association of State Highway and Transportation Officials (AASHTO)."
- C. "American Society For Testing and Materials (ASTM)."

1.3 SUBMITTALS

- A. Material Certificates signed by material producer and Contractor, certifying that each material item complies with or exceeds specified requirements. Materials shall meet the requirements of the following Subsections:
 - 1. Performance-Graded Asphalt Binder 702.02
 - 2. Emulsified Asphalt, RS-1 702.04
 - 3. Aggregate for Marshall Bituminous Concrete Pavement 704.10(a)
- B. Field Test Reports: Submit results of field testing directly to the Engineer.

1.4 SITE CONDITIONS

- A. WEATHER AND SEASONAL LIMITATIONS.
 - 1. The bituminous material shall not be placed when the ambient air temperature and temperature at the paving site in the shade and away from artificial heat is below 40°F for courses 1 ¼ inches or greater in compacted thickness or below 50°F for courses less than 1 ¼ inches in compacted thickness.
 - 2. Bituminous material shall not be placed on a wet or frozen surface or when weather or other conditions would prevent the proper handling, finishing, or compacting of the material, unless otherwise approved by the Engineer.
 - 3. Bituminous material shall not be applied between November 1st and May 1st. Bituminous wearing course materials shall not be applied before May 15th or after October 15th.

4. When it is in the public interest, the Construction Engineer may adjust the ambient air temperature requirements, pavement temperature requirements, or extend the dates of the paving season.
 5. The road surface is sufficiently dry.
 6. Weather conditions or other conditions are favorable and are expected to remain so for the performance of satisfactory work.
- C. Grade Control: Establish and maintain required lines and elevations.
- D. In no instance shall the materials and thicknesses of pavement and subbase courses replaced be less than that removed, unless approved by the Engineer.

1.5 SEQUENCING AND SCHEDULING

- A. Coordinate the placement of asphalt concrete pavement with the completion of underground work by other trades.
- B. VTAOT Section 406.17 - TRAFFIC CONTROL. Whenever traffic must be maintained during a paving operation, uniformed traffic officers and/or flaggers shall be stationed at each end of the section being paved and at such other locations as may be required by the Engineer. The uniformed traffic officers or flaggers shall conform to the requirements of VTAOT Section 630.

Whenever one-way traffic is maintained by the Contractor, the traveling public shall not be delayed more than 10 minutes unless otherwise directed by the Engineer. Two-way traffic shall be maintained during non-working hours.

PART 2 - PRODUCTS

2.1 MATERIALS

- A. Unless otherwise noted on the Drawings, all bituminous concrete pavement shall be designed in conformance with the design criteria for Bituminous Concrete Pavement. Unless otherwise specified for highways, Type I shall be used for base course, Types I or II shall be used for binder course, and Types II, III, or IV shall be used for wearing course. Unless otherwise specified for bridges, Type IV shall be used for binder course. Refer to VTATO Section 406, Table 406.03A – Percentage by Mass Passing Square Mesh Sieve.

PART 3 - EXECUTION

3.1 SURFACE PREPARATION

- A. General: Remove loose material from compacted subbase surface immediately before commencing paving operations.
- B. Proof-roll prepared subbase surface with a ten-ton static, steel-wheel roller to check for unstable areas and areas requiring additional compaction, witnessed by the Engineer at least forty-eight (48) hours prior to scheduled paving operations.
- C. Do not begin paving work until deficient subbase areas have been corrected and are ready to receive paving.

- D. Sawcut edges of existing pavement to achieve straight line transitions between old and new pavement. Make a second sawcut through the top course of existing pavement, 18 inches from the first cut to provide a staggered joint.
- E. Tack Coat: Apply to contact surfaces of previously constructed asphalt or Portland cement concrete and surfaces abutting or projecting into asphalt concrete pavement. Distribute at rate of 0.03 to 0.07 gallons per square yard of surface.
- F. Allow to dry until at proper condition to receive paving.
- G. Exercise care in applying bituminous materials to avoid smearing of adjoining surfaces. Remove and clean damaged surfaces.
- H. Do not commence pavement replacement operations until all buried work beneath pavement repair has been completed to the satisfaction of the Engineer.
- I. Where trench dimensions preclude the use of proof rolling equipment, demonstrate the stability of the subgrade and subbase through other means, as acceptable to the Engineer.

3.2 PLACING AND COMPACTING MIX

- A. General: Place and compact asphalt pavement courses in accordance with VTAOT Section 406 unless otherwise specified.
- B. Place inaccessible and small areas by hand, and compact with hot hand tampers or vibrating plate compactors.
- C. Chamfer edges of walks at 45° angle where walks do not abut curb.
- D. Joints: Make joints between old and new pavements, or between successive days' work, to ensure continuous bond between adjoining work. Construct joints to have same texture, density, and smoothness as other sections of asphalt concrete course. Clean contact surfaces and apply tack coat.
- E. Place tack coat between successive courses if more than forty-eight (48) hours have elapsed after placing the preceding course. Apply tack coat at a rate of 0.03 to 0.07 gallons per square yard of surface.
- F. Compaction: Compact asphalt pavement courses with a static steel wheel roller only, unless otherwise approved by the Engineer, based upon work conditions.
- G. Remove and patch areas of any asphalt concrete course deemed unsatisfactory by the Engineer, at the Contractor's expense. Remove hardened or set asphalt by saw cutting.
- H. Adhere to VTAOT Section 406.14 for compaction requirements. This, however, shall not relieve the Contractor of his responsibility to provide a well densified pavement. It shall be the Contractor's obligation to recognize difficulties in compacting the mix, and to make appropriate corrections.
- I. Roll and compact the asphalt concrete course until the finished surface is free from depressions, waves or other defects that would prevent proper drainage. The finished surface shall be uniform in texture and appearance.
- J. Protection: After final rolling, do not permit vehicular traffic on pavement until it has cooled and hardened. No traffic will be permitted on placed material until the material has been thoroughly compacted and has cooled to 140°F unless otherwise authorized by the Engineer.

- K. Erect barricades to protect paving from traffic until mixture has cooled enough not to become marked.

3.3 FIELD QUALITY CONTROL

- A. General: Testing in-place asphalt concrete courses for compliance with requirements for thickness and surface smoothness will be done by Owner's testing laboratory. Repair or remove and replace unacceptable paving as directed by Engineer.
 - 1. For material with an average density that is less than 90.5% or in excess of 98.5%, the Construction Engineer will evaluate whether the material will be removed and replaced by the Contractor at no expense to the Agency or a greater penalty imposed.
- B. Joints: Shall comply in accordance with VTAOT Section 406.15, Joints between old and new pavements, or between successive day's work, shall have a thorough and continuous bond between the old and new mixtures.
- C. Thickness: In-place compacted thickness tested in accordance with ASTM D 3549 will not be acceptable if exceeding following allowable variations:
 - 1. Base Course: Plus or minus 1/2 inch.
 - 2. Binder and Surface Course: Plus or minus 1/4 inch.
 - 3. Cumulative Thickness Tolerances: Plus or minus 1/4 inch for nominal cumulative thicknesses less than or equal to 4 inches. Plus or minus 1/2 inch for nominal cumulative thicknesses greater than 4 inches.
- D. Surface Smoothness: Contractor shall comply with VTAOT Section 406.16 – Surface Tolerances. Test finished surface of each asphalt concrete course for smoothness, using 10-foot straightedge applied parallel with and at right angles to centerline of paved area. Surfaces will not be acceptable if exceeding the following tolerances for smoothness:
 - 1. Base and Binder Course Surfaces: 1/4 inch.
 - 2. Wearing Course Surface: 3/16 inch.
 - 3. Crowned Surfaces: Test with crowned template centered and at right angle to crown. Maximum allowable variance from template is 1/4 inch.
- E. Check surface areas at intervals as directed by Engineer.
- F. On areas where irregularities or unavoidable obstacles make the use of mechanical spreading and finishing equipment impracticable, the mixture shall be spread, raked, luted, and compacted by hand methods.

END OF SECTION

SECTION 321500 CRUSHED STONE SURFACING

PART 1 - GENERAL

1.1 SUMMARY

- A. This section includes the placement of crushed stone pavement.
- B. Place crushed stone pavement in conformance with the lines, grades, thicknesses and typical sections as shown or detailed on the Drawings.

1.2 REFERENCES

- A. VTAOT Section 401 – Aggregate Surface Courses, This work shall consist of furnishing and placing a wearing course of approved aggregate on a prepared surface.
- B. "Standard Specifications for Highway Materials and Methods of Sampling and Testing, American Association of State Highway and Transportation Officials (AASHTO).
- C. "American Society for Testing and Materials (ASTM)."

1.3 SUBMITTALS

- A. Samples:
 - 1. The Contractor shall furnish earth materials to the testing laboratory for analysis and report, as directed by the Engineer, or as outlined in the specifications VTAOT Section 700.02 – Materials Certification
- B. Test Reports:
 - 1. The testing laboratory shall submit written reports of all tests, investigations, findings, and recommendations to the Contractor and the Engineer.

PART 2 - PRODUCTS

2.1 MATERIALS

- A. Aggregate for Surface Course and Shoulders: Aggregate for surface course and shoulders shall consist of clean, hard gravel, crushed gravel, or crushed stone. It shall be reasonably free from silt, loam, clay, or organic matter. It shall be obtained from approved sources and shall meet the requirements of VTAOT Section 401 and meeting the following gradation requirements VTAOT Section 704.12A – Aggregate for Surface Course and Shoulders:

<u>Sieve</u>	<u>Percent Passing</u>
1-1/2"	100
1"	90 - 100
No. 4	-45 - 65
No. 100	0 - 15
No. 200	0 - 12

- 1. Grading. Aggregate for surface course and shoulders shall be uniformly graded from coarse to fine and shall meet the gradation requirements of the following table as determined in accordance with AASHTO T 27 and AASHTO T 11:

2. Percent of Wear. The percent of wear when tested in accordance with AASHTO T 96 shall be not more than 40 percent for material used as aggregate surface course or not more than 50 percent for material used as aggregate shoulders.
- B. It shall be the Contractor's responsibility to provide a material which meets this specification and is within his capabilities to fine grade to the required tolerances. Should the subbase course become unstable at any time prior to the placement of the overlying course due to the gradation of the material furnished, the Contractor shall, at his own expense, correct the unstable condition to the satisfaction of the Engineer.
- C. All material shall meet the specified gradation prior to placement. All processing shall be completed at the source.

PART 3 - EXECUTION

3.1 PREPARATION

- A. Establish required lines, levels, contours, and datum.
- B. Maintain benchmarks and other elevation control points. Re-establish, if disturbed or destroyed at no additional cost to the Owner.
- C. Place aggregate surface course only after subgrade and subbase has been proof-rolled and approved by the Engineer. Unstable or weak subgrade materials shall be replaced with suitable material at the Contractor's expense.

3.2 PLACING

- A. Place soil stabilization fabric in accordance with VTAOT Section 720 "Stabilization or Geotextile Fabric," if required by the Drawings or otherwise specified.
- B. The maximum layer thickness for placement of any aggregate surface material shall be 6 ± 2 inches after compaction. All layers shall be placed and compacted at approximately equal thickness. In the placement of layers, all joints shall be staggered at least 12 inches.
- C. The aggregate shall be placed and properly shaped using equipment that allows the typical cross-section and design grade to be attained. Should aggregate segregation occur, the Contractor shall remove and replace the segregated material or manipulate it until uniform gradation is obtained.

3.3 COMPACTION

- A. After each layer of surface material is placed, it shall be thoroughly compacted to a uniform density of not less than 95 percent of the maximum dry density determined by AASHTO T 99, Method C. Suitable and effective equipment, meeting the approval of the Engineer, shall be used to obtain a true and even surface during compaction. All holes or depressions found during the compacting shall be filled with additional material, reworked, and compacted. If required, water shall be uniformly applied over the aggregate material during compaction in an amount necessary to produce proper consolidation. The aggregate shall be thoroughly compacted with an approved power roller with a mass (weight) not less than 8 tons, or an approved rubber tired roller, or by other approved methods.

END OF SECTION