

Exhibit VGS-AG-096

**STATE OF VERMONT
PUBLIC UTILITY COMMISSION**

Investigation pursuant to 30 V.S.A. §§ 30 and)	
209 regarding the alleged failure of Vermont)	
Gas Systems, Inc. to comply with the)	Case No. 17-3550-INV
certificate of public good in Docket 7970 by)	
burying the pipeline at less than required)	
depth in New Haven, Vermont)	

Affidavit of Jeffrey A. Nelson

I, Jeffrey A. Nelson, being duly sworn, hereby depose and state as follows:

Background

1. I am the Director of Energy and Environmental Services for the Vermont office of Vanasse Hangen Brustlin, Inc. (“VHB”). I have worked as a consulting hydrologist and hydrogeologist in Vermont since 1982. I have a Bachelor of Science degree in Geology and a Master of Science degree in Civil Engineering, both from the University of Vermont. My educational training includes extensive scientific coursework, with a specialization in surface water hydrology and groundwater hydrogeology. My professional background includes the direction, completion, and presentation of technical studies, evaluation and review of scientific data pertaining to water resources, determination of compliance with various State and Federal regulatory requirements and application for various permits and authorizations. Specific areas of expertise include stormwater treatment and control; erosion prevention and sediment control planning and design; and wetland and stream assessment, impact assessment, restoration and mitigation. I have designed and implemented a large number of projects in Vermont and the northeastern United States involving water resources assessment, planning, impact analysis, permitting and monitoring. I am a Certified Professional in Erosion and Sediment Control and am Certified Professional in Storm Water Quality.

2. In Docket 7970, I prepared testimony and sponsored the Section 248 Natural Resources Report and related impact assessments prepared by VHB in connection with the Vermont Gas Systems, Inc. (“Vermont Gas” or “VGS”) Addison Natural Gas Project (“ANGP” or “Project”).

3. My testimony was included in: Vermont Gas Systems, Inc. Addison Natural Gas Project Certificate of Public Good – Section 248 Petition dated December 20, 2012; the Docket 7970 Vermont Gas Systems, Inc. – Addison Natural Gas Project 2-28-13 Amended and Supplemented Section 248 Filing dated February 28, 2013; and the Public Service Board (“PSB”) Docket 7970, Vermont Gas Systems, Inc. Supplemental and Rebuttal Prefiled Testimony and Exhibits dated June 28, 2013 (“6/28/13 Alignment”). I also provided additional testimony, memoranda and exhibits in five Non-Substantial Change (“NSC”) filings in Docket 7970, to include: NSC 1 submitted on April 3, 2015, NSC 2 submitted on July 9, 2015, NSC 3 submitted on August 25, 2015, NSC 4 submitted on November 5, 2015, and NSC 5 submitted on March 25, 2016.

4. I will refer herein primarily to the 6/28/13 Alignment, as this was the basis for the Certificate of Public Good (“CPG”) issued by the PSB in Docket 7970 on December 23, 2013.

5. VHB was also responsible for the preparation of application materials for the following collateral permits that were required for Project construction or operations. These “Collateral Permits” included:

- Vermont Individual Wetland Permit #2012-184. Issued June 9, 2014 (“VWP”).
- Vermont Individual Stream Alteration Permit #SA-5-9029. Issued June 9, 2014 (“SAP”). (Provided here as Attachment A)
- Vermont Individual Clean Water Act Section 401 Water Quality Certification for ANGP Phase 1. Issued June 9, 2014 (“401 WQC”).
- Vermont Individual Construction Stormwater Discharge Permit #6949-INDC. Issued June 9, 2014 (“INDC”).

- US Army Corps of Engineers Section 404 and Section 10 Permit #NAE-2012-0123. Issued June 23, 2014 (“404”).

6. All of the above Collateral Permits were issued for the Project in 2014.

7. During the course of the PSB Project review process, as a result of stakeholder input and involvement prior to construction as well as further project planning/design, VGS made certain modifications to the Project alignment and design. As necessary, amendments to the Collateral Permits were sought and obtained.

Stream Crossings

8. As presented in the 6/28/13 filing, the Project involved a total of 47 perennial or intermittent stream crossings (Supp. JAN-7, at 5)(Provided here as Attachment B). Of these, 21 occurred at larger streams or rivers with greater than one square mile of upstream drainage area, the jurisdictional threshold at which a Stream Alteration Permit would typically be required by VT DEC pursuant to 10 V.S.A. Chapter 41 (Supp. JAN-7, at 2, Board Finding 368) (Provided here as Attachment B).

9. For these larger streams, DEC also typically defined a “Fluvial Erosion Hazard” or FEH zone, which was intended to represent the potential area of lateral stream channel migration over time (Supp. JAN-7, at 3, Board finding 377) (Provided here as Attachment B). FEH zones for each of the larger streams were delineated by DEC and further refined by VHB in collaboration with the DEC using the Step 1 corridor delineation methodology outlined in the Vermont River Corridor Protection Guide Technical Appendix (DEC, 2008). The delineated FEH Zones associated with the larger streams are shown on the Attachment to Supp. JAN-7.

10. To protect existing and designated uses pursuant to the Vermont Water Quality Standards (ANR, 2011) associated with these jurisdictional streams, a tiered approach to stream crossing design was undertaken. First, for all river crossings, and where feasible for larger

streams, installation of the transmission line was proposed to occur using Horizontal Directional Drilling (“HDD”). A typical detail depicting how and where HDD would be used was prepared by CHA (See Supp. JAN-9, Attachment 1, Drawing ANGP-T-G-020, Detail 5) (Provided here as Attachment C).

11. Second, where HDD was determined not to be feasible, open trench excavation would be used for crossing these larger streams. A typical detail depicting how and where open trenching would be used was prepared by CHA (See Supp. JAN-9, Attachment 1, Drawing ANGP-T-G-020, Detail 6) (Provided here as Attachment C). It should be noted that two additional crossing locations, along the built portion of the Chittenden County Circumferential Highway (VT Route 289), were designed over existing culverted segments of Alder Brook and are not included in Detail 6 or the Stream Alteration Permit. These two crossings were not subject to SAP jurisdiction as they did not involve any proposed modification of the stream channel or FEH zone.

Depth of Cover at Stream Crossings

12. Within these two construction details (5 and 6 above), specific practices were described for the subject crossing locations to avoid or minimize impacts at the specified stream or river crossing locations. These measures included, for example, a proposed minimum vertical separation of seven feet between the channel bottom and the top of the pipeline (Note 4), and a top of pipe elevation equal to or deeper than the channel bottom throughout the entire FEH zone (Note 2). These criteria were proposed by VGS to prevent exposure of the transmission line over time due to either vertical downcutting of the stream channel or horizontal channel movement within the FEH zone.

13. The stream crossing locations of the HDD and open trench crossings indicated in Details 5 and 6 are indicated by Mile Post “MP” distance along the transmission line. These represent the entirety of the stream crossing locations that were jurisdictional under the SAP requirements, and at which these details were intended to be applicable to Project construction activities.

14. Construction Type 7 also depicts a typical open trench stream crossing (See Supp. JAN-9, Attachment 1, Drawing ANGP-T-G-006) (Provided here as Attachment D). Construction Type 7 is called out at the specified MP locations of non-HDD stream crossings including the stream crossings specified Drawing ANGP-T-G-020, Detail 6. (See Supp. JAN-9, Attachment 1, Drawings ANGP-T-C-001 through ANGP-T-C-085).

15. At the time of the 6/28/13 filing, no specific minimum depth of cover representation was presented to the PSB for streams with upstream drainage areas of less than one square mile not jurisdictional under DEC stream alteration review (“smaller streams” or “non-jurisdictional streams”). Likewise, in the materials submitted to ANR in support of applications for the Collateral Permits, no minimum depth criterion was proposed or required for the smaller streams.

16. The transmission line crossings of smaller streams, which are not jurisdictional under the DEC stream alteration program, pose a considerably lower likelihood of either vertical channel downcutting or horizontal movement of the stream channel over time, given the lesser flows, velocities and stream energy associated with these features. Therefore, these features correspondingly present a much lesser risk of the transmission line becoming exposed over time.

17. However, a discrepancy in the 6/28/13 EPSC plans is noted, in that Construction Type 7 depicts 84” minimum cover at stream crossing locations where Type 7 is indicated on the

EPSC plans. These crossing locations included certain smaller non-jurisdictional streams, which is incorrect.

18. The actual intended depth of cover for the smaller stream locations was not clearly identified in the 6/28/13 plan set.

Final Design Alignment and Depth of Cover Requirements

19. The Amendment to the SAP No. SA-5-9029 issued January 15, 2016 permits 19 jurisdictional stream crossings on the ANGP Transmission mainline as shown in the December 15, 2015 ANGP EPSC Plan Set. The permitted crossings include 10 stream locations to be crossed by HDD and 9 to be crossed by open trench. The depths for each stream crossing are included in the HDD Stream Crossing – Typical Section detail (Detail 4) and the Open Trench Stream Crossing – Typical Section detail (Detail 8) included on Sheet ANGP-T-G-017 (Provided here as Attachment E).

20. Ultimately, to provide clarity to the construction contractor regarding the original intent of the design, project engineering firm CHA included a Table on the updated EPSC Plan Set included in the NSC 3 filing with the PSB on August 25, 2015 (See Drawing ANGP-T-G-015, Detail 7) (Provided here as Attachment F). This detail specified a 5-foot depth of cover unless otherwise noted by the two details that I describe above which are applicable to the specified list of jurisdictional streams/rivers.

Conclusions

21. Depth of cover requirements for larger SAP jurisdictional streams are specified at a minimum of seven feet consistently through the project record to include Docket 7970 application materials, issued CPG, and non-substantial change filings as well as the issued Stream Alteration Permit and application materials.

22. The final ANGP alignment, as depicted on the December 2015 plan Sheet ANGP-T-G-017 included in the Stream Alteration Permit No. SA-5-9029 amendment request for the SAP Amendment issued January 15, 2016 includes 19 SAP jurisdictional stream crossings, ten to be constructed by HDD and nine by open trench, with minimum depth requirements of seven feet under the stream channel and equal to the bottom channel elevation throughout the FEH zone. These depth criteria are protective of the stream, stream corridor and transmission line over time due to either vertical downcutting of the stream channel or horizontal channel movement within the FEH zone.

23. The ANR did not review or specify depth of cover for the smaller streams on the project. The depth of cover for smaller streams was not specified by VGS in Docket 7970 prior to the August 25, 2015 NSC 3 filing. This filing clarified that, unless otherwise specified, the depth of cover requirements for a stream crossing is five feet.

24. The 5-foot depth of cover for the smaller streams, compared to the depth requirements for the larger streams, is appropriate and protective, given the limited potential for stream channel downcutting or lateral migration associated with these features.

Dated at Burlington, Vermont this 4th day of August, 2017.

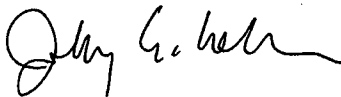

Jeffrey A. Nelson

Subscribed and sworn to before me this 4th day of August, 2017.

Digitally signed with approval from Jeffrey A. Nelson

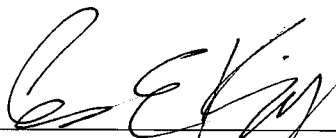

Notary Public
My commission expires: 2/10/2019





STATE OF VERMONT

AGENCY OF NATURAL RESOURCES

Department of Fish and Wildlife
 Department of Forests, Parks & Recreation
 Department of Environmental Conservation

Department of Environmental Conservation
 Water Quality Division
 111 West Street
 Essex Jct., VT 05452

FAX 802-879-3871

TEL 802-777-5328

e-mail: chris.brunelle@state.vt.us

June 9, 2014

STATUTORY AUTHORITY
 10 V.S.A. CHAPTER 41, SUBCHAPTER 2,
 ALTERATION OF STREAMS

Vermont Gas Systems, Inc.
 ATTN: Charles W. Pughe
 POB 467
 Burlington, VT 05402

Re: SA-5-9029
 Vermont Gas Systems, Inc., Addison Natural Gas Project – Phase I, Chittenden
 and Addison Counties, Vermont

This project, consisting of installing a new natural gas transmission pipeline in Chittenden and Addison Counties (Transmission Mainline) and new distribution mainlines in Chittenden County and new distribution mainlines in Addison County (Distribution Mainlines) in a generally north-south direction known as Alternative 5b as presented in the Section 248 Natural Resources Report by VHB, and which will involve crossing of watercourses as located and described in the attached documents. The crossings associated with this project involving changing, altering or modifying the course, current, or cross section of any watercourse (perennial stream) by movement, fill, or excavation of ten cubic yards or more is hereby approved, under the above named statutes, subject to the following conditions:

1. This project shall be accomplished according to the plans which have been stamped "APPROVAL" by the Watershed Management Division. No changes shall be made to the approved plans without prior written approval from the permitting authority.
2. The contractor's equipment shall be clean and well maintained, free of fuel, hydraulic and gear oil leaks, especially if such equipment is to be used to work in or adjacent to the water.
3. Pumping from excavation areas shall be discharged to an overland area, settling basins or by other means such that the effluent shall be essentially clarified before reentering the stream flow.
4. Maintain all established vegetation possible.
5. Permittee shall contact the permitting authority (chris.brunelle@state.vt.us or 777-5328) prior to installation of this facility so that a pre-construction conference can be scheduled with the applicants engineer and contractor to discuss installation procedure.

6. Work in a watercourse shall be accomplished during the period June 1 - October 1.
7. The conditions of this permit shall be made a part of the bid package for prospective contractors and shall be made a part of the signed contract between the permittee and its selected contractor.
8. By acceptance of this permit the permittee agrees to allow representatives of the State of Vermont access to the property covered by the permit at reasonable times, for the purpose of ascertaining compliance with Vermont environmental and health statutes and regulations and with this approval.

Pursuant to 10 V.S.A. Chapter 220, any appeal of this decision must be filed with the clerk of the Environmental Division of the Superior Court within 30 days of the date of the decision. The Notice of Appeal must specify the parties taking the appeal and the statutory provision under which each party claims party status; must designate the act or decision appealed from; must name the Environmental Division; and must be signed by the appellant or their attorney. In addition, the appeal must give the address or location and description of the property, project, or facility with which the appeal is concerned and the name of the applicant or any permit involved in the appeal. The appellant must also serve a copy of the Notice of Appeal in accordance with Rule 5(b)(4)(B) of the Vermont Rules for Environmental Court Proceedings. For further information, see the Vermont Rules for Environmental Court Proceedings, available on line at www.vermontjudiciary.org. The address for the Environmental Division is: 2418 Airport Road, Suite 1, Barre, VT 05641 (Tel. # 802-828-1660).

This approval does not relieve you of the responsibility of obtaining permission from the affected property owners, nor the responsibility of obtaining other necessary State or Federal permits.

Dated at Montpelier, Vermont this 9th day of June, 2014

David K. Mears, Commissioner
Department of Environmental Conservation

By Mary L. Borg, Deputy Director for
Christopher Brunelle
Stream Alteration Engineer

VERMONT AGENCY OF NATURAL RESOURCES
STREAM ALTERATION INDIVIDUAL PERMIT APPLICATION

10 V.S.A. CHAPTER 41 SUBCHAPTER 2

Agency Use Only
Project #: _____
Receipt Date _____

Applicant Name Vermont Gas Systems, Inc., Attn: Charles W. Pughe

Mailing Address P.O. Box 467
Burlington VT 05402

Telephone: Home _____ Work (802) 951 - 0343 Mobile (802) 316 - 6826

Project Location: Town Multiple locations, see attached materials Stream Multiple locations, see attached materials

Nearby town highway or state route Multiple locations, see attached materials ****ATTACH MAP****

I am hereby applying for the following type of project (check all that apply):

- Gravel Removal _____ cubic yards
- Streambank Stabilization Work
- Stream Channel Relocation
- Gold Dredging/Mineral Prospecting
- Other (describe): _____
- Temporary Diversion of Stream
- Bridge/Culvert Construction
- Utility Crossing (water, sewer) (Natural Gas Pipeline)
- Water/Sewer Outfall/Intake

Project Description: The project would consist of 41.1 miles of new natural gas Transmission Mainline, Magnitude (length, volume, etc.) 5.1 miles of Distribution Mainline, three new Gate Stations and five new mainline valves.

Purpose To expand natural gas availability in Vermont.

Construction Procedure Horizontal directional drilling and open trench construction methods will be employed. Please see attached EPSC Plans for construction details and locations where each construction type will be used.

Erosion/Sediment/Water Control Procedure Please see attached EPSC Plans for erosion, sediment, and water control procedures that will be used at each location.

ATTACH 2 COPIES : layout plan, typical or surveyed cross sections, stream profile and pertinent hydraulic or hydrologic information.

Excavating Contractor To Be Determined Phone N / A

Consultant/Project Supervisor VHB, Inc., Attn: Robert Wildey Phone (802) 497 - 6164

Expected Working Dates: Start April 2014 Completion December 2014 # Days Work To Be Determined

Name and addresses of landowners adjacent to or across the stream from the project: Signatures are necessary if you intend to work on adjacent property or if the project will directly affect the property of others.

Name _____ Address Please see attached abutter information and EPSC Plans.

Name _____ Address _____

Name _____ Address _____

****APPLICANT MUST FILE COPY OF THIS APPLICATION WITH TOWN CLERK AND ADJOINERS****

CERTIFICATION: I hereby certify that the information on this application is, to the best of my knowledge, true and accurate and that I have forwarded a copy of this application to the Town Clerk of the town in which this project is to occur and to each landowner adjoining or across the stream from the project area as required in 10 V.S.A. Chapter 41, Section 1022. I recognize that by signing this application I am giving consent to employees of the State to enter the subject property for the purpose of processing this application and for ensuring the compliance with subsequent agency decisions relation to the project.

Signature of Applicant *Charles W. Pughe* Date 10/4/2013

Print Full Name CHARLES W. PUGHE

NOTE: A PERMIT MAY BE REQUIRED FROM THE US ARMY CORPS OF ENGINEERS. For information contact: US Army Corps of Engineers, VT Project Office, 8 Carmichael Street Suite 205, Essex Jct VT 05452

ENCLOSE \$225.00 APPLICATION FEE PAYABLE BY CHECK OR MONEY ORDER TO THE "STATE OF VERMONT"
MUNICIPALITIES ARE EXEMPT FROM FEE

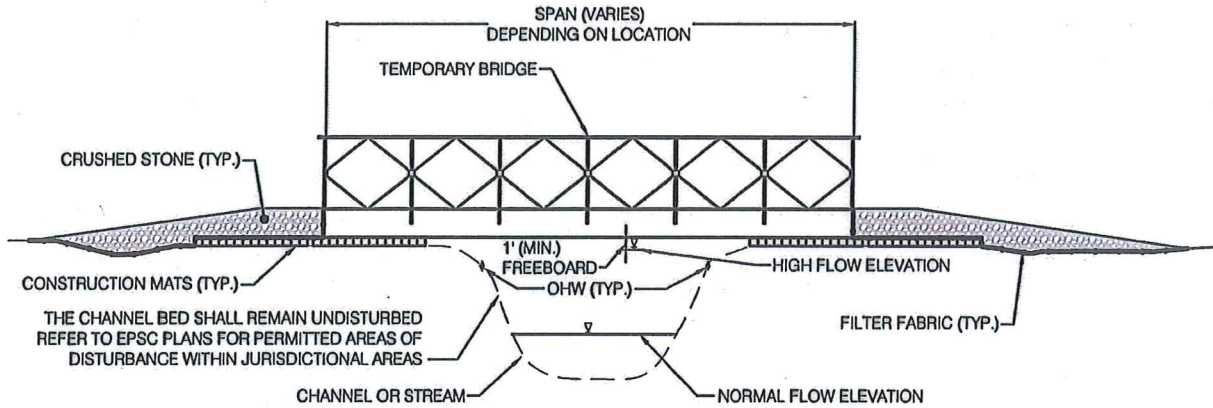

NOTES:

1. BRIDGE SHALL BE DESIGNED TO PROVIDE A CLEAR SPAN THAT IS EQUAL TO OR GREATER THAN OHW AT THE CROSSING SITE.
2. NO MATERIALS SHALL BE PLACED IN THE CHANNEL BELOW OHW WITHOUT PRIOR AUTHORIZATION.
3. BRIDGE SHALL BE DESIGNED TO CARRY THE MAXIMUM ANTICIPATED CONSTRUCTION LOADS. HOWEVER SHALL NOT BE LESS THAN AASHTO HS-25 LOADING CRITERIA.
4. BRIDGE SHALL BE DESIGNED SUCH THAT A MINIMUM ONE FOOT (1 FT) OF FREE BOARD EXISTS BETWEEN THE LOWEST MEMBER AND THE ANTICIPATED HIGH FLOW (Q25) WATER ELEVATION.

5. ADDITIONAL LOAD BEARING DEVICES BEYOND CONSTRUCTION MATTING MAY BE REQUIRED. THE CONTRACTOR SHALL CONDUCT A GEOTECHNICAL ANALYSIS OF EACH BRIDGE SITE TO DETERMINE THE NECESSARY BEARING CAPACITY OF SOILS AND TO DETERMINE THE MINIMUM DISTANCE BETWEEN BEARING SURFACES AND THE TOP OF STREAM/CHANNEL BANK.
6. APPROACH GRADES SHALL BE AS DEEMED NECESSARY BY THE CONTRACTOR.

APPROVAL
WATERSHED MANAGEMENT DIVISION
 DATE 3/10/14 10F5
 BY C. Brunelle
 THIS APPROVAL IS SUBJECT TO THE TERMS AND CONDITIONS OF STREAM ALTERATION PERMIT# SA-5-9029 ISSUED HEREWITH

Temporary Bridge Detail

N.T.S.

Source: VHB

LD_

Vanasse Hangen Brustlin, Inc.



Vermont Gas

VERMONT GAS

ADDISON NATURAL GAS PROJECT - PHASE I

STREAM ALTERATION / FLUVIAL EROSION HAZARD REVIEW

SELECTED DETAILS

December 20, 2012

REV 1 - MAY 3, 2013

FOR COMPLETE PROJECT PLANS AND DETAILS, PLEASE REFER TO THE EPSC PLAN SET



VERMONT GAS

ADDISON NATURAL GAS PROJECT - PHASE I

STREAM ALTERATION / FLUVIAL EROSION HAZARD

SELECTED DETAILS

FOR COMPLET
PLEASE REFER

NOTES:

1. USE DIVERSION FLUME STREAM CROSSING ON WATER COURSES WITH LIMITED STREAM FLOW TO PREVENT SEDIMENTATION AND INTERRUPTION OF STREAM FLOW DURING CONSTRUCTION. THIS METHOD IS APPROPRIATE IN LOCATIONS WHERE FISH PASSAGE IS A CONCERN.
2. SCHEDULE CONSTRUCTION DURING LOW FLOW PERIOD, IF POSSIBLE.
3. THIS DETAIL REPRESENTS ONE POSSIBLE CONFIGURATION OF CONSTRUCTION ELEMENTS WITHIN THE TEMPORARY AND PERMANENT ROW. ALTERNATE CONFIGURATIONS OF CONSTRUCTION ELEMENTS BETWEEN THE UPSTREAM AND DOWNSTREAM DIVERSION STRUCTURES ARE ALLOWABLE, SO LONG AS APPROPRIATE MEASURES ARE MAINTAINED TO PROTECT WATER QUALITY.
4. SET UP STEEL OR HDPE PIPE, AS SHOWN, OR USE PRACTICAL ALTERNATIVES. PIPE (OR PIPES) MUST BE SIZED TO HANDLE THE CAPACITY OF ANTICIPATED FLOW. DEPENDS ON THE CAPACITY OF ANTICIPATED FLOW TO CONCENTRATE WATER AT INTAKE.
5. INSTALL UPSTREAM DAM COMPOSED OF SANDBAGS, METAL PLATING OR A COMBINATION OF BOTH. INSTALL DOWNSTREAM DAM, IF REQUIRED, TO KEEP STREAM BED DRY.
6. AFTER DAMS ARE IN PLACE, IT MAY BE NECESSARY TO USE A SUMP PUMP AND DEWATERING FILTER BAG TO KEEP WORK AREA DRY.
7. ALL MECHANIZED EQUIPMENT TO PERFORM WORK FROM ADJACENT TOP OF BANK AREAS. MAT STREAM IF WORK TO OCCUR IN STREAM CHANNEL.
8. EXCAVATE TRENCH AND LOWER IN PIPE UNDER DIVERSION FLUME. MOVE FLUME AS REQUIRED OR DISCONNECT IF TEMPORARY FLOW BLOCKAGE IS ACCEPTABLE. BACKFILL TRENCH.
9. DISMANTLE DOWNSTREAM DAM, THEN UPSTREAM DAM.
10. RESTORE DISTURBED CHANNEL, STREAM BANKS, AND APPROACHES FOR A MINIMUM DISTANCE OF AT LEAST 50 FT. FROM THE STREAM EDGES AND PERMANENTLY STABILIZE WITHIN 1 DAY OF INITIAL RESTORATION. REFER TO THE STREAMBANK RESTORATION DETAIL FOR RESTORATION REQUIREMENTS.

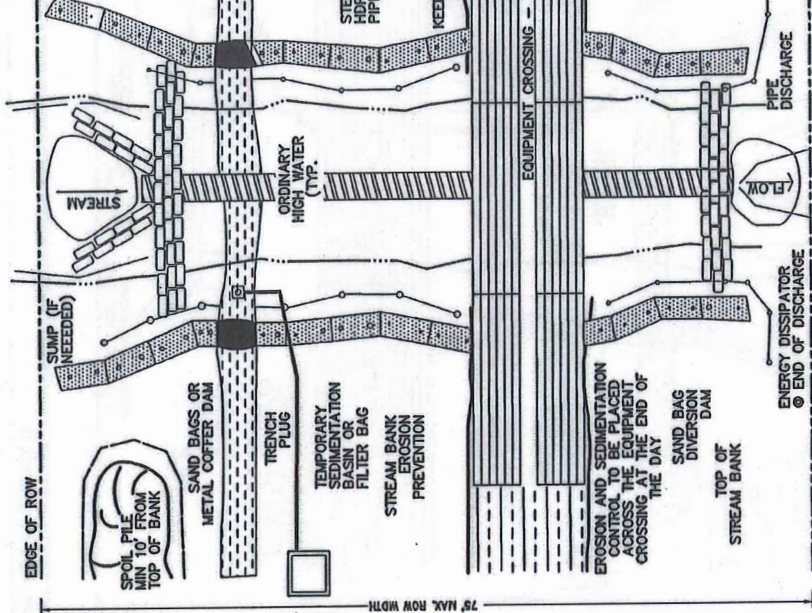



VERMONT GAS

ADDISON NATURAL GAS PROJECT - PHASE I
STREAM ALTERATION / FLUVIAL EROSION HAZARD
SELECTED DETAILS

FOR PLEA

APPROVAL
WATERSHED MANAGEMENT DIVISION

DATE 3/10/14 30F5

BY C. Bannelle

**THIS APPROVAL IS SUBJECT TO THE TERMS
AND CONDITIONS OF STREAM ALTERATION
PERMIT # SA-5-9029 ISSUED HERewith**

NOTES:

1. USE DAM AND PUMP METHOD ON WATER COURSES WITH LIMITED STREAM FLOW TO PREVENT SEDIMENTATION AND DISRUPTION OF STREAM FLOW DURING CONSTRUCTION.
2. SCHEDULE CONSTRUCTION DURING LOW FLOW PERIOD, IF POSSIBLE. PUMP AROUND TO BE USED ONLY DURING ACTIVE CONSTRUCTION. PUMP AROUND SYSTEM SHALL NOT BE LEFT UNATTENDED.
3. THIS DETAIL REPRESENTS ONE POSSIBLE CONFIGURATION OF CONSTRUCTION ELEMENTS WITHIN THE TEMPORARY AND PERMANENT ROW. ALTERNATE CONFIGURATIONS OF CONSTRUCTION ELEMENTS BETWEEN THE UPSTREAM AND DOWNSTREAM SAND BAG DIVERSION DAMS ARE ALLOWED AS LONG AS APPROPRIATE MEASURES ARE MAINTAINED TO PROTECT WATER QUALITY.
4. SET UP PUMP AND HOSE AS SHOWN, OR USE ANCHORED PUMP. PUMP SHOULD HAVE TWICE THE PUMPING CAPACITY OF ANTICIPATED FLOW. STANDBY PUMP ON SITE, DEPENDING ON STREAM FLOW, DIG SUMP HOLE TO CONCENTRATE WATER AT INTAKE.
5. USE TEMPORARY SEDIMENTATION BASIN OR FILTER BAG PRIOR TO DISCHARGING WATER BACK TO STREAM.
6. INSTALL UPSTREAM DAM COMPOSED OF SANDBAGS, METAL PLATING OR A COMBINATION OF BOTH, INSTALL DOWNSTREAM DAM, IF REQUIRED, TO KEEP STREAM BED DRY.
7. AFTER DAMS ARE IN PLACE, IT MAY BE NECESSARY TO USE ADDITIONAL PUMPS TO HANDLE STREAM FLOW.
8. EXCAVATE TRENCH AND LOWER IN PIPE UNDER HOSE. BACKFILL TRENCH.
9. ALL MECHANIZED EQUIPMENT TO PERFORM WORK FROM TEMPORARY BRIDGE OR TOGETHER TOP OF BANK AREAS. USE TIMBER MATS TO OCCUR IN STREAM CHANNEL.
10. DISMANTLE DOWNSTREAM DAM, THEN UPSTREAM DAM.
11. RESTORE DISTURBED CHANNEL, STREAM BANKS AND APPROACHES FOR A MINIMUM DISTANCE OF AT LEAST 50 FT. FROM THE STREAM EDGES AND PERMANENTLY

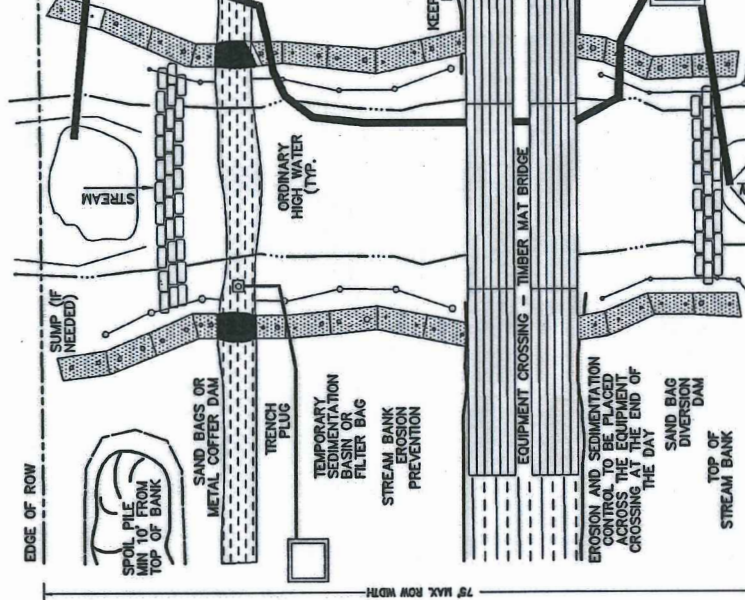

MILEPOST	STREAM NAME	CHANNEL WIDTH (A)	FEH WIDTH (B)	HDD LENGTH (C)	CHANNEL ELEV. (D)	ELEV. BELOW CHANNEL (E)	ENTRY ELEV. (F)	EXIT ELEV. (G)
0.99	INDIAN BROOK	4	100	1,150	208 ¹	< 198	< 208	< 208
1.52	INDIAN BROOK	15	125	1,530	188 ²	< 178	< 188	< 188
3.62	INDIAN BROOK	7	N/A (185)	370	430 ²	< 420	< 430	< 430
6.75	WINOOSKI RIVER (SECTION 10 WATERS)	320	N/A (1,195)	900	263 ³	< 238	< 275	< 275
10.32	ALLEN BROOK	35	360	400	376 ²	< 366	< 376	< 376
19.47	LAPLATTE RIVER	30	360	640	317 ²	< 307	< 317	< 317
22.86	LEWIS CREEK	80	435	2,500	310 ¹	< 300	< 310	< 310
35.85	UNNAMED TRIB. TO LITTLE OTTER CREEK	4	640	1,010	303 ²	< 293	< 303	< 303
39.30	NEW HAVEN RIVER	120	785	530	245 ²	< 235	< 245	< 245

1. CHANNEL ELEVATION BASED ON CONTOURS SHOWN ON EPSC PLAN PROVIDED BY CHA, INC. DATED 02/28/2013 AND NOT ASSESSED IN THE FIELD BY VHB.
 2. CHANNEL ELEVATION BASED ON CONTOURS SHOWN ON EPSC PLAN PROVIDED BY CHA, INC. DATED 02/28/2013 AND MODIFIED BASED ON FIELD ASSESSMENT BY VHB.
 3. CHANNEL ELEVATION BASED ON BATHYMETRIC SURVEY PROVIDED BY COLER & COLANTONIO DATED 12/12/2012 AND NOT ASSESSED IN THE FIELD BY VHB.

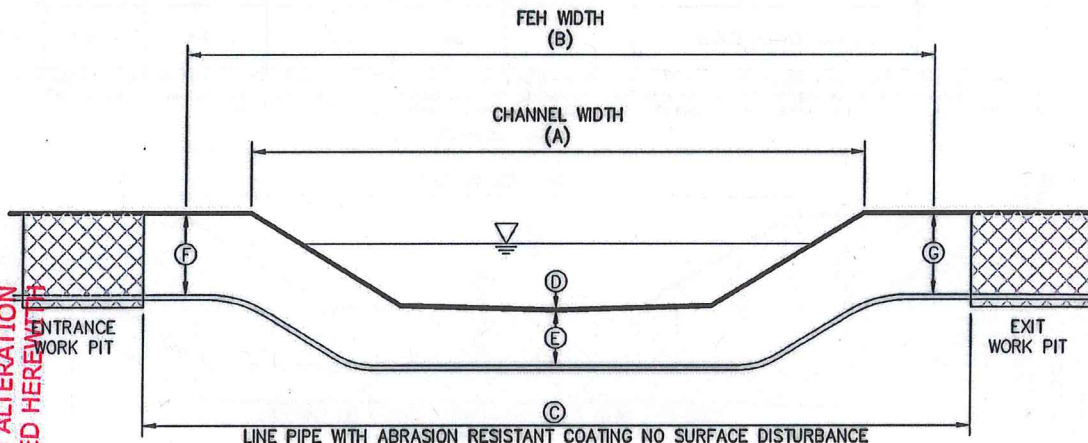

Notes:

THIS CONFIGURATION IS FOR HORIZONTAL DIRECTIONAL DRILL OF STREAM CROSSINGS AS SHOWN ON PROJECT PLANS. SEE ALIGNMENT SHEETS FOR LOCATIONS OF THIS CONFIGURATION.
 TOP OF PIPELINE MUST BE AT LEAST AS DEEP AS THE CHANNEL BOTTOM (DIMENSION D) THROUGHOUT THE FLUVIAL EROSION HAZARD (FEH) CORRIDOR.
 MINIMUM SEPARATION BETWEEN THE TOP OF PIPELINE AND THE CHANNEL BOTTOM (DIMENSION E) MUST BE AT LEAST 7 FEET.
 ELEVATIONS PROVIDED ARE BASED ON APPROXIMATE NAVD 88 DATUM AND MUST BE FIELD VERIFIED PRIOR TO INSTALLATION OF PIPELINE.
 FEH CORRIDOR IS LISTED AS NOT APPLICABLE (N/A) WHERE THE STREAM CROSSES OR IS ADJACENT TO AN EXISTING ROADWAY OR OTHER INFRASTRUCTURE THAT RESULTS IN RIVER MANAGEMENT CONSTRAINTS AT THAT LOCATION. FEH CORRIDOR WIDTHS AT THESE LOCATIONS ARE SHOWN FOR INFORMATION PURPOSES ONLY.

APPROVAL
 WATERSHED MANAGEMENT DIVISION
 DATE 3/10/14
 BY C. Brunelle
 40eS

THIS APPROVAL IS SUBJECT TO THE TERMS AND CONDITIONS OF STREAM ALTERATION PERMIT # SA-15-0027 ISSUED HEREIN.

Horizontal Directional Drill (HDD) Stream Crossing - Typical Section

04/13

N.T.S.

Source: VHB

Vanasse Hangen Brustlin, Inc.



Vermont Gas

VERMONT GAS

ADDISON NATURAL GAS PROJECT - PHASE I

STREAM ALTERATION / FLUVIAL EROSION HAZARD REVIEW

SELECTED DETAILS

December 20, 2012

REV 1 - MAY 3, 2013

FOR COMPLETE PROJECT PLANS AND DETAILS, PLEASE REFER TO THE EPSC PLAN SET

MILEPOST	STREAM NAME	CHANNEL WIDTH (A)	FEH WIDTH (B)	CHANNEL ELEV. (C)	ELEV. BELOW CHANNEL (D)	ENTRY ELEV. (E)	EXIT ELEV. (F)
5.04	ALDER BROOK	50	N/A (80)	N/A - NOT CROSSING IN CHANNEL			
6.14	ALDER BROOK	40	N/A (190)	N/A - NOT CROSSING IN CHANNEL			
6.60	ALDER BROOK	35	N/A (150)	281 ¹	< 274	< 281	< 281
13.79	SUCKER BROOK	15	120	367 ²	< 360	< 367	< 367
18.93	UNNAMED TRIBUTARY TO LAPLATTE RIVER	4	N/A (310)	328 ¹	< 321	< 328	< 328
19.94	UNNAMED TRIBUTARY TO LAPLATTE RIVER	4	125	330 ²	< 323	< 330	< 330
24.52	UNNAMED TRIBUTARY TO LEWIS CREEK	8	N/A (200)	407 ³	< 400	< 407	< 407
29.11	UNNAMED TRIBUTARY TO LITTLE OTTER CREEK	8	N/A (400)	362 ²	< 355	< 362	< 362
30.94	UNNAMED TRIBUTARY TO LITTLE OTTER CREEK	4	200	267 ²	< 260	< 267	< 267
32.30	LITTLE OTTER CREEK	35	240	267 ¹	< 260	< 267	< 267

1. CHANNEL ELEVATION BASED ON CONTOURS SHOWN ON EPSC PLAN PROVIDED BY CHA, INC. DATED 02/28/2013 AND MODIFIED BASED ON FIELD ASSESSMENT BY VHB.
 2. CHANNEL ELEVATION BASED ON CONTOURS SHOWN ON EPSC PLAN PROVIDED BY CHA, INC. DATED 02/28/2013 AND NOT ASSESSED IN THE FIELD BY VHB.
 3. CHANNEL ELEVATION BASED ON TOPOGRAPHIC INFORMATION FROM GOOGLE EARTH AND NOT ASSESSED IN THE FIELD BY VHB.

APPROVAL
 WATERSHED MANAGEMENT DIVISION
 DATE 3/10/14
 BY C. Brundage
 5075

THIS APPROVAL IS SUBJECT TO THE TERMS AND CONDITIONS OF STREAM ALTERATION PERMIT # SA 5-1029 ISSUED HEREWITH

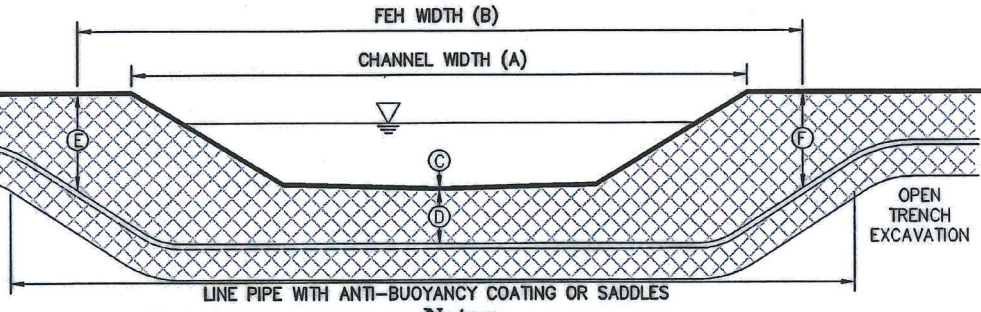

Notes:
 THIS CONFIGURATION IS FOR OPEN TRENCH EXCAVATION OF STREAM CROSSINGS AS SHOWN ON PROJECT PLANS. SEE ALIGNMENT SHEETS FOR LOCATIONS OF THIS CONFIGURATION.
 TOP OF PIPELINE MUST BE AT LEAST AS DEEP AS THE CHANNEL BOTTOM (DIMENSION D) THROUGHOUT THE FLUVIAL EROSION HAZARD (FEH) CORRIDOR.
 MINIMUM SEPARATION BETWEEN THE TOP OF PIPELINE AND THE CHANNEL BOTTOM (DIMENSION E) MUST BE AT LEAST 7 FEET.
 ELEVATIONS PROVIDED ARE BASED ON APPROXIMATE NAVD 88 DATUM AND MUST BE FIELD VERIFIED PRIOR TO INSTALLATION OF PIPELINE.
 FEH CORRIDOR IS LISTED AS NOT APPLICABLE (N/A) WHERE THE STREAM CROSSES OR IS ADJACENT TO AN EXISTING ROADWAY OR OTHER INFRASTRUCTURE THAT RESULTS IN RIVER MANAGEMENT CONSTRAINTS AT THAT LOCATION. FEH CORRIDOR WIDTHS AT THESE LOCATIONS ARE SHOWN FOR INFORMATION PURPOSES ONLY.
 6. RESTORE DISTURBED CHANNEL, STREAM BANKS, AND APPROACHES FOLLOWING PIPELINE INSTALLATION PER EPSC PLAN.

Open Trench Stream Crossing - Typical Section

04/13

N.T.S.

Source: VHB



Vermont Gas

VERMONT GAS
 ADDISON NATURAL GAS PROJECT - PHASE I
 STREAM ALTERATION / FLUVIAL EROSION HAZARD REVIEW
 SELECTED DETAILS

Vanasse Hangen Brustlin, Inc.

December 20, 2012
 REV 1 - MAY 3, 2011

FOR COMPLETE PROJECT PLANS AND DETAILS, PLEASE REFER TO THE EPSC PLAN SET

Transportation
 Land Development
 Environmental
 Energy
 S e r v i c e s



7056 US Route 7
 Post Office Box 120
 North Ferrisburgh, Vermont 05473
 802.497.6100
 Fax 802.425.7799

Memorandum

To: Vermont Gas Systems, Inc.
 Addison Natural Gas Project

Date: December 13, 2012
 Last Revised: June 26, 2013

Project No.: 57563.00

From: Robert Wildey

Re: VGS Addison Natural Gas Project Phase I
 Stream Alteration/FEH Review
 Documentation

This memorandum addresses updates and modifications to the Vermont Gas Systems, Inc. ("VGS") Addison Natural Gas Project ("ANGP" or "Project") Stream Alteration/FEH Documentation memorandum provided to the Vermont Public Service Board ("PSB") as Exhibit Petitioner JAN-7 on December 20, 2012. This updated memorandum provides new information pertinent to changes in the Project components as a result of pipeline realignments, collectively referred to as the "6/28/13 Alignment".

The 6/28/13 alignment (also referred to as Alternative 5b) is shown in the Erosion Prevention Sediment Control ("EPSC") plans and other materials submitted to the Public Service Board ("PSB") on June 28, 2013. The original ANGP Phase I alignment ("Alternative 5a") was submitted to the PSB on December 20, 2012 and was revised as a result of stakeholder input and renamed Alternative 5b¹. The alignment for Alternative 5b was submitted to the PSB on February 28, 2013 and has subsequently undergone additional refinements to further reduce resource impacts, address stakeholder concerns, and to address constructability constraints that are detailed in Alternative 5b. Collateral permit applications for ANGP Phase I were filed with Vermont Department of Environmental Conservation ("VT DEC") and U.S. Army Corps of Engineers on May 3, 2013 which memorialize project changes made between February 28, 2013 and May 3, 2013. The May 3, 2013 and current modifications to the Project, all described below, are considered to be minor adjustments or refinements of Alternative 5b, and thus do not represent a new Alternative.

At the request of VGS and in support of VGS's petition for a certificate of Public Good ("CPG") from the PSB, Vanasse Hangen Brustlin, Inc. ("VHB") conducted stream assessments for the

¹ For additional detail, refer to page 4 of the Supplemental Prefiled Testimony of Jeffrey Nelson dated February 28, 2013 (Addison Natural Gas Project, PSB Docket No. 7970).

proposed VGS ANGP Phase I which extends from Colchester to Middlebury, Vermont (see ANGP Index Map on page 1 of the Attachment). These assessments were conducted for the primary purpose of providing background information to support other permit applications collateral to the CPG petition.

As presented in the *Section 248 Natural Resources Report*² (“NR Report”) by VHB, the proposed VGS ANGP corridor has a north to south alignment that traverses through portions of twelve towns from Chittenden to Addison County. VGS is proposing to install approximately 41.2 miles of new natural gas transmission pipeline in Chittenden and Addison Counties (Transmission Mainline) and approximately 0.1 miles of new distribution mainlines in Chittenden County and 5.0 miles of new distribution mainlines in Addison County (Distribution Mainlines); construct less than a quarter mile permanent access road to the point of interconnection with the existing VGS transmission pipeline in Colchester (Colchester Tie-In); construct three new gate stations in Williston, New Haven, and Middlebury; and five stand-alone mainline valves (“MLV”) sites. The following is an overview of each of these major project components. Additional components of the overall project include temporary access roads that will largely utilize existing roads (e.g., farm roads), temporary laydown/staging areas, and several smaller laydown/staging areas typically located adjacent to the project corridor.

As described and detailed in the NR Report, VHB environmental scientists conducted field delineation and assessment of stream features between July and November 2012. Due to proposed realignments of the Transmission Mainline, additional study areas were added in early 2013. Additional stream crossings were evaluated during an unseasonal thaw in January 2013 and in April 2013. VHB gathered available mapping information and conducted a preliminary assessment to determine the approximate extent of any stream resources in January and February 2013. This review relied on a combination of information gathering, field site visits with reconnaissance level wetland verification and mapping, and overlay/digitizing of previous stream mapping by others. Reconnaissance level stream features will be field-verified once permission for access is obtained to inspect the unsurveyed stream crossings that would occur on private property.

The stream assessment review focused on locations where the proposed natural gas transmission pipeline would cross a perennial stream with a watershed area of 1.0 square mile or greater, i.e., locations that would otherwise require an application to the VT DEC under the Vermont Stream Alteration General Permit³. This memorandum is intended to supplement

² VHB. February 2013. Section 248 Natural Resources Report – Vermont Gas Systems, Inc. Addison Natural Gas Project. Technical Report submitted to the PSB and made part of the Section 248 Petition and its associated collateral permits.

³ The Stream Alteration General Permit includes a specific exemption under Section C.1.8 for “Energy-related projects regulated under the authority of 30 V.S.A § 248.” Review and comment by the DEC River Management Program is anticipated in order to assist the PSB in confirming that the proposed project meets the requirements of 10 V.S.A. § 6086.

VHB's NR Report and present the findings of the stream crossing assessments. A description of the assessment methods used and findings of the work are presented below.

Methodology

In consultation with the VT DEC River Management Program, the stream alteration review process consisted of the following steps:

- identified the specific locations where the proposed pipeline crossed stream channels
- conducted field delineation of ordinary high water ("OHW") at each site
- evaluated the fluvial erosion hazard ("FEH") corridor
- proposed alternative route locations or site modifications in order to minimize impacts

The initial investigation of stream crossing locations was performed through a Geographic Information System ("GIS") analysis. This approach identified intersections between the preliminary pipeline alignment and the streams included in the 2008 Vermont Hydrography Dataset ("VHD") shape file maintained by the Vermont Center for Geographic Information ("VCGI")⁴. These locations were further evaluated using topographic data and the watershed sizes maps published by the Vermont River Management Program⁵ to determine the size of the watershed at each crossing location.

Field delineation of OHW was conducted in conjunction with the natural resources mapping in the NR Report. In addition, geomorphic field surveys were conducted at most crossing sites with upstream watershed areas greater than 1.0 square mile. These field surveys included cross sections at the site of the proposed crossing and a longitudinal profile of the channel extending upstream and downstream from the proposed crossing. Bank stability, vegetation type, and sediment characterization were recorded in conjunction with the geomorphic survey. Landowner access issues or other constraints limited access to some sites and desktop GIS analysis or windshield surveys were conducted if detailed field work was not possible. The results of these evaluations are included in the attached Summary of Stream Crossings for Alternative 5b on page 2 of the Attachment and were used to further refine the design of each stream crossing.

Consideration of FEH corridors during the Project design process represents an important opportunity to ensure protection of the natural values of rivers and to maintain river processes. The intent of the Project's design within the FEH corridor is to not interfere with the ability of the channel to fluctuate in dynamic equilibrium, thereby avoiding costly failures or the need to impose potentially unsustainable river management practices over the long term. Fluvial erosion hazard mapping for most stream crossing sites with watershed areas greater than

⁴ Vermont Center for Geographic Information, 2008. Accessed online at http://www.vcgi.org/pub/dataware/gisdata/layers_vcgi/WaterHydro_VHD.zip

⁵ Vermont DEC River Management Program. Accessed online at http://www.anr.state.vt.us/dec/waterq/rivers/htm/rv_management.htm.

1.0 square mile was provided to the project by the VT DEC. At the stream crossing sites where mapping was provided, the site topography, soils, and existing infrastructure constraints were compared with additional mapping resources and field investigations to confirm that the mapped FEH accurately reflected conditions at the site. If there was a significant discrepancy, the FEH was modified according to the procedures provided in the River Corridor Protection Guide (VT ANR, 2008)⁶.

VT DEC does not generally develop FEH polygons for streams with watershed areas smaller than 2.0 square miles⁷. In order to analyze potential FEH constraints throughout the project area, VHB developed supplemental FEH polygons for locations where the proposed alignment crossed or was adjacent to streams with watershed areas between 1.0 and 2.0 square miles. The FEH polygons developed by VHB follow the Step 1 corridor delineation methodology outlined in the Vermont River Corridor Protection Guide Technical Appendix⁸. Locations where supplemental FEH polygons were generated were generally for smaller streams (average bankfull width less than 10 feet) and the polygons were drawn conservatively, with a minimum offset from the stream centerline of 50 feet. In locations where it was necessary to extend an existing FEH polygon that had been provided by VT DEC, the supplemental polygons were drawn at least as wide as those provided for other reaches of the same stream.

Within one meander length (10 bankfull widths) of a road, bridge, or other major infrastructure, it is understood that the river is already being actively managed and it is assumed that the channel will not be permitted to fully migrate across the FEH. Following additional consultation with DEC, the mapped FEH corridors were trimmed 10 bankfull widths in the vicinity of public roadways. In these locations, the roadway embankment and cross culvert acts as the valley wall and constrain the migration of the river system.

Once natural resources and stream assessment field work was underway, modifications to the preliminary alignment were proposed where potentially-avoidable natural resources impacts were identified. The proposed modifications included alternate routing (e.g., working within a roadway embankment instead of across the toe of the embankment or extending the route around the feature), construction method modifications (e.g., changing from an open trench crossing to a horizontal directional drilling ("HDD") crossing), or calling for increased pipeline burial depth across the width of the FEH. Collectively, these changes resulted in the revised alignment presented in the Section 248 petition and collateral permit applications.

⁶ Vermont DEC, 2008. River Corridor Protection Guide: Fluvial Geomorphic-Based Methodology to Reduce Flood Hazards and Protect Water Quality.

⁷ Pytlik, Shannon (VT DEC) January 30, 2013. Personal communication.

⁸ Vermont DEC, 2008. River Corridor Protection Guide: Fluvial Geomorphic-Based Methodology to Reduce Flood Hazards and Protect Water Quality.

Results

Number of crossings

Based on the field delineations conducted in support of the NR Report, the Transmission Mainline would result in a total of 47 perennial or intermittent streams crossings, including nine crossings of VHD named streams⁹ (see Summary of Stream Crossings for Alternative 5b, page 2 of the Attachment). The revised alignment would result in one fewer stream crossing than was proposed under the 12/20/2012 alignment. At locations where the pipeline would cross streams with smaller watersheds, potential impacts are likely to be minor and will be minimized or avoided through construction phase Best Management Practices (“BMPs”) which are described in the Erosion Prevention and Sediment Control (“EPSC”) plan for the Project. Crossings at larger streams tend to involve more complex construction activities and longer periods of potential exposure that must be managed to avoid impacts to aquatic resources. Therefore, VHB focused on the larger streams crossings and evaluated potential concerns at these sites. Of the 47 stream crossings, 21 occur at sites with contributing watershed areas greater than 1.0 square mile, one fewer than was proposed under the 12/20/2012 alignment. Seven of the crossings previously considered have been modified in either location or crossing type. Fourteen of the crossings previously considered remain unchanged. Additional information about these larger crossings is summarized in the Summary of Stream Crossings with watersheds greater than 1.0 square mile, page 3 of the Attachment.

Fluvial Erosion Hazard Corridors

VT DEC provided FEH corridor polygons for 13 locations where the proposed alignment would cross a stream with a watershed greater than 1.0 square mile. The proposed alignment would result in 6 stream crossings that occur within or adjacent to an existing roadway right-of-way that already impacts the FEH corridor defined by VT DEC. As described above, the mapped FEH corridors were trimmed by 10 bankfull widths at these locations. Although conservative burial depths below the channel thalweg are proposed across the project, the depth of burial at the edge of the FEH corridor may be reduced in locations where the valley wall is defined by existing infrastructure. In these locations, the presence of the pipeline would not alter the management regime that is in place to protect the existing infrastructure. One of these polygons (Crossing 116 at Allen Brook) was also slightly modified upon review of the detailed contours that were available in the vicinity of the crossing. FEH corridor polygons were generated for the remaining 8 crossings larger than 1.0 square mile that were not provided by VT DEC, including those with watershed sizes between 1.0 and 2.0 square miles for which VT DEC does not typically generate FEH polygons.

At the request of VT DEC, the overall pipeline alignment was reviewed for locations where the pipeline would run parallel to streams with watershed areas greater than 1.0 square mile and would potentially cross the associated FEH, in addition to locations where the proposed pipeline would be perpendicular to and would cross mapped streams. Such parallel alignment

⁹ Vermont Center for Geographic Information, 2008. Vermont Hydrography Dataset (VHD) Streams.

locations would require the same protection against future lateral or vertical migration of the stream as a perpendicular crossing. Separation between the proposed pipeline route and the FEH polygons was confirmed using GIS tools. Five locations were identified where the proposed pipeline alignment intersected an FEH polygon or was within 100 feet of it. Three locations occur in conjunction with previously-identified crossings of smaller, low gradient streams (bankfull width less than 10 feet), where the proposed pipeline alignment would run parallel to the stream channel for some distance on either side of the proposed crossing. Two other locations would occur at sites where a supplemental FEH was developed for the stream corridor using GIS remote-sensing data; however, the results of the NR field investigation indicates that the sites are both within large wetland complexes lacking well-defined stream channels. According to information provided by VT DEC, the FEH belt-width approach is not accurate within wetland areas where a defined stream channel is not present. A summary of these locations are presented below in Table 1.

Table 1. Proposed Alignment Parallel to Supplemental FEH Corridor				
Milepost	Town	Location	Min. Distance from FEH	FEH Description
18.5 to 19.0	Hinesburg	Unnamed tributary to LaPlatte River, north of Crossing 20	75 feet	Low-gradient stream. Pipeline would be within FEH for ± 300 feet at Crossing 20. Beyond of FEH, the pipeline would be ± 75 feet outside of and parallel to the FEH for an additional ± 800 feet. This area includes Prime Agricultural Soils ("PAS") and pipeline would be buried 48 inches deep per PAS construction requirements.
20.5 to 21.0	Hinesburg	Unnamed tributary to LaPlatte River, south of Crossing 123	65 feet	Low-gradient stream in agricultural field. Point nearest the pipeline would be at the outside of an existing meander bend. This area includes PAS and pipeline would be buried 48 inches deep per PAS construction requirements.
24.0 to 24.5	Monkton	Unnamed tributary to Lewis Creek, north of Crossing 107	0 feet	Low-gradient stream in agricultural field. Pipeline would continue within FEH for ± 200 feet beyond stream crossing. Pipeline would be buried as deep as channel bottom in this area, per stream crossing construction detail.
27.0 to 28.0	Monkton	Unnamed tributary to Little Otter Creek, north of Crossing 32	N/A	Site of large wetland system without defined stream channel. Approximate FEH shown for graphical purposes only. Wetland would be crossed by a horizontal directional drill and would be more than 10 feet below wetland.
36.5 to 37.0	New Haven	Unnamed tributary to Little Otter Creek, south of Crossing 43	N/A	Site of large wetland system without defined stream channel. Approximate FEH shown for graphical purposes only. Pipeline would be buried per standard wetland crossing construction detail.

At all other locations where the proposed pipeline alignment would run parallel to stream segments separately from identified stream crossings, the separation between the pipeline and the FEH polygon was found to be at least 100 feet. A map series illustrating the FEH polygons and their proximity to the proposed pipeline alignment is presented on pages 4 through 10 of the Attachment.

Horizontal Directional Drilling

VT DEC has expressed that their preferred method for stream crossings is to use HDD, whereby impacts to the stream due to the pipeline installation can be completely avoided. HDD requires that two boreholes (a jacking pit and a receiving pit) be excavated on either side of the drilled segment, and also that there is sufficient distance for a length of pipe to be bent and fed through the jacking borehole. The entry and exit angle of the bent pipe, the channel width, and the required depth below the channel bottom are evaluated in order to determine the final length of the HDD segment. Additional length may be added to the HDD segment in order to avoid impacts to other resource areas, such as wetlands, FEH corridors, and archaeological sites near the crossing. This method is proposed for use at a total of 10 stream crossings sites where suitable soils, topography, and pipeline alignment permit it to be used, including 9 crossings of streams with watersheds greater than 1.0 square mile (Crossings 3, 9, 21, 122, 40 through 43, 44).

With the exception of the Winooski River crossing, all HDD stream crossings extend beyond the limits of the mapped or estimated FEH corridor associated with the stream crossing. At the Winooski River crossing, 900 feet of the total 1,195-foot wide FEH corridor will be drilled. This crossing occurs within 10 bankfull widths of the Route 117 roadway to the north and the New England Central Railroad right-of-way embankment to the south. The portion of the crossing within the FEH corridor that is proposed to be completed using open trench excavation is necessary to provide a transition onto the railway embankment that defines the valley wall and provides the right-of-way (ROW) for the next segment of pipeline.

Open Trench Excavation

The alternative method for stream crossings involves deploying temporary in-stream flow diversion structures, excavating an open trench across the stream channel, installing the pipeline, backfilling with suitable materials, and restoring the stream bank and channel bottom. This construction method resembles the method used to construct the remainder of the pipeline through upland areas, but involves added EPSC measures and increased burial depth to avoid and minimize impacts to the waterway. Typical details for Open Trench Diversion Flume Stream Crossings and Open Trench Dam and Pump Around Stream Crossings are included in the EPSC plans to manage flow associated with the open trench crossings. Channel substrate and stream bank soils will be segregated from subsurface spoils during the pipeline installation and soil horizons will be restored to the extent practicable within the 50-foot riparian buffer zone. Stream bank restoration details are included in the EPSC plans for use in stabilization and restoration at Open Trench stream crossing sites. Through the use of appropriate erosion control and sediment prevention measures, ditches, ephemeral, and dry intermittent streams may be crossed using open trench techniques with minimal impacts to the receiving water. Timber matting will be used to protect bordering wetlands and smaller stream channels from impacts by mechanized equipment.

Open trench stream crossings are proposed for use at a total of 35 stream crossing locations, including at 10 streams with watershed areas greater than 1.0 square mile. A brief description of these 10 stream crossings is provided below.

Two of the stream crossings of streams with watershed areas greater than 1.0 square mile occur in locations where the channel substrate consists of cobble and boulder till or bedrock (Alder Brook, Crossing 124 and Sucker Brook, Crossing 17). At these locations, open trench excavation would result in smaller impacts than may occur if an HDD crossing were proposed and minimal sediment release would be anticipated from in-stream work due to the type of substrates present.

The Indian Brook stream crossing adjacent to the Chittenden County Circumferential Highway ("CCCH") in Essex Junction (Crossing 4) was proposed as an HDD crossing in earlier submittals. Following further evaluation of the wetland impacts that would be associated with the pull-back area required for an HDD crossing, it was determined that an Open Trench crossing would minimize wetland impacts at this location. The proposed crossing would occur in a low-gradient reach of the stream with sandy silt and clay substrate that has downstream grade control provided by the inlet to the CCCH culvert.

The Allen Brook stream crossing adjacent to U.S. Route 2 in Williston (Crossing 116) was previously proposed as an HDD in earlier submittals. Following a refinement of the HDD design and associated pullback areas, it was determined that an HDD crossing could not be completed in this location without impacting an important archaeological site (VT-CH-197). Potential impacts to this archaeological site have been avoided through a redesign of this location as an open trench crossing, as the work area required to construct an open trench crossing would not extend into the archaeological site.

With the exception of sites constrained by existing substrate conditions or other resource concerns, the remaining stream crossings that are proposed for open trench excavation are generally smaller channels (OHW width less than 10 feet) that would be crossed within a single work day and without significant release of sediment. Of the stream crossings at locations with watershed areas greater than 1.0 square mile, four are located in open areas (Crossings 20, 123, 111, and 113) and two are adjacent to a roadway right-of-way (Crossings 107 and 32). Sufficiently protective erosion prevention and sediment control measures would be deployed to minimize sediment release during construction at Open Trench stream crossings. To maintain stream bank and channel stability, stream restoration measures would be installed immediately after each crossing is completed.

Avoided Crossings

Two locations identified as crossings (Crossings 6 and 8A) in fact involve no work in the stream channel as the pipeline is proposed to be installed above the culvert in the CCCH roadway embankment.

Aquatic Resources

Stream crossings sites were reviewed for potential impacts to rare, threatened, or endangered ("RTE") species. According to correspondence from the Vermont Fish & Wildlife Department, the only site with confirmed aquatic species of concern was found to be Lewis Creek (Crossing 122). This crossing has been proposed to be constructed with HDD in order to avoid impacts to these species.

Temporary Construction Crossings

Construction access for the Project has been designed so that most areas would use existing farm or maintenance roads to approach stream crossings from either direction without requiring construction of a bridge or other structure. All streams that would be crossed using open trench construction would be temporarily bridged during the construction process (Crossings 4, 17, 20, 32, 107, 111, 113, 116, 123, and 124). One stream that would be crossed using HDD construction would also be crossed at or near the pipeline crossing in order to facilitate construction access (Crossing 21). Streams with bankfull widths less than 14 feet would be crossed using mat bridges assembled from stacked construction matting. Five streams with watershed areas greater than 1.0 square mile and bankfull widths greater than 14 feet would be crossed using temporary bridge structures (Crossings 17, 21, 113, 116, and 124). All temporary bridge structures would be removed once construction was completed.

Conclusions

VHB performed stream crossing assessments for locations where the proposed transmission pipeline would cross a perennial stream with a watershed area of 1.0 square mile or greater. These assessments were undertaken to provide supporting information to DEC and the PSB regarding potential impacts to streams and aquatic resources associated with the Project.

The assessments were also used by the design team to identify locations where impacts could be minimized or avoided through the use of HDD techniques, locations where the channel substrate or bank materials present challenges that required additional design considerations to minimize impacts, locations where bedrock outcrops or other constraints would recommend altering the alignment, and identification of the FEH corridors for locations where an FEH has not been designated by VT DEC.

Based on the results of the assessments of these streams, 9 of the 21 stream crossings with watershed areas of 1.0 square mile or greater are proposed to be crossed with HDD techniques and will involve no in-stream work at the crossing site. Two crossings would occur within a roadway embankment and would cross above an existing culvert, thereby avoiding in-stream work. The remaining 10 stream crossings with watershed areas of 1.0 square mile or greater are proposed to be crossed with open trench excavation using stream diversion design details that have been reviewed and approved by the VT DEC Rivers Management staff. Through the use of these stream diversion structures and other appropriate EPSC measures, impacts to the receiving water will be avoided and minimized. The pipeline alignment has been routed to

minimize the distance where the pipeline alignment would be located within an FEH. At the locations where the FEH could not be avoided, the pipeline will be buried at a sufficient depth to avoid being uncovered should lateral or vertical migration of the stream occur in the future. In accordance with the requirements of 10 V.S.A § 6086, the pipeline route and the approved construction methods have been designed to ensure that the project will maintain the natural condition of the subject streams and will not endanger the health, safety, or welfare of the public or of adjoining landowners.

Attachments

Stream Crossing Index Map (dated June 25, 2013)

Summary Table - Stream Crossings for Alternative 5B (dated June 25, 2013)

Summary Table - Stream Crossings with Watersheds > 1.0 square mile (dated June 25, 2013)

Fluvial Erosion Hazard Map Series (dated June 25, 2013)

NOTES:

- USE DIVERSION FLUME STREAM CROSSING ON WATER COURSES WITH LIMITED STREAM FLOW TO PREVENT SEDIMENTATION AND INTERRUPTION OF STREAM FLOW DURING CONSTRUCTION. THIS METHOD IS APPROPRIATE IN LOCATIONS WHERE FISH PASSAGE IS A CONCERN.
- SCHEDULE CONSTRUCTION DURING LOW FLOW PERIOD, IF POSSIBLE.
- THIS DETAIL REPRESENTS ONE POSSIBLE CONFIGURATION OF CONSTRUCTION ELEMENTS WITHIN THE TEMPORARY AND PERMANENT ROW. ALTERNATE CONFIGURATIONS OF CONSTRUCTION ELEMENTS BETWEEN THE UPSTREAM AND DOWNSTREAM DIVERSION STRUCTURES ARE ALLOWABLE SO LONG AS APPROPRIATE MEASURES ARE MAINTAINED TO PROTECT WATER QUALITY.
- SET UP STEEL OR HDPE PIPE AS SHOWN, OR USE PRACTICAL ALTERNATIVES. PIPE (OR PIPES) MUST BE SIZED TO HAVE TWICE THE CAPACITY OF ANTICIPATED FLOW. DEPENDING ON STREAM FLOW, DIG SUMP HOLE TO CONCENTRATE WATER AT INTAKE.
- INSTALL UPSTREAM DAM COMPOSED OF SANDBAGS, METAL PLATING OR A COMBINATION OF BOTH. INSTALL DOWNSTREAM DAM, IF REQUIRED, TO KEEP STREAM BED DRY.
- AFTER DAMS ARE IN PLACE, IT MAY BE NECESSARY TO USE A SUMP PUMP AND DEWATERING FILTER BAG TO KEEP WORK AREA DRY.
- ALL MECHANIZED EQUIPMENT TO PERFORM WORK FROM ADJACENT TOP OF BANK AREAS. MAT STREAM IF WORK TO OCCUR IN STREAM CHANNEL.
- EXCAVATE TRENCH AND LOWER IN PIPE UNDER DIVERSION FLUME. MOVE FLUME AS REQUIRED OR DISCONNECT IF TEMPORARY FLOW BLOCKAGE IS ACCEPTABLE. BACKFILL TRENCH.
- DISMANTLE DOWNSTREAM DAM, THEN UPSTREAM DAM.
- RESTORE DISTURBED CHANNEL, STREAM BANKS AND APPROACHES FOR A MINIMUM DISTANCE OF AT LEAST 50 FT. FROM THE STREAM EDGES AND PERMANENTLY STABILIZE WITHIN 1 DAY OF INITIAL RESTORATION. REFER TO THE STREAMBANK RESTORATION DETAIL FOR RESTORATION REQUIREMENTS.

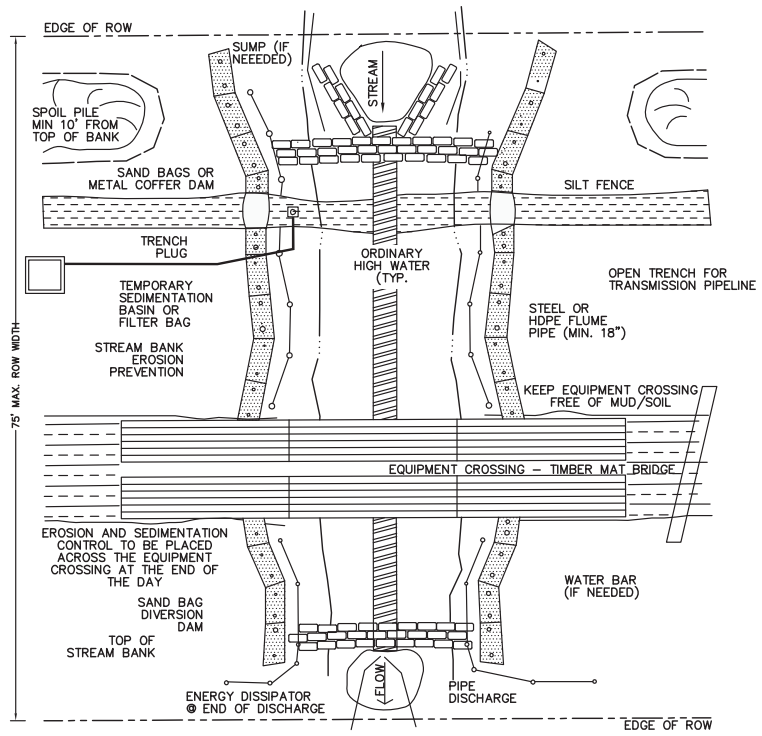

NOTES:

- USE DAM AND PUMP METHOD ON WATER COURSES WITH LIMITED STREAM FLOW TO PREVENT SEDIMENTATION AND INTERRUPTION OF STREAM FLOW DURING CONSTRUCTION.
- SCHEDULE CONSTRUCTION DURING LOW FLOW PERIOD, IF POSSIBLE.
- THIS DETAIL REPRESENTS ONE POSSIBLE CONFIGURATION OF CONSTRUCTION ELEMENTS WITHIN THE TEMPORARY AND PERMANENT ROW. ALTERNATE CONFIGURATIONS OF CONSTRUCTION ELEMENTS BETWEEN THE UPSTREAM AND DOWNSTREAM DIVERSION STRUCTURES ARE ALLOWABLE SO LONG AS APPROPRIATE MEASURES ARE MAINTAINED TO PROTECT WATER QUALITY.
- SET UP PUMP AND HOSE AS SHOWN, OR USE PRACTICAL ALTERNATIVES. PUMP SHOULD HAVE TWICE THE PUMPING CAPACITY OF ANTICIPATED FLOW. HAVE STANDBY PUMP ON SITE. DEPENDING ON STREAM FLOW, DIG SUMP HOLE TO CONCENTRATE WATER AT INTAKE.
- USE TEMPORARY SEDIMENTATION BASIN OR FILTER BAG PRIOR TO DISCHARGING WATER BACK TO STREAM.
- INSTALL UPSTREAM DAM COMPOSED OF SANDBAGS, METAL PLATING OR A COMBINATION OF BOTH. INSTALL DOWNSTREAM DAM, IF REQUIRED, TO KEEP STREAM BED DRY.
- AFTER DAMS ARE IN PLACE, IT MAY BE NECESSARY TO USE ADDITIONAL PUMPS TO HANDLE STREAM FLOW.
- EXCAVATE TRENCH AND LOWER IN PIPE UNDER HOSE. BACKFILL TRENCH.
- ALL MECHANIZED EQUIPMENT TO PERFORM WORK FROM TEMPORARY BRIDGE OR ADJACENT TOP OF BANK AREAS. USE TIMBER MATS IS TO OCCUR IN STREAM CHANNEL.
- DISMANTLE DOWNSTREAM DAM, THEN UPSTREAM DAM.
- RESTORE DISTURBED CHANNEL, STREAM BANKS AND APPROACHES FOR A MINIMUM DISTANCE OF AT LEAST 50 FT. FROM THE STREAM EDGES AND PERMANENTLY STABILIZE WITHIN 1 DAY OF INITIAL RESTORATION. REFER TO THE STREAMBANK RESTORATION DETAIL FOR RESTORATION REQUIREMENTS.

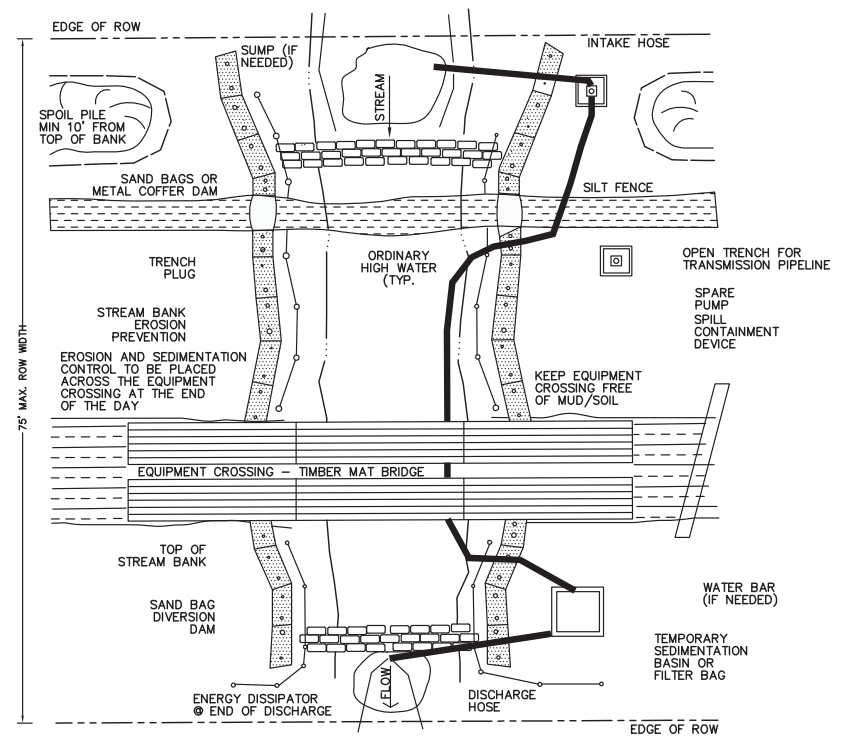

1 Diversion Flume Stream Crossing

N.T.S. Source: VHB 12/12 LD.

2 Open Trench Stream Crossing - Dam and Pump Around

N.T.S. Source: VHB 12/12 LD.

MILEPOST	RESOURCE NAME	RESOURCE AREA WIDTH (A)	HDD LENGTH (C)	DEPTH OF RESOURCE AREA (D)	ELEV. BELOW RESOURCE (E)	ENTRY ELEV. (F)	EXIT ELEV. (G)
28.2	VT-AD-1560 VT-AD-1561	300	775	400	< 393	396	396
28.57	VT-AD-1562	200	375	406	< 399	412	412
33.25	VT-AD-446	230	700	438	< 431	436	446
33.72	VT-AD-793	320	980	454	< 447	456	452
35.77	VT-AD-806	160	950	310	< 303	323	323
36.0	VT-AD-808 (1), (2)	320	520	350	< 346	346	350

MILEPOST	WETLAND ID	WETLAND WIDTH (A)	BUFFER WIDTH (B)	HDD LENGTH (C)	UNCON. MATERIAL ELEV. (D)	CONSOL. MATERIAL ELEV. (E)	ENTRY ELEV. (F)	EXIT ELEV. (G)
22.1	2012-CM-84 2012-PW-85	1,110	1,520	1,600	398	< 391	424	404
27.3	2012-PW-67 RTE-PS-045	2,300	2,450	2,270	358	< 356	< 376	< 400

MILEPOST	STREAM NAME	CHANNEL WIDTH (A)	FEH WIDTH (B)	HDD LENGTH (C)	CHANNEL ELEV. (D)	ELEV. BELOW CHANNEL (E)	ENTRY ELEV. (F)	EXIT ELEV. (G)
0.99	INDIAN BROOK	4	100	1,150	208 ¹	< 198	< 208	< 208
1.52	INDIAN BROOK	15	125	1,530	188 ²	< 178	< 188	< 188
6.75	WINOOSKI RIVER (SECTION 10 WATERS)	320	N/A (1,195)	900	263 ³	< 238	< 275	< 275
19.47	LAPLATTE RIVER	30	360	640	317 ²	< 307	< 317	< 317
22.86	LEWIS CREEK	80	435	2,500	310 ¹	< 300	< 310	< 310
35.85	UNNAMED TRIB. TO LITTLE OTTER CREEK	4	640	1,010	303 ²	< 293	< 303	< 303
39.30	NEW HAVEN RIVER	120	785	530	245 ²	< 235	< 245	< 245

1. CHANNEL ELEVATION BASED ON CONTOURS SHOWN ON EPSC PLAN PROVIDED BY CHA, INC. DATED 02/28/2013 AND NOT ASSESSED IN THE FIELD BY VHB.
2. CHANNEL ELEVATION BASED ON CONTOURS SHOWN ON EPSC PLAN PROVIDED BY CHA, INC. DATED 02/28/2013 AND MODIFIED BASED ON FIELD ASSESSMENT BY VHB.
3. CHANNEL ELEVATION BASED ON BATHYMETRIC SURVEY PROVIDED BY COLER & COLANTONIO DATED 12/12/2012 AND NOT ASSESSED IN THE FIELD BY VHB.

MILEPOST	STREAM NAME	CHANNEL WIDTH (A)	FEH WIDTH (B)	CHANNEL ELEV. (C)	ELEV. BELOW CHANNEL (D)	ENTRY ELEV. (E)	EXIT ELEV. (F)
3.62	INDIAN BROOK	7	N/A (185)	430 ²	< 420	< 430	< 430
6.60	ALDER BROOK	35	N/A (150)	281 ¹	< 274	< 281	< 281
10.32	ALLEN BROOK	35	360	376 ²	< 366	< 376	< 376
13.79	SUCKER BROOK	15	120	367 ²	< 360	< 367	< 367
18.93	UNNAMED TRIBUTARY TO LAPLATTE RIVER	4	N/A (310)	328 ¹	< 321	< 328	< 328
19.94	UNNAMED TRIBUTARY TO LAPLATTE RIVER	4	125	330 ²	< 323	< 330	< 330
24.52	UNNAMED TRIBUTARY TO LEWIS CREEK	8	N/A (200)	407 ³	< 400	< 407	< 407
29.11	UNNAMED TRIBUTARY TO LITTLE OTTER CREEK	8	N/A (400)	362 ²	< 355	< 362	< 362
32.94	UNNAMED TRIBUTARY TO LITTLE OTTER CREEK	4	200	267 ²	< 260	< 267	< 267
32.30	LITTLE OTTER CREEK	35	240	267 ¹	< 260	< 267	< 267

1. CHANNEL ELEVATION BASED ON CONTOURS SHOWN ON EPSC PLAN PROVIDED BY CHA, INC. DATED 02/28/2013 AND MODIFIED BASED ON FIELD ASSESSMENT BY VHB.
2. CHANNEL ELEVATION BASED ON CONTOURS SHOWN ON EPSC PLAN PROVIDED BY CHA, INC. DATED 02/28/2013 AND NOT ASSESSED IN THE FIELD BY VHB.
3. CHANNEL ELEVATION BASED ON TOPOGRAPHIC INFORMATION FROM GOOGLE EARTH AND NOT ASSESSED IN THE FIELD BY VHB.

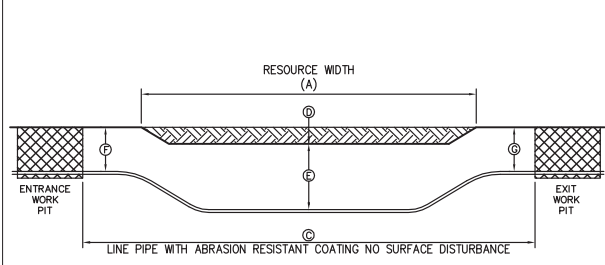

- Notes:
- THIS CONFIGURATION IS FOR HORIZONTAL DIRECTIONAL DRILL OF UPLAND NATURAL AND CULTURAL (ARCHAEOLOGICAL) RESOURCE SITES AS SHOWN ON PROJECT PLANS. SEE ALIGNMENT SHEETS FOR LOCATIONS OF THIS CONFIGURATION.
 - MINIMUM SEPARATION BETWEEN THE TOP OF PIPELINE AND THE CHANNEL RESOURCE BOTTOM (DIMENSION E) MUST BE AT LEAST 2 FEET.
 - ELEVATIONS PROVIDED ARE BASED ON APPROXIMATE NAVD 88 DATUM AND MUST BE FIELD VERIFIED PRIOR TO INSTALLATION OF PIPELINE.

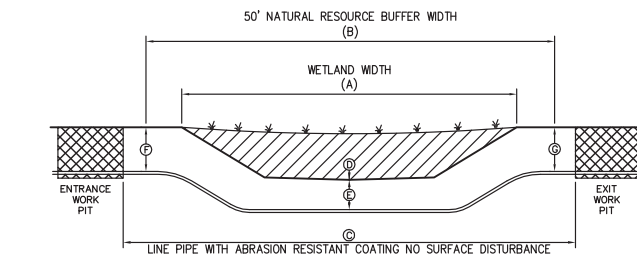

- Notes:
- THIS CONFIGURATION IS FOR HORIZONTAL DIRECTIONAL DRILL OF WETLAND CROSSINGS AS SHOWN ON PROJECT PLANS. SEE ALIGNMENT SHEETS FOR LOCATIONS OF THIS CONFIGURATION.
 - TOP OF PIPELINE MUST BE BELOW THE DEPTH OF PEAT OR OTHER UNCONSOLIDATED ORGANIC MATERIALS (DIMENSION D) THROUGHOUT THE LENGTH OF THE DRILL.
 - MINIMUM SEPARATION BETWEEN THE UNCONSOLIDATED MATERIAL AND THE TOP OF PIPELINE (DIMENSION E) MUST BE AT LEAST 2 FEET.
 - ELEVATIONS PROVIDED ARE BASED ON APPROXIMATE NAVD 88 DATUM AND MUST BE FIELD VERIFIED PRIOR TO INSTALLATION OF PIPELINE.

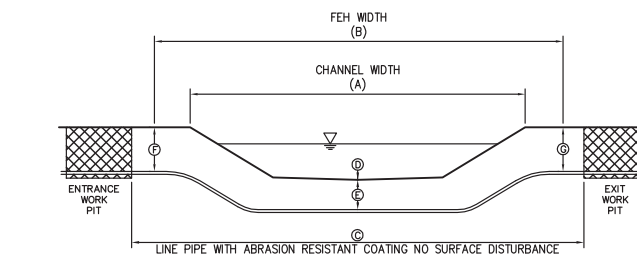

- Notes:
- THIS CONFIGURATION IS FOR HORIZONTAL DIRECTIONAL DRILL OF STREAM CROSSINGS AS SHOWN ON PROJECT PLANS. SEE ALIGNMENT SHEETS FOR LOCATIONS OF THIS CONFIGURATION.
 - TOP OF PIPELINE MUST BE AT LEAST AS DEEP AS THE CHANNEL BOTTOM (DIMENSION D) THROUGHOUT THE FLUVIAL EROSION HAZARD (FEH) CORRIDOR.
 - MINIMUM SEPARATION BETWEEN THE TOP OF PIPELINE AND THE CHANNEL BOTTOM (DIMENSION E) MUST BE AT LEAST 7 FEET.
 - ELEVATIONS PROVIDED ARE BASED ON APPROXIMATE NAVD 88 DATUM AND MUST BE FIELD VERIFIED PRIOR TO INSTALLATION OF PIPELINE.
 - FEH CORRIDOR IS LISTED AS NOT APPLICABLE (N/A) WHERE THE STREAM CROSSES OR IS ADJACENT TO AN EXISTING ROADWAY OR OTHER INFRASTRUCTURE THAT RESULTS IN RIVER MANAGEMENT CONSTRAINTS AT THAT LOCATION. FEH CORRIDOR WIDTHS AT THESE LOCATIONS ARE SHOWN FOR INFORMATION PURPOSES ONLY.

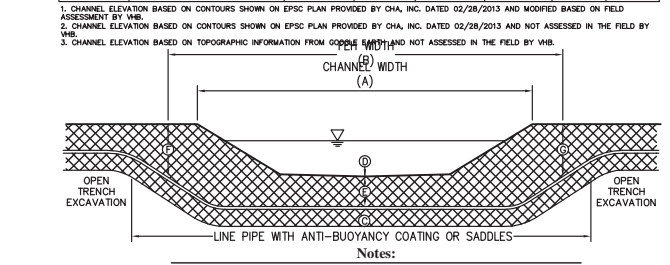

- Notes:
- THIS CONFIGURATION IS FOR OPEN TRENCH EXCAVATION OF STREAM CROSSINGS AS SHOWN ON PROJECT PLANS. SEE ALIGNMENT SHEETS FOR LOCATIONS OF THIS CONFIGURATION.
 - TOP OF PIPELINE MUST BE AT LEAST AS DEEP AS THE CHANNEL BOTTOM (DIMENSION D) THROUGHOUT THE FLUVIAL EROSION HAZARD (FEH) CORRIDOR.
 - MINIMUM SEPARATION BETWEEN THE TOP OF PIPELINE AND THE CHANNEL BOTTOM (DIMENSION E) MUST BE AT LEAST 7 FEET.
 - ELEVATIONS PROVIDED ARE BASED ON APPROXIMATE NAVD 88 DATUM AND MUST BE FIELD VERIFIED PRIOR TO INSTALLATION OF PIPELINE.
 - FEH CORRIDOR IS LISTED AS NOT APPLICABLE (N/A) WHERE THE STREAM CROSSES OR IS ADJACENT TO AN EXISTING ROADWAY OR OTHER INFRASTRUCTURE THAT RESULTS IN RIVER MANAGEMENT CONSTRAINTS AT THAT LOCATION. FEH CORRIDOR WIDTHS AT THESE LOCATIONS ARE SHOWN FOR INFORMATION PURPOSES ONLY.
 - RESTORE DISTURBED CHANNEL, STREAM BANKS, AND APPROACHES FOLLOWING PIPELINE INSTALLATION PER EPSC PLAN.

3 Horizontal Directional Drill (HDD) Upland Natural / Cultural Resource - Typical Section

N.T.S. Source: VHB 04/13

4 Horizontal Directional Drill (HDD) Wetland Crossing - Typical Section

N.T.S. Source: VHB 04/13

5 Horizontal Directional Drill (HDD) Stream Crossing - Typical Section

N.T.S. Source: VHB 04/13

6 Open Trench Stream Crossing - Typical Section

N.T.S. Source: VHB 04/13

DWG. NO.	REFERENCE DWG.	REV	DSN	CK	DESCRIPTION	INITIALS	DATE	INITIALS	DATE	YEAR: 2013	W.O.	SCALE: NOTED	DWG. ANGP-T-G-020	REV. 0
		0	MDF	SAB	ISSUED FOR CONSTRUCTION									

	BID	CONSTRUCTION
ENVIRONMENTAL	JLS 06/28/13	
DRAFTING DESIGNER	GIL 06/28/13	
DRAFTING SUPERVISOR	BZD 06/28/13	
DESIGN ENGINEER	MDF 06/28/13	
DESIGN MANAGER	SAB 06/28/13	

VERMONT GAS
PROPOSED 12" PIPELINE
ADDISON NATURAL GAS PROJECT
CONSTRUCTION DETAILS
LOC. CHITTENDEN & ADDISON COUNTIES

36 Cortage Park Circle, Suite 321, 326, 328, 338
Plymouth, MA 02260
Main: (781) 862-7700 www.chiacompanies.com

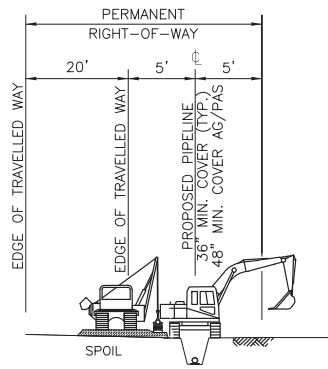

CONSTRUCTION TYPE 4G
NOT TO SCALE

- NOTE:**
1. THIS CONFIGURATION IS FOR ROADSIDE CONSTRUCTION SPACE AND DOES NOT DEPICT ADDITIONAL TEMP. WORKSPACE.
 2. ADDITIONAL TEMP. WORKSPACE HAS BEEN TYPICALLY INCORPORATED ON THE ALIGNMENT SHEETS FOR AREAS SUCH AS ROAD, RIVER/STREAM/WATERBODY, AND ARCHEOLOGICAL SITE CROSSINGS WHERE HORIZONTAL DIRECTIONAL DRILL CONSTRUCTION HAS BEEN PROPOSED.
 3. FOR AREAS DESIGNATED AS PRIME AGRICULTURAL SOILS (PAS) IN THE SOIL TYPE BAND OF THE EPSC SHEETS, SEE "CONSTRUCTION WITHIN PRIME AGRICULTURAL SOILS (PAS) AREAS" FOR SOIL SEGREGATION AND ASSOCIATED CONSTRUCTION PROCEDURES.
 4. SEE ALIGNMENT SHEETS FOR LOCATIONS OF THIS CONFIGURATION.

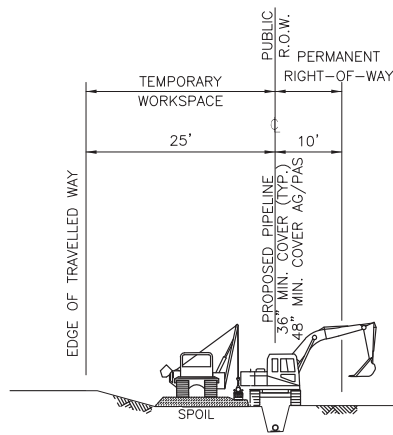

CONSTRUCTION TYPE 4H
NOT TO SCALE

- NOTE:**
1. THIS CONFIGURATION IS FOR ROADSIDE CONSTRUCTION SPACE AND DOES NOT DEPICT ADDITIONAL TEMP. WORKSPACE.
 2. ADDITIONAL TEMP. WORKSPACE HAS BEEN TYPICALLY INCORPORATED ON THE ALIGNMENT SHEETS FOR AREAS SUCH AS ROAD, RIVER/STREAM/WATERBODY, AND ARCHEOLOGICAL SITE CROSSINGS WHERE HORIZONTAL DIRECTIONAL DRILL CONSTRUCTION HAS BEEN PROPOSED.
 3. FOR AREAS DESIGNATED AS PRIME AGRICULTURAL SOILS (PAS) IN THE SOIL TYPE BAND OF THE EPSC SHEETS, SEE "CONSTRUCTION WITHIN PRIME AGRICULTURAL SOILS (PAS) AREAS" FOR SOIL SEGREGATION AND ASSOCIATED CONSTRUCTION PROCEDURES.
 4. SEE ALIGNMENT SHEETS FOR LOCATIONS OF THIS CONFIGURATION.

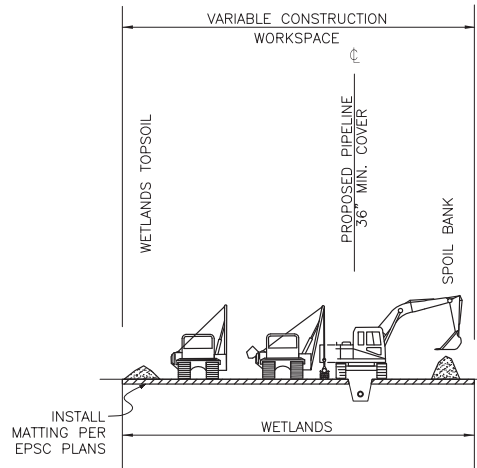

CONSTRUCTION TYPE W
NOT TO SCALE

- NOTE:**
1. THIS CONFIGURATION IS FOR VARIABLE CONSTRUCTION SPACE IN WETLANDS AND DOES NOT DEPICT ADDITIONAL TEMP. WORKSPACE.
 2. ADDITIONAL TEMP. WORKSPACE HAS BEEN TYPICALLY INCORPORATED ON THE ALIGNMENT & EPSC SHEETS FOR AREAS SUCH AS ROAD, RIVER/STREAM/WATERBODY, AND ARCHEOLOGICAL SITE CROSSINGS WHERE HORIZONTAL DIRECTIONAL DRILL CONSTRUCTION HAS BEEN PROPOSED.
 3. SEE ALIGNMENT & EPSC SHEETS FOR LOCATIONS OF THIS CONFIGURATION.
 4. WHEN BACK-PILING, SOILS SHALL BE REPLACED IN ORDER THEY WERE EXCAVATED, WITH TOPSOIL AS UPPER LAYER FILL AND COMPACT SUBSOIL TO DEPTH OF ADJACENT NATIVE SUBSOIL/TOPSOIL INTERFACE. REPLACE TOPSOIL AS UPPER LAYER AND BLEND TO EXISTING GRADE OF UNDISTURBED SOILS. DISPOSE OF EXCESS SUBSOIL AT SUITABLE LOCATION AS APPROVED BY THE OSPC.
 5. SEE EPSC PLAN "ADDITIONAL ENVIRONMENTAL NOTES" FOR ADDITIONAL INSTRUCTIONS RELATED TO CONSTRUCTION IN WETLANDS, INCLUDING FINAL STABILIZATION NOTES.

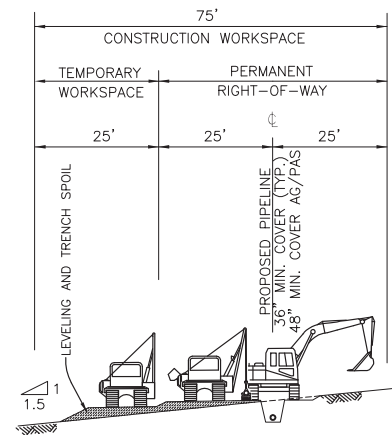

CONSTRUCTION TYPE 6A
NOT TO SCALE

- NOTE:**
1. THIS CONFIGURATION IS FOR SIDE HILL SLOPE CONSTRUCTION AND DOES NOT DEPICT ADDITIONAL TEMP. WORKSPACE.
 2. ADDITIONAL TEMP. WORKSPACE HAS BEEN TYPICALLY INCORPORATED ON THE ALIGNMENT SHEETS FOR AREAS SUCH AS ROAD, RIVER/STREAM/WATERBODY, AND ARCHEOLOGICAL SITE CROSSINGS WHERE HORIZONTAL DIRECTIONAL DRILL CONSTRUCTION HAS BEEN PROPOSED.
 3. FOR AREAS DESIGNATED AS PRIME AGRICULTURAL SOILS (PAS) IN THE SOIL TYPE BAND OF THE EPSC SHEETS, SEE "CONSTRUCTION WITHIN PRIME AGRICULTURAL SOILS (PAS) AREAS" FOR SOIL SEGREGATION AND ASSOCIATED CONSTRUCTION PROCEDURES.
 4. SEE ALIGNMENT SHEETS FOR LOCATIONS OF THIS CONFIGURATION.

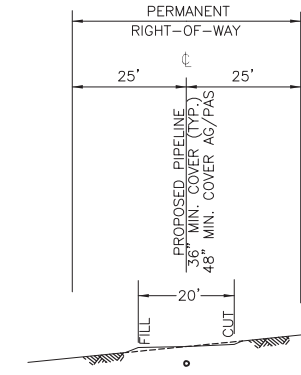

CONSTRUCTION TYPE 6B
NOT TO SCALE

- NOTE:**
1. THIS CONFIGURATION IS FOR SIDE HILL SLOPE CONSTRUCTION AND DOES NOT DEPICT ADDITIONAL TEMP. WORKSPACE.
 2. ADDITIONAL TEMP. WORKSPACE HAS BEEN TYPICALLY INCORPORATED ON THE ALIGNMENT SHEETS FOR AREAS SUCH AS ROAD, RIVER/STREAM/WATERBODY, AND ARCHEOLOGICAL SITE CROSSINGS WHERE HORIZONTAL DIRECTIONAL DRILL CONSTRUCTION HAS BEEN PROPOSED.

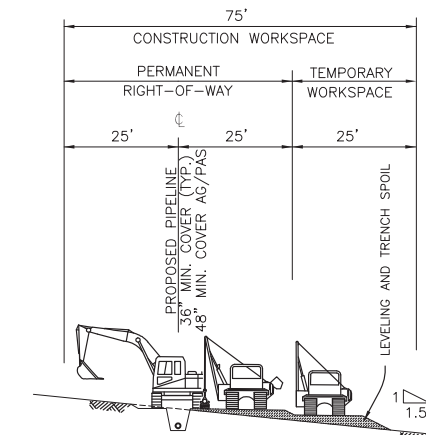

CONSTRUCTION TYPE 6C
NOT TO SCALE

- NOTE:**
1. THIS CONFIGURATION IS FOR SIDE HILL SLOPE CONSTRUCTION AND DOES NOT DEPICT ADDITIONAL TEMP. WORKSPACE.
 2. ADDITIONAL TEMP. WORKSPACE HAS BEEN TYPICALLY INCORPORATED ON THE ALIGNMENT SHEETS FOR AREAS SUCH AS ROAD, RIVER/STREAM/WATERBODY, AND ARCHEOLOGICAL SITE CROSSINGS WHERE HORIZONTAL DIRECTIONAL DRILL CONSTRUCTION HAS BEEN PROPOSED.
 3. FOR AREAS DESIGNATED AS PRIME AGRICULTURAL SOILS (PAS) IN THE SOIL TYPE BAND OF THE EPSC SHEETS, SEE "CONSTRUCTION WITHIN PRIME AGRICULTURAL SOILS (PAS) AREAS" FOR SOIL SEGREGATION AND ASSOCIATED CONSTRUCTION PROCEDURES.
 4. SEE ALIGNMENT SHEETS FOR LOCATIONS OF THIS CONFIGURATION.

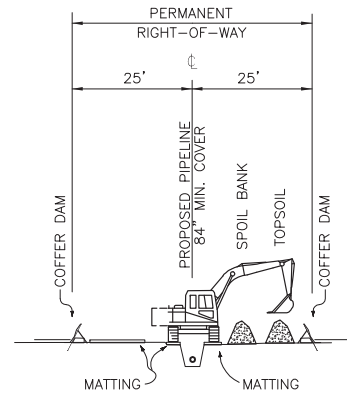

CONSTRUCTION TYPE 7
NOT TO SCALE

- NOTE:**
1. THIS CONFIGURATION IS FOR STREAM CROSSING AND DOES NOT DEPICT ADDITIONAL TEMP. WORKSPACE.
 2. ADDITIONAL TEMP. WORKSPACE HAS BEEN TYPICALLY INCORPORATED ON THE ALIGNMENT SHEETS FOR AREAS SUCH AS ROAD, RIVER/STREAM/WATERBODY, AND ARCHEOLOGICAL SITE CROSSINGS WHERE HORIZONTAL DIRECTIONAL DRILL CONSTRUCTION HAS BEEN PROPOSED.
 3. FOR AREAS DESIGNATED AS PRIME AGRICULTURAL SOILS (PAS) IN THE SOIL TYPE BAND OF THE EPSC SHEETS, SEE "CONSTRUCTION WITHIN PRIME AGRICULTURAL SOILS (PAS) AREAS" FOR SOIL SEGREGATION AND ASSOCIATED CONSTRUCTION PROCEDURES.
 4. SEE ALIGNMENT SHEETS FOR LOCATIONS OF THIS CONFIGURATION.

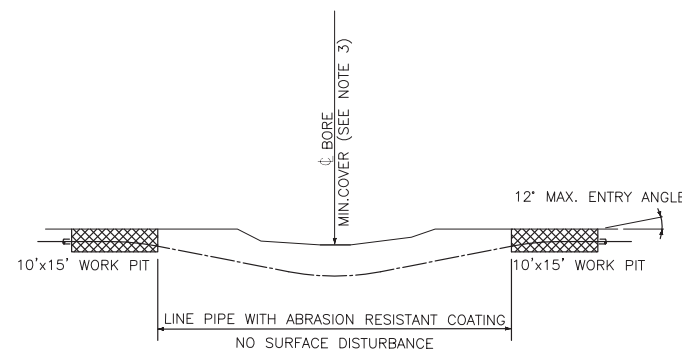

CONSTRUCTION TYPE 8
NOT TO SCALE

- NOTE:**
1. THIS CONFIGURATION IS FOR OPTIONAL STREAM OR ROAD CROSSING HORIZONTAL DIRECTIONAL DRILL.
 2. SEE ALIGNMENT SHEETS FOR LOCATIONS OF THIS CONFIGURATION.
 3. SEE TABLE ON ANGP-T-G-020 FOR COVER REQUIREMENTS.

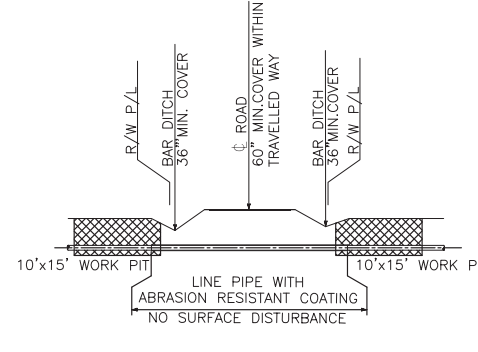

CONSTRUCTION TYPE 9
NOT TO SCALE

- NOTE:**
1. THIS CONFIGURATION IS FOR UNCASSED ROAD CROSSING CONSTRUCTION.
 2. SEE ALIGNMENT SHEETS FOR LOCATIONS OF THIS CONFIGURATION AND MATERIAL SPECIFICATIONS.
 3. SEE SITE SPECIFIC SOIL BORING DETAILS FOR ADDITIONAL INFORMATION.

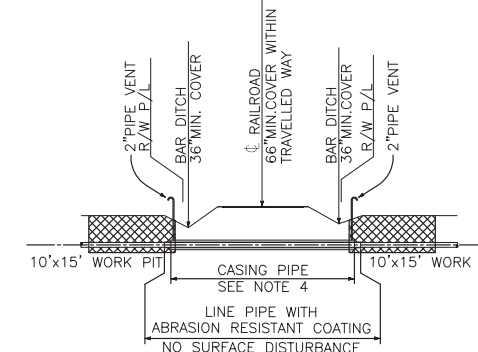

CONSTRUCTION TYPE 10
NOT TO SCALE

- NOTE:**
1. THIS CONFIGURATION IS FOR CASSED ROAD AND RAILROAD CROSSING CONSTRUCTION.
 2. SEE ALIGNMENT SHEETS FOR LOCATIONS OF THIS CONFIGURATION AND MATERIAL SPECIFICATIONS.
 3. SEE SITE SPECIFIC SOIL BORING DETAILS FOR ADDITIONAL INFORMATION.
 4. ANNULUS FILLED WITH DIELECTRIC MATERIAL PER VT GAS SPECIFICATIONS FOR ABRASION RESISTANT COATED CARRYING PIPE ONLY. DIELECTRIC MATERIAL SHALL NOT FILL THE ANNULUS SPACE WHERE CONCRETE COATED CARRYING PIPE IS SPECIFIED.

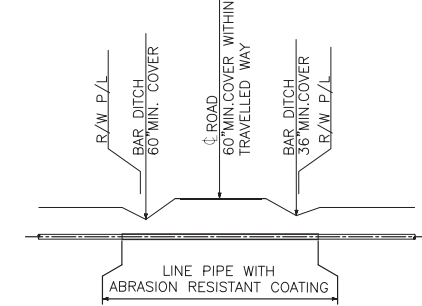

CONSTRUCTION TYPE 11
NOT TO SCALE

- NOTE:**
1. THIS CONFIGURATION IS FOR OPEN CUT ROAD CROSSING CONSTRUCTION.
 2. SEE ALIGNMENT SHEETS FOR LOCATIONS OF THIS CONFIGURATION AND MATERIAL SPECIFICATIONS.
 3. SEE SITE SPECIFIC SOIL BORING DETAILS FOR ADDITIONAL INFORMATION.
 4. COMPACTION AND RESTORATION TO TOWN AND VT GAS SPECIFICATIONS.

- NOTE:**
1. CONSTRUCTION TYPE 5 NOT USED.

DWG. NO.	REFERENCE DWG.	0	MDF	SAB	ISSUED FOR CONSTRUCTION	ENVIRONMENTAL	JLS	06/28/13	CONSTRUCTION	VERMONT GAS PROPOSED 12" PIPELINE ADDISON NATURAL GAS PROJECT CONSTRUCTION CONFIGURATION DETAILS		
		REV	DSN	CK	DESCRIPTION	DRAFTING DESIGNER	GIL	06/28/13	INITIALS	YEAR: 2013		
						DRAFTING SUPERVISOR	BZD	06/28/13	INITIALS	DATE		
						DESIGN ENGINEER	MDF	06/28/13				
						DESIGN MANAGER	SAB	06/28/13				

VHB Vanasse Hangen Brustlin, Inc.

VERMONT GAS
PROPOSED 12" PIPELINE
ADDISON NATURAL GAS PROJECT
CONSTRUCTION CONFIGURATION DETAILS

LOC. CHITTENDEN & ADDISON COUNTIES

DWG. ANGP-T-G-006 REV. 0

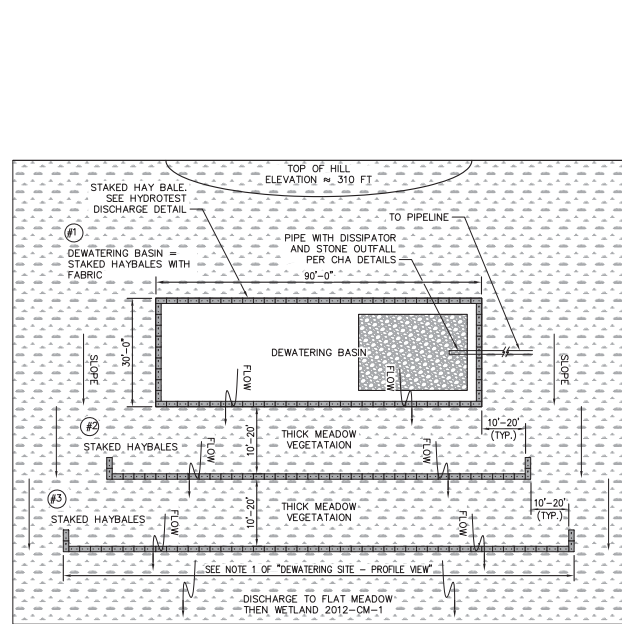

1 Dewatering Site - Plan View 09/13
N.T.S. Source: VHB

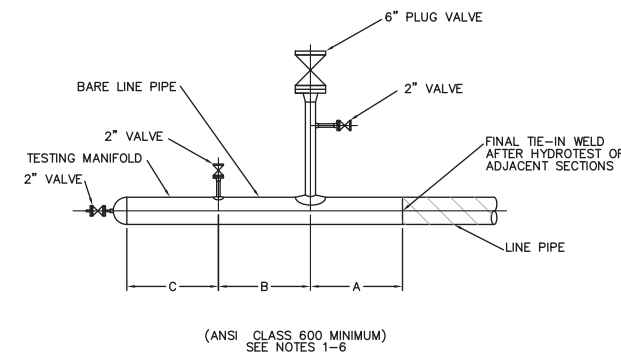

- 2 Typical Hydrastatic Test Manifold** 12/12
N.T.S. Source: CHA
- Notes:
- DIMENSIONS A, B & C ARE DEPENDENT ON PIPE DIAMETER & PIG LENGTH AND ARE TO BE DETERMINED BY CONTRACTOR.
 - FOR MANIFOLD TEST LOCATIONS & DISCHARGE LOCATIONS REFER TO EM&CP DRAWINGS.
 - TEST WATER SHALL BE TRANSFERRED BY PUMPING FROM ONE TEST SECTION TO THE NEXT ADJACENT TEST SECTION THROUGH THE 6" PIPE BRANCH AND MAKE-UP PIPING BETWEEN TEST SECTIONS. USE OF "HARD PIPING" & UNIONS IS RECOMMENDED.
 - FINAL TIE-IN WELD(S) BETWEEN TEST SECTIONS TO BE 100% RADIOGRAPHED.
 - TAP AND BRANCH SIZES AND VALVES FOR MANIFOLD ARE CONCEPTUAL AND SHALL BE DESIGNED BY CONTRACTOR TO BE COMPATIBLE WITH TEST EQUIPMENT AND PIPING.

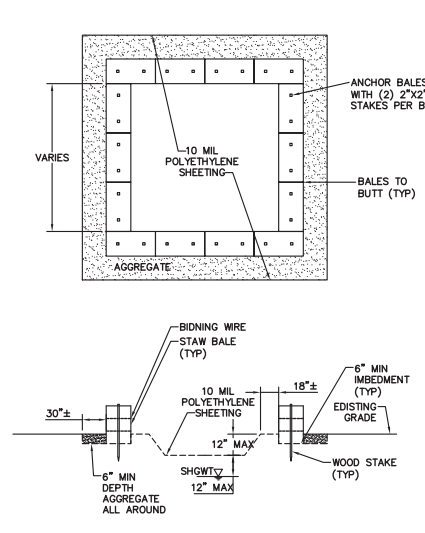

3 Concrete Washout Area 12/12
N.T.S. Source: VHB

MILEPOST	STREAM NAME	CHANNEL WIDTH (A)	FEH WIDTH (B)	HDD LENGTH (C)	CHANNEL ELEV. (D)	ELEV. BELOW CHANNEL (E)	ENTRY ELEV. (F)	EXIT ELEV. (G)
0.99	INDIAN BROOK	4	100	2,339	208'	< 198	< 208	< 208
1.52	INDIAN BROOK	15	125	1,530	188'	< 178	< 188	< 188
6.75	WINOOSKI RIVER (SECTION 10 WATERS)	320	N/A (1,195)	900	263'	< 238	< 275	< 275
19.47	LAPLATE RIVER	30	360	640	317'	< 307	< 317	< 317
22.86	LEWIS CREEK	80	435	2,500	310'	< 300	< 310	< 310
32.30	LITTLE OTTER CREEK	35	240	1,680	267'	< 260	< 267	< 267
35.85	UNNAMED TRIB. TO LITTLE OTTER CREEK	4	640	1,010	303'	< 293	< 303	< 303
39.30	NEW HAVEN RIVER	120	785	530	245'	< 235	< 245	< 245
DISTRIBUTION MAIN 30+00	UNNAMED TRIB TO LITTLE OTTER CREEK	8	N/A (108)	300	261'	< 254	< 261	< 261

1. CHANNEL ELEVATION BASED ON CONTOURS SHOWN ON EPSC PLAN PROVIDED BY CHA, INC. DATED 02/28/2013 AND NOT ASSESSED IN THE FIELD BY VHB.
2. CHANNEL ELEVATION BASED ON CONTOURS SHOWN ON EPSC PLAN PROVIDED BY CHA, INC. DATED 02/28/2013 AND MODIFIED BASED ON FIELD ASSESSMENT BY VHB.
3. CHANNEL ELEVATION BASED ON BATHYMETRIC SURVEY PROVIDED BY COLE & COLANTONIO DATED 12/12/2012 AND NOT ASSESSED IN THE FIELD BY VHB.

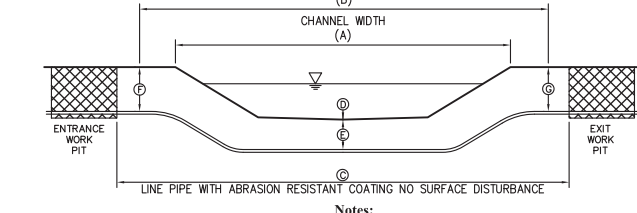

4 Horizontal Directional Drill (HDD) Stream Crossing - Typical Section 4/13
N.T.S. Source: VHB

- Notes:
- THIS CONFIGURATION IS FOR HORIZONTAL DIRECTIONAL DRILL OF STREAM CROSSINGS AS SHOWN ON PROJECT PLANS. SEE ALIGNMENT SHEETS FOR LOCATIONS OF THIS CONFIGURATION.
 - TOP OF PIPELINE MUST BE AT LEAST AS DEEP AS THE CHANNEL BOTTOM (DIMENSION D) THROUGHOUT THE FLUVIAL EROSION HAZARD (FEH) CORRIDOR.
 - MINIMUM SEPARATION BETWEEN THE TOP OF PIPELINE AND THE CHANNEL BOTTOM (DIMENSION E) MUST BE AT LEAST 7 FEET.
 - ELEVATIONS PROVIDED ARE BASED ON APPROXIMATE NAVD 88 DATUM AND MUST BE FIELD VERIFIED PRIOR TO INSTALLATION OF PIPELINE.
 - FEH CORRIDOR IS LISTED AS NOT APPLICABLE (N/A) WHERE THE STREAM CROSSES OR IS ADJACENT TO AN EXISTING ROADWAY OR OTHER INFRASTRUCTURE THAT RESULTS IN RIVER MANAGEMENT CONSTRAINTS AT THAT LOCATION. FEH CORRIDOR WIDTHS AT THESE LOCATIONS ARE SHOWN FOR INFORMATION PURPOSES ONLY.

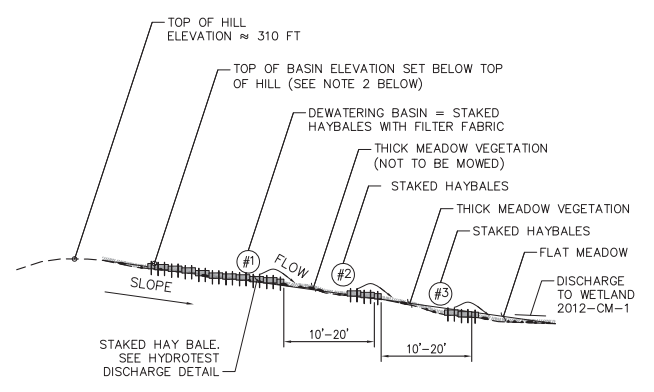

5 Dewatering Site - Profile View 09/13
N.T.S. Source: VHB

- Notes:
- THE DEWATERING SITE SHALL CONSIST OF THREE ROWS OF STAKED HAYBALES. THE TOP ROW SHALL BE ENCLOSED TO ACT AS A BASIN WITH FILTER FABRIC AND STONE OUTFALL AT THE DISCHARGE OUTLET. EACH DOWNSLOPE ROW OF HAYBALES SHALL BE CONSECUTIVELY LONGER THAN THE ROW UPSLOPE OF IT AS PER THE PLAN VIEW DETAIL. THE BOTTOM ROW IS TO EXTEND ACROSS THE ENTIRE WIDTH OF THE DENSELY VEGETATED MEADOW.
 - THE HIGHEST ELEVATION OF THE TOP ROW OF HAYBALES SHALL BE LOWER THAN THE ELEVATION AT THE TOP OF THE HILL TO ENSURE DISCHARGE DOES NOT FLOW OVER THE HILL.
 - DURING TESTING, THE CONTRACTOR SHALL HAVE ADDITIONAL STONE, HAYBALES, AND STAKES ON SITE FOR USE IF ADDITIONAL EPSC MEASURES ARE NEEDED.
 - SEE HYDROTEST DISCHARGE DETAIL FOR DEWATERING BASIN INSTALLATION SPECIFICATIONS.
 - SEE HAY BALE BARRIER DETAIL FOR STAKED HAYBALE INSTALLATION SPECIFICATIONS.
 - MEADOW IS NOT TO BE MOWED PRIOR TO USE FOR FILTERING FLOW.

PRODUCT DESCRIPTION	MATERIAL COMPOSITION	LONGEVITY (MONTHS)	SLOPE APPLICATIONS*		CHANNEL APPLICATIONS*	MINIMUM TENSILE STRENGTH ^{1,2} kN/m (lbs/ft)
			MAXIMUM GRADIENT (H:V)	C FACTOR ^{2,3}		
MULCH CONTROL NETS	MESH OR WOVEN BIODEGRADABLE NATURAL FIBER NETTING.	3	5:1	≤ 0.10	12 (0.25)	0.073 (5)
		12	5:1	≤ 0.10	12 (0.25)	0.073 (5)
		24	5:1	≤ 0.10	12 (0.25)	0.36 (25)
NETLESS ROLLED EROSION CONTROL BLANKETS	NATURAL FIBERS MECHANICALLY INTERLOCKED TOGETHER TO FORM A RECP.	3	4:1	≤ 0.10	24 (0.5)	0.073 (5)
		12	4:1	≤ 0.10	24 (0.5)	0.073 (5)
SINGLE-NET EROSION CONTROL BLANKETS	PROCESSED BIODEGRADABLE NATURAL FIBERS MECHANICALLY BOUND TOGETHER BY A SINGLE NATURAL FIBER NETTING OF PROCESSED NATURAL YARNS OR TWINES WOVEN INTO A CONTINUOUS MATRIX.	3	3:1	≤ 0.15	72 (1.5)	0.73 (50)
		12	3:1	≤ 0.15	72 (1.5)	0.73 (50)
DOUBLE-NET EROSION CONTROL BLANKETS	PROCESSED BIODEGRADABLE NATURAL FIBERS MECHANICALLY BOUND TOGETHER BETWEEN TWO NATURAL FIBER NETTING OF PROCESSED NATURAL YARNS OR TWINES WOVEN INTO A CONTINUOUS MATRIX.	3	2:1	≤ 0.20	84 (1.75)	1.09 (75)
		12	2:1	≤ 0.20	84 (1.75)	1.09 (75)
		24	1.5:1	≤ 0.25	96 (2.00)	1.45 (100)
		36	1:1	≤ 0.25	108 (2.25)	1.82 (125)

6 Specifications for Temporary RECP 04/13
N.T.S. Source: VT S+S EPSC

- * "C" FACTOR AND SHEAR STRESS FOR MULCH CONTROL NETTINGS MUST BE OBTAINED WITH NETTING USED IN CONJUNCTION WITH PRE-APPLIED MATERIAL.
1. MINIMUM AVERAGE ROLL VALUES, MACHINE DIRECTION USING EROSION CONTROL TECHNOLOGY COUNCIL (ECTC) MOD. ASTM D 5035.
2. "C" FACTOR CALCULATED AS RATIO OF SOIL LOSS FROM RECP PROTECTED SLOPE (TESTED AT SPECIFIED OR GREATER GRADIENT (H:V)) TO RATIO OF SOIL LOSS FROM UNPROTECTED (CONTROL) PLOT IN LARGE-SCALE TESTING. THESE PERFORMANCE TEST VALUES SHOULD BE SUPPORTED BY PERIODIC BENCH SCALE TESTING UNDER SIMILAR TEST CONDITIONS AND FAILURE CRITERIA USING ECTC TEST METHOD #2.
3. REQUIRED MINIMUM SHEAR STRESS RECP (UNVEGETATED) CAN SUSTAIN WITHOUT PHYSICAL DAMAGE OR EXCESS EROSION (> 12.7mm (0.5 IN) SOIL LOSS) DURING A 30-MINUTE FLOW EVENT IN LARGE-SCALE TESTING. THESE PERFORMANCE TEST VALUES SHOULD BE SUPPORTED BY PERIODIC BENCH SCALE TESTING UNDER SIMILAR TEST CONDITIONS AND FAILURE CRITERIA USING ECTC TEST METHOD #3.
4. THE PERMISSIBLE SHEAR STRESS LEVELS ESTABLISHED FOR EACH PERFORMANCE CATEGORY ARE BASED ON HISTORICAL EXPERIENCE WITH PRODUCTS CHARACTERIZED BY MANNINGS ROUGHNESS COEFFICIENTS IN THE RANGE OF 0.01 - 0.05.
5. ACCEPTABLE LARGE SCALE TESTING METHODS MAY INCLUDE ASTM D 6459, ECTC TEST METHOD #2 OR OTHER INDEPENDENT TESTING DEEMED ACCEPTABLE BY THE DEC.
6. RECOMMENDED ACCEPTABLE LARGE-SCALE TESTING PROTOCOL MAY INCLUDE ASTM D 6440, ECTC TEST METHOD #3 OR OTHER INDEPENDENT TESTING DEEMED ACCEPTABLE BY THE DEC.

TYPE	PRODUCT DESCRIPTION	MATERIAL COMPOSITION	SLOPE APPLICATIONS		CHANNEL APPLICATIONS	MINIMUM TENSILE STRENGTH ^{1,2} kN/m (lbs/ft)
			MAXIMUM GRADIENT	MAXIMUM SHEAR STRESS ^{3,4} Pa(lbs/ft ²)		
A	TURF REINFORCED MAT	NON-DEGRADABLE SYNTHETIC FIBERS, FILAMENTS, NETS, WIRE MESH AND/OR OTHER ELEMENTS, PROCESSED INTO A PERMANENT THREE-DIMENSIONAL MATRIX OF SUFFICIENT THICKNESS. TRMs, WHICH MAY BE SUPPLEMENTED WITH DEGRADABLE COMPONENTS ARE DESIGNED TO IMPART IMMEDIATE EROSION PROTECTION, ENHANCED VEGETATION ESTABLISHMENT AND PROVIDE LONG-TERM FUNCTIONALITY BY PERMANENTLY REINFORCING VEGETATION DURING AND AFTER MATURATION. NOTE: TRMs ARE TYPICALLY USED IN HYDRAULIC APPLICATIONS, SUCH AS HIGH FLOW DITCHES AND CHANNELS, STEEP SLOPES, STREAM BANKS, AND SHORELINES, WHERE EROSION FORCES MAY EXCEED THE LIMITS OF NATURAL, UNREINFORCED VEGETATION OR IN AREAS WHERE LIMITED VEGETATION ESTABLISHMENT IS ANTICIPATED.	0.5:1	288 (6.0)	1.82 (125)	
			0.5:1	384 (8.0)	2.19 (150)	
C	TURF REINFORCED MAT		0.5:1	480 (10.0)	2.55 (175)	

PERMANENT¹ - ALL CATEGORIES OF TURF REINFORCEMENT MAT (TRM) MUST HAVE A MINIMUM THICKNESS OF 6.35mm (0.25 INCHES) PER ASTM D 6525 AND U.V. STABILITY OF 80% PER ASTM D 4355 (500 HOURS EXPOSURE)

- FOR TRMS CONTAINING DEGRADABLE COMPONENTS ALL PROPERTY VALUES MUST BE OBTAINED ON THE NON-DEGRADABLE PORTION OF THE MATTING ALONE.
- MINIMUM AVERAGE ROLL VALUES, MACHINE DIRECTION ONLY FOR TENSILE STRENGTH DETERMINATION USING ASTM D 6818 (SUPERSEDES MOD. ASTM D 5035 FOR RECP'S).
- FIELD CONDITIONS WITH HIGH LOADING AND/OR HIGH SURVIVABILITY REQUIREMENTS MAY WARRANT THE USE OF A TRM WITH A TENSILE STRENGTH OF 44 kN/m(3,000 lb/ft) OR GREATER.
- REQUIRED MINIMUM SHEAR STRESS TRM (FULLY VEGETATED) CAN SUSTAIN WITHOUT PHYSICAL DAMAGE OR EXCESS EROSION (>12.7mm (0.5 IN) SOIL LOSS) DURING A 30-MINUTE FLOW EVENT IN LARGE SCALE TESTING. THESE PERFORMANCE TEST VALUES SHOULD BE SUPPORTED BY PERIODIC BENCH SCALE TESTING UNDER SIMILAR TEST CONDITIONS AND FAILURE CRITERIA USING ECTC TEST METHOD #3.
- ACCEPTABLE LARGE-SCALE TESTING PROTOCOL MAY INCLUDE ASTM D 6460 ECTC TEST METHOD #3 OR OTHER INDEPENDENT TESTING DEEMED ACCEPTABLE BY THE DEC.

7 Specifications for Permanent RECP 04/13
N.T.S. Source: VT S+S EPSC

MILEPOST	STREAM NAME	CHANNEL WIDTH (A)	FEH WIDTH (B)	CHANNEL ELEV. (C)	ELEV. BELOW CHANNEL (D)	ENTRY ELEV. (E)	EXIT ELEV. (F)
3.62	INDIAN BROOK	7	N/A (185)	430'	< 420	< 430	< 430
6.60	ALDER BROOK	35	N/A (150)	281'	< 274	< 281	< 281
10.32	ALLEN BROOK	15	360	376'	< 366	< 376	< 376
13.79	SUCKER BROOK	15	120	371'	< 364	< 371	< 371
18.93	UNNAMED TRIBUTARY TO LITTLE OTTER RIVER	4	N/A (310)	328'	< 321	< 328	< 328
20.45	UNNAMED TRIBUTARY TO LITTLE OTTER RIVER	4	185	364'	< 357	< 364	< 364
24.40	UNNAMED TRIBUTARY TO LEWIS CREEK	6	106	437'	< 430	< 437	< 437
29.11	UNNAMED TRIBUTARY TO LITTLE OTTER CREEK	8	N/A (400)	364'	< 357	< 364	< 364
30.94	UNNAMED TRIBUTARY TO LITTLE OTTER CREEK	4	200	267'	< 260	< 267	< 267

1. CHANNEL ELEVATION BASED ON CONTOURS SHOWN ON EPSC PLAN PROVIDED BY CHA, INC. DATED 02/28/2013 AND MODIFIED BASED ON FIELD ASSESSMENT BY VHB.
2. CHANNEL ELEVATION BASED ON CONTOURS SHOWN ON EPSC PLAN PROVIDED BY CHA, INC. DATED 02/28/2013 AND NOT ASSESSED IN THE FIELD BY VHB.

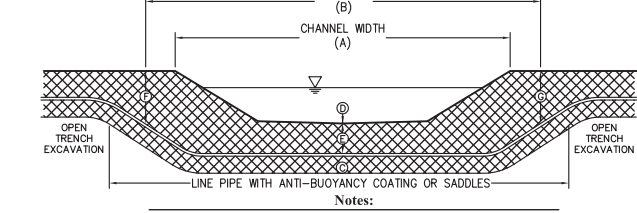

8 Open Trench Stream Crossing - Typical Section 04/13
N.T.S. Source: VHB

- Notes:
- THIS CONFIGURATION IS FOR OPEN TRENCH EXCAVATION OF STREAM CROSSINGS AS SHOWN ON PROJECT PLANS. SEE ALIGNMENT SHEETS FOR LOCATIONS OF THIS CONFIGURATION.
 - TOP OF PIPELINE MUST BE AT LEAST AS DEEP AS THE CHANNEL BOTTOM (DIMENSION D) THROUGHOUT THE FLUVIAL EROSION HAZARD (FEH) CORRIDOR.
 - FIELD CONDITIONS WITH HIGH LOADING AND/OR HIGH SURVIVABILITY REQUIREMENTS MAY WARRANT THE USE OF A TRM WITH A TENSILE STRENGTH OF 44 kN/m(3,000 lb/ft) OR GREATER.
 - ELEVATIONS PROVIDED ARE BASED ON APPROXIMATE NAVD 88 DATUM AND MUST BE FIELD VERIFIED PRIOR TO INSTALLATION OF PIPELINE.
 - FEH CORRIDOR IS LISTED AS NOT APPLICABLE (N/A) WHERE THE STREAM CROSSES OR IS ADJACENT TO AN EXISTING ROADWAY OR OTHER INFRASTRUCTURE THAT RESULTS IN RIVER MANAGEMENT CONSTRAINTS AT THAT LOCATION. FEH CORRIDOR WIDTHS AT THESE LOCATIONS ARE SHOWN FOR INFORMATION PURPOSES ONLY.
 - RESTORE DISTURBED CHANNEL, STREAM BANKS, AND APPROACHES FOLLOWING PIPELINE INSTALLATION PER EPSC PLAN.

DWG. NO.	REFERENCE DWG.	REV	DSN	CK	DESCRIPTION	INITIALS	DATE	INITIALS	DATE	YEAR: 2015	W.O.	SCALE: NOTED	DWG. ANGP-T-G-017	REV. 2
		2	BCK	TDB	VHB EDITS (12/10/15)									
		1	BCK	TDB	VHB EDITS (6/09/15)									

VHB Vanasse Hangen Brustlin, Inc.

CHIA

38 Eastwood Drive, Suite 105
South Burlington, VT 05403
Main: (802) 735-0372 • www.chiacompanies.com

Vermont Gas

VERMONT GAS
PROPOSED 12" PIPELINE
ADDISON NATURAL GAS PROJECT
CONSTRUCTION DETAILS

LOC. CHITTENDEN & ADDISON COUNTIES

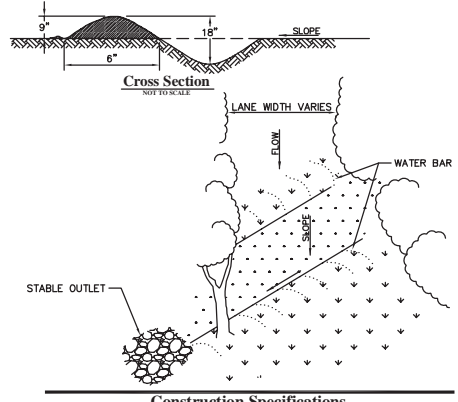

Construction Specifications

- INSTALL THE WATER BAR AS SOON AS THE RIGHT OF WAY IS CLEARED AND GRADED.
- DISK OR STRIP THE SOIL FROM THE BASE FOR THE CONSTRUCTED RIDGE BEFORE PLACING FILL.
- TRACK THE RIDGE TO COMPACT IT TO THE DESIGN CROSS SECTION.
- THE OUTLET SHALL BE LOCATED ON AN UNDISTURBED AREA. FIELD SPACING WILL BE ADJUSTED TO USE THE MOST STABLE OUTLET AREAS. OUTLET PROTECTION WILL BE PROVIDED WHEN NATURAL AREAS ARE NOT ADEQUATE.
- FOR PERMANENT WATER BARS, VEHICLE CROSSING SHALL BE STABILIZED WITH GRAVEL. EXPOSED AREAS SHALL BE SEDED AND MULCHED. FOR TEMPORARY WATER BARS, VEHICLE CROSSING SHALL BE COMPACTED AND MAINTAINED PER THESE SPECIFICATIONS. FOLLOWING THEIR USE, WATER BARS SHALL BE REGRADED TO MATCH PRE-CONSTRUCTION CONDITIONS. TOPSOIL SHALL BE RE-APPLIED THEN ALL AREAS OF EXPOSED SOIL SHALL BE FULLY STABILIZED PER THE EPSC PLAN.
- INSPECT WATER BARS FOR EROSION DAMAGE AND SEDIMENT. CHECK OUTLET AREAS AND MAKE REPAIRS AS NEEDED TO RESTORE OPERATION.
- SPACING:

SLOPE (%)	SPACING (FT)
<5	125
5-10	100
10-20	75
20-35	50
>35	25

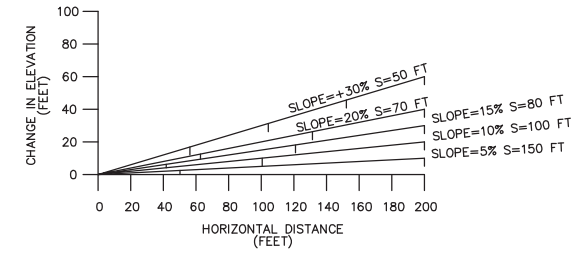

NOTE: S = TRENCH BREAKER SPACING

NOTES:

- PERMANENT TRENCH BREAKER SANDBAGS SHALL NOT BE FILLED WITH TOPSOIL.
- SPACINGS SHOWN ARE RECOMMENDED MINIMUM GUIDELINES. OSPC REPRESENTATIVE MAY ADJUST SPACING IN THE FIELD WITH PRIOR WRITTEN APPROVAL OF OWNER.
- ONE TRENCH BREAKER IS REQUIRED AT ALL STREAM BANKS AND AT WETLAND BOUNDARIES.

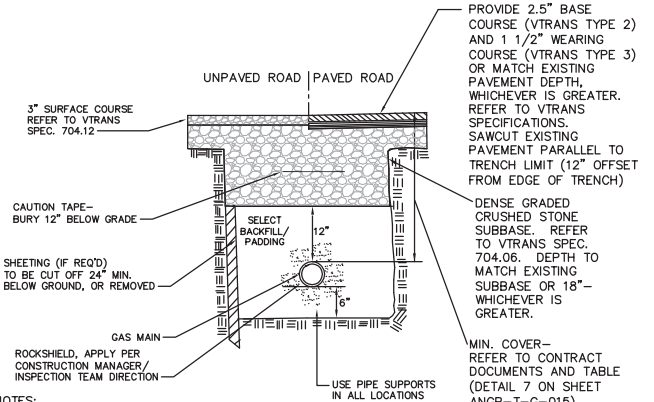

NOTES:

- UNLESS OTHERWISE NOTED OR DIRECTED, SELECT BACKFILL MATERIAL SHALL CONSIST OF NATIVE MATERIAL CONTAINING STONES NO LARGER THAN 1.5" IN THE LONGEST DIMENSION. A SHAKER BUCKET OR SCREEN MAY BE USED IF NATIVE MATERIAL IS TOO LARGE. SAND MAY BE REQUIRED FOR SELECT BACKFILL IF DIRECTED BY CONSTRUCTION MANAGER/INSPECTION TEAM.
- IN AREAS OF ROCK OR UNSUITABLE SOILS OR AS DETERMINED BY CONSTRUCTION MANAGER, PIPE SHALL BE BEDDED WITH COMPACTED SELECT BACKFILL. WHEN NATIVE MATERIALS ARE UNSUITABLE FOR BACKFILLING, AS DIRECTED BY CONSTRUCTION MANAGER, CONTRACTOR SHALL BACKFILL WITH COMPACTED SAND TO 12" ABOVE TOP OF PIPE. THE REMAINING TRENCH SHALL BE BACKFILLED WITH AN APPROVED MATERIAL.
- IN RESOURCE AREAS (E.G. WETLANDS AND PAS AREAS) GENERAL BACKFILL SHALL BE NATIVE MATERIAL TO MATCH PROFILE DEPTH OF ADJACENT NATIVE, UNDISTURBED SUBSOIL/SURFACE SOIL INTERFACE. EXCESS SUBSOIL TO BE PROPERLY DISPOSED OF AND STABILIZED.
- THE OWNER SHALL PROVIDE TESTING SERVICES TO INSURE THAT THE IN-PLACE DENSITY OF THE BACKFILL MEETS REQUIREMENTS DETERMINED IN THE SPECIFICATIONS.
- ALL TRENCH CONSTRUCTION SHALL CONFORM TO APPLICABLE FEDERAL, STATE AND LOCAL REGULATIONS.
- CONTRACTOR SHALL ENSURE BACKFILL IS PLACED/COMPACTED IN 12" (MAX) LIFTS ABOVE THE PIPE.
- PROVIDE SUPPORTS IN ALL LOCATIONS (PIPE PILLO, STACKED SAND BAGS, OR OWNER APPROVED EQUAL). SUPPORTS SHALL BE SECURE AND STABLE AND ADEQUATE TO SUPPORT PIPE DURING LOWERING AND BACKFILL OPERATIONS.

CHA PLAN SHEET #	TOWN	PROJECT COMPONENT	PLANT ID CODE	STATE RANK	MATTING LOCATIONS (STATION)
ANGP-EPSC-014	WILLISTON	TRANSMISSION (ACCESS ROAD)	2012-RTE-CT-03-1	S2/S3	366+50 TO 368+75 AND ON ACCESS ROAD
ANGP-EPSC-022	WILLISTON	TRANSMISSION	2012-RTE-CT-08-4	S2/S3	562+50 TO 563+75
ANGP-EPSC-039	HINESBURG	TRANSMISSION	2012-RTE-CT-08-0	S2/S3	992+80 TO 993+50
ANGP-EPSC-039	HINESBURG	TRANSMISSION	2012-RTE-CT-08-2	S2/S3	1001+20 TO 1002+20
ANGP-EPSC-039	HINESBURG	TRANSMISSION	2012-RTE-CT-08-2	S2/S3	1003+50 TO 1005+80
ANGP-EPSC-040	HINESBURG	TRANSMISSION	2012-RTE-CT-04-1	S2/S3	1021+20 TO 1023+00
ANGP-EPSC-051	MONKTON	TRANSMISSION	2012-RTE-ACT-0-83	S2/S3	1302+10 TO 1307+90
ANGP-EPSC-066	NEW HAVEN	TRANSMISSION	2012-RTE-CT-05-1	S2/S3	1649+50 TO 1652+00
ANGP-EPSC-066	NEW HAVEN	TRANSMISSION	2012-RTE-CT-06-1	S2/S3	1665+50
ANGP-EPSC-066	NEW HAVEN	TRANSMISSION	2012-RTE-AT-05-3	S1	1659+60
ANGP-EPSC-066	NEW HAVEN	TRANSMISSION	2012-RTE-LV-05-4	S2	1659+60
ANGP-EPSC-066	NEW HAVEN	TRANSMISSION	2012-RTE-AT-06-3	S1	1669+70 TO 1670+50
ANGP-EPSC-075, 079, 077	NEW HAVEN	TRANSMISSION	2012-RTE-CT-06-9	S2/S3	1918+00 TO 1966+50
ANGP-EPSC-V011	FERRISBURGH	DISTRIBUTION MAIN	2012-RTE-CT-06-8	S2/S3	118+80 TO 119+10

Notes:

- INSTALL CONSTRUCTION MATS ON STATION LOCATIONS LISTED IN TABLE TO PROTECT RARE PLANT SPECIES.
- LIMIT DURATION OF MATTING DURING GROWING SEASON TO EXTENT PRACTICABLE.
- REMOVE MATTING IMMEDIATELY FOLLOWING THEIR USE. FOR EXAMPLE, WHERE MATTING IS USED FOR TEMPORARY STOCKPILING OF SOIL FROM TRENCHING OPERATIONS, REMOVE MATTING IMMEDIATELY FOLLOWING BACKFILL OPERATIONS.
- AT A MINIMUM, MATTING IS NOT TO BE LEFT IN PLACE FOR MORE THAN 28 DAYS WHERE FEASIBLE.
- REFER TO ADDITIONAL ENVIRONMENTAL NOTE 12 ON SHEET ANGP-T-G-011

1 Water Bars

N.T.S. Source: Vermont Standards and Specs for EPSC 2006 LD_

2 Permanent Trench Break Spacing Guideline

N.T.S. Source: CHA LD_

3 Typical Trench Detail-Roadways and Driveways

N.T.S. Source: CHA LD_

4 RTE Matting Table

N.T.S. Source: VHB 09/13

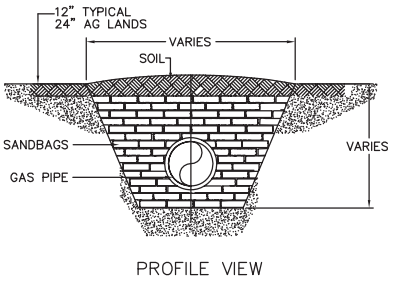

PROFILE VIEW

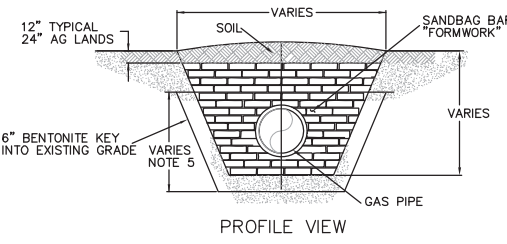

PROFILE VIEW

NOTES:

- PERMANENT TRENCH BREAKER WITH BENTONITE SEAL IS INTENDED TO PROHIBIT WATER FLOW THROUGH THE BREAKER.
- PERMANENT TRENCH BREAKER WITH BENTONITE SEAL TO BE INSTALLED AT EDGE OF WETLANDS AND STREAMS.
- SAND BAG BARRIER WIDTH SHALL BE MINIMUM 1 BAG WIDE AND/OR AS FIELD DETERMINED TO PROVIDE STABILITY.
- BENTONITE IS TO BE INSTALLED IN THE VOID SPACE BETWEEN THE SANDBAG BARRIER "FORMWORK" IN SUCH A MANNER TO COMPLETELY SURROUND THE PIPE AND FILL THE VOID FROM THE BOTTOM OF THE TRENCH TO A HEIGHT 6" ABOVE THE LEVEL OF IMPORTED PADDING MATERIAL WHICH IS INSTALLED ON THE EXTERIOR SIDE OF THE SANDBAG BARRIER IN THE WETLAND ZONE.
- AFTER BENTONITE PLACEMENT, INSTALL SAND BAGS ON TOP OF THE PERMANENT TRENCH BREAKER AND BENTONITE SEAL TO THE REQUIRED HEIGHT PER DETAIL 2 AND BACKFILL EXTERIOR SIDES OF SAND BAG BARRIERS.

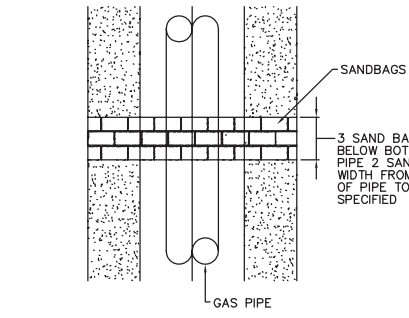

PLAN VIEW
SAND BAG TRENCH BREAKER

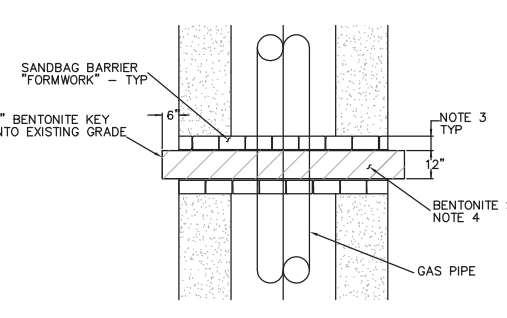

PLAN VIEW
TRENCH BREAKER WITH BENTONITE

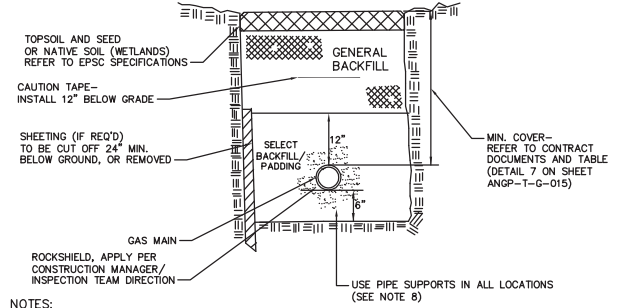

NOTES:

- UNLESS OTHERWISE NOTED OR DIRECTED, SELECT BACKFILL MATERIAL SHALL CONSIST OF NATIVE MATERIAL CONTAINING STONES NO LARGER THAN 1.5" IN THE LONGEST DIMENSION. A SHAKER BUCKET OR SCREEN MAY BE USED IF NATIVE MATERIAL IS TOO LARGE. SAND MAY BE REQUIRED FOR SELECT BACKFILL IF DIRECTED BY CONSTRUCTION MANAGER/INSPECTION TEAM.
- UNLESS OTHERWISE NOTED OR DIRECTED, GENERAL BACKFILL MATERIAL SHALL CONSIST OF NATIVE MATERIAL CONTAINING NO STONES OR CLOSS LARGER THAN 2" IN THE LONGEST DIMENSION.
- IN AREAS OF ROCK OR UNSUITABLE SOILS OR AS DETERMINED BY CONSTRUCTION MANAGER, PIPE SHALL BE BEDDED WITH COMPACTED SELECT BACKFILL. WHEN NATIVE MATERIALS ARE UNSUITABLE FOR BACKFILLING, AS DIRECTED BY CONSTRUCTION MANAGER, CONTRACTOR SHALL BACKFILL WITH COMPACTED SAND TO 12" ABOVE TOP OF PIPE. THE REMAINING TRENCH SHALL BE BACKFILLED WITH AN APPROVED MATERIAL.
- IN RESOURCE AREAS (E.G. WETLANDS AND PAS AREAS) GENERAL BACKFILL SHALL BE NATIVE MATERIAL TO MATCH PROFILE DEPTH OF ADJACENT NATIVE, UNDISTURBED SUBSOIL/SURFACE SOIL INTERFACE. EXCESS SUBSOIL TO BE PROPERLY DISPOSED OF AND STABILIZED.
- THE OWNER SHALL PROVIDE TESTING SERVICES TO INSURE THAT THE IN-PLACE DENSITY OF THE BACKFILL MEETS REQUIREMENTS DETERMINED IN THE SPECIFICATIONS.
- ALL TRENCH CONSTRUCTION SHALL CONFORM TO APPLICABLE FEDERAL, STATE AND LOCAL REGULATIONS.
- CONTRACTOR SHALL ENSURE BACKFILL IS PLACED/COMPACTED IN 12" (MAX) LIFTS ABOVE THE PIPE.
- PROVIDE SUPPORTS IN ALL LOCATIONS (PIPE PILLO, STACKED SAND BAGS, OR OWNER APPROVED EQUAL). SUPPORTS SHALL BE SECURE AND STABLE AND ADEQUATE TO SUPPORT PIPE DURING LOWERING AND BACKFILL OPERATIONS.

5 Permanent Trench Break or Sandbags

N.T.S. Source: CHA LD_

6 Typical Trench Detail-Cross Country

N.T.S. Source: CHA LD_

7 Typical Minimum Cover of Pipeline

N.T.S. Source: CHA LD_

AREA	COVER
VELCO ROW OR ROW ACCESS POINT	4'
VTRANS ROW*	4'
AG AREAS*	4'
PAVED AREAS	5'
BOTTOM OF DITCHLINE	4'
STREAMS	5' MIN. UNLESS OTHERWISE NOTED ON SHEET ANGP-T-G-017
ALL OTHER AREAS*	3'

*UNLESS OTHERWISE NOTED ON APPROVED PERMIT PLANS OR CONSTRUCTION LINE LIST

DWG. NO.	REFERENCE DWG.	REV	DSN	TDB	CK	DESCRIPTION	INITIALS	DATE	INITIALS	DATE	YEAR:	W.O.	SCALE:	DWG.	REV.
		1	BCK	TDB		DEPTH OF COVER UPDATE (6/11/15)					2015		NOTED	ANGP-T-G-015	1

	BID	CONSTRUCTION
ENVIRONMENTAL	JLS 06/28/13	JLS 04/02/15
DRAFTING DESIGNER	GIL 06/28/13	GIL 04/02/15
DRAFTING SUPERVISOR	BZD 06/28/13	BCK 04/02/15
DESIGN ENGINEER	MDF 06/28/13	TDB 04/02/15
DESIGN MANAGER	SAB 06/28/13	JEO 04/02/15

VERMONT GAS
PROPOSED 12" PIPELINE
ADDISON NATURAL GAS PROJECT
CONSTRUCTION DETAILS
LOC. CHITTENDEN & ADDISON COUNTIES

Vermont Gas logo and VHB Vanasse Hangen Brustlin, Inc. logo. Address: 38 Eastwood Drive, Suite 105, South Burlington, VT 05403. Phone: (802) 795-0372. Website: www.chacompanies.com